

***Superlux***<sup>®</sup>

## Dear Friends and Partners,

Starting from a bachelor apartment just 30 years ago, the Superlux company is now a modern manufacturer occupying a 8.65-acre (350 Ares) site in the heart of Shanghai city. We do not stop there. We are currently building a brand new 57.66-acre (2333 Ares) facility in the Superlux industrial zone at Lan-Yuan port, China. This growth would not have been possible without the strong commitment throughout the years of you, our friends and partners. We cherish every opportunity when we can work together to bring the greatest products to the users. Value in Sound is our core belief, continually motivating us to go forward. Our best reward is to hear you say, "Wow, Superlux products are a really great value!" Then all our efforts have been worthwhile.

We insist on doing the right thing and doing it right from start to finish. We focus on electronic audio products, R&D and production. From the input to the output, from the microphones, amplifiers and headphones to the speakers, we have a very complete product line. Our strengths are a high production rate, a global hub logistics center and an ERP internal control system. Our management team integrates R&D, production, marketing and sales so we can always provide a total solution for our customers.

An important part of our R & D is Mr Pan Zheng Yuan who was invited to join the Superlux team in 1996. Mr. Pan is from a pioneering microphone family who successfully developed the first condenser microphone in China 60 years ago. Following in his father's footsteps, Mr. Pan has worked on developing electroacoustic products for 48 years and is a master technician who is truly passionate about his art. His expertise has proved invaluable and he is truly an inspiration to everybody in the R & D team at Superlux.

Superlux is a company who thinks highly of our employees' training and benefits. Through daily exercise, we motivate our people and grow together to create a strong team, one of the best in the industry. We have a very long vision for the electronic audio industry, and hope to create even more value for you, our friends and partners.

Your friend,

President *David Liu.*



## Locations of Superlux

### International Sales & Marketing Office

#### GOANG-FANN CO., LTD

3F., No. 7, Aly. 2, Ln. 342, Fude 1st Rd., Xizhi Dist.,  
New Taipei City 22150, Taiwan (R.O.C.)

Post Code: 22150

TEL: +886-2-2693-1323

FAX: +886-2-2694-8990

Email: sales@superlux.com.tw

### China Sales & Marketing Office

#### SUPERLUX ENTERPRISE DEVELOPMENT (SHANGHAI) CO., LTD.

3F, No.96, Lane 3938, Huqingping Road, QingPu  
District, Shanghai, China

Post Code: 201703

TEL: +86-21-6922-3766

Email: sales@superlux.com.tw

#### SUPERLUX ENTERPRISE DEVELOPMENT (LIANYUNGANG) CO.,LTD.

No.5, Ningbo South Road, Economic Development  
Zone, Guan'nan County, Lianyungang City, China

Post Code: 222000

Email: sales@superlux.com.tw

#### WEIHAO INDUSTRIAL CO.,LTD

No.7 Qingxi Binhe West Road, Qingxi Town,  
Dongguan City, Guangdong Province, China

Post Code: 523600

Email: willie@w-h.com.cn

For more information, please visit  
[www.superlux.com.tw](http://www.superlux.com.tw)



# Contents

## Recording, Broadcast, USB Microphone

### • Recording Microphones

CMH8AMKII	3
CMH8D	4
CMH8G	4
CMH8A	5
CMH8B	5
CMH8C	5
CMH8AH	6
CMH8BH	6
CMH8CH	6
L211	7
PRO238MKII	7
S125	8
E524D	8
S241	9
S502	10
S502MKII	10
CMH8K	11
E205	11

### • Broadcast Microphones

R102	12
R102MKII	12
D421	13
CMH8E	13
E523D	14
PRA318	14
CM9HL	15
WSK1	15
PRA118	16
PRA116B	16
E525	17

### • USB Microphones

E431U	18
L401U	18
E205U	19
E205UMKII	19

## Vocal, Headworn, Lavalier Microphones

### • Vocal Microphones

D108MKII	22
TM58	23
PRO238MKII	24
S125	24
PRO238C	25
TOP248	25
TOP258	26
PRO248	26

PRO258	27
WH5	28
D107	29
D108	29
D109	30
D103	30
FH12	31
FI10	31
PRAC	32
PRAD	32
ECO88S	33
ECOA1	33

### • Headworn Microphones

PRA20	34
PRA30	34
E10A	35
E10B	35

### • Lavalier Microphones

E12A	36
WO518	37
WU518	37

## Instrument Microphones & Drum Sets

### • Instrument Microphones

PRA383	40
E101	41
D112	41
PRO218A	42
PRO228A	42
PRO268B	43
PRA288A	43
D10B	44
E124D	44
E100	45
E102	45
HO8	46
FK2	47
FT4	47
FS6	47
HI10	48
E109	48
PRA628MKII	49
PRA638	49
PRA218A	50
PRA218B	50
PRA228A	51
PRA268A	51

### • Drum Sets

DRK681	52
DRKB5C2MKII	52
DRKF5H3	53
DRKK5C2	53
DRKA3	54
DRKA3C2	54
DRKA5	55
DRKA5C2	55

### Value Packs

MSKA	58
MSK10B	59
MSK124	59

### Installation

#### • Gooseneck Microphone

E326PRO	62
E321	62
E322	63
PRA518	63
PRA528	64
PRA618	64
D302	65
E306	65
PRA538	66
E309DPRO	66
E361	67
PRA528DS	67

#### • Gooseneck Microphone Optional Accessories

HM22	68
HM23	68
HM24	68
HM24C	68
GT2B	68
GT6F	68
GM13D	68
GM13G	68
PS518	68
DS002	68
DS003	68

#### • Installation

E303	69
E304	69
PRA418	70
PRA428	70
E323	71
E324	71
E308	72

PRA52	72
D401S	73
PRA535	73
PRA535NC	74
PRA448	74

## Conference System & Measurement

### • Conference System Inter- com Series

IS103	76
IS103A	76
BP101	77
HMD685a	77

### • Measurement Microphone

ECM999	78
ECM888B	78
E302	79
PINK STICK	79
ECM999U	80

## Wireless Systems

UK82	82
UK3	82
VT9	83

## Microphone Accessories

### • Preamplifiers, Phantom Power Supplies

PS418D	86
PS418S	86
PS2A	86
PS2B	86
CP818	87
CP828	87
CP838	87

### • Pop Filters

HM20	87
HM43	87
HM18AG	87
MA91	87

### • General Microphone Clips

HM8	88
HM9	88
HM10	88
HM16	88
HM29	88
HM37	88
HM38	88

HM39	88	• Windscreens		HMC660PRO	117	<b>Electronics</b>	
HM42	88	S02	92	HMD660PRO	117	HA3D	140
HM101A	88	S04	92	HMC660	118	HA40	140
YA1	88	S05F	92	HMD660	118	HA4D	141
YA2	88	S07F	92	HMD685	119	HA1D	141
YA3	88	S08F	92	HMD685a	119	FMX22D	142
• Camera Microphone Mount Adapters		S09	92	HMD685aMKII	120		
YA10	88	S09F	92	HMC681EVO	120		
HM35C	88	S11	92	HMC631	121	<b>Personal Audio</b>	
HM40C	88	S13F	92	A/HD381	122	• Headphones	
• Shock Mount		S25	92	B/HD681	122	HD671	144
HM56	89	S40	92	C/HD662	122	HD330PRO	144
HM56B	89	S65	92			HD351	145
HM60	89	S14	92	<b>Portable PA Systems &amp; Speakers</b>		HD685	145
HM61	89	S15	92	• SP Series		HD651	146
HM57	89			SP108	124	HD381	147
HM57E	89	<b>Headphones &amp; Headsets</b>		SP110	124	HD440	148
HM7	89	HD660PRO	94	• SFD Series			
HM26A	89	HD330PRO	94	SF8D	126	• Microphones	
HM26B	89	HD668BMKII	95	SF10D	126	D421	149
HM26C	89	HD687	96	SF12D	127	WO518	149
HM31	89	HD688	96	SF15D	127	D108MKII	150
HM30	89	HD671	97	SF12DS	128	E431U	151
HM33	89	HD672	97	SF15DS	128	L401U	151
HM35	89	HD662EVO	98	SF18DS	129	E205U	152
HM35	89	HD681EVO	98			E205UMKII	152
HM32	89	HD681AIR	99	• SF Series		E531B	153
HM40	90	HD669	100	SF118AS	130	E532B	153
HM54	90	HD668B	101	SF110A	131	E522B	154
C2	90	HD661	102	SF112A	131	D106	154
HM15	90	HD662	103	SF115A	131	D10A	155
MA90	90	HD681	104	SF12AS	132	EM210	155
• Drum Clamps		HD572	105	SF15AS	132	E105	156
DMC01	91	HD572A	106	SF10A	133	E108	157
DMC02	91	HD660	107	SF12A	133		
DMC03	91	HD330	107	SF15A	133	<b>Portable mini-PAs</b>	
HM12A	91	HD667	108	SF8	134	MA818	160
HM12E	91	HD665	109	SF8A	134	MA500	161
HM12F	91	HD631	109				
HM12C	91	HD562	110	• Portable Speakers			
HM12D	91	HD685	110	SE108	135	<b>Cables, Stands, Mounts and Racks</b>	
HM12G	91	HD581	111	SE108W	135	• Cables	
HM25	91	HD440	111			CFM Balanced Signal Cable	164
HM12C	91	HD651	112	• SK Series		CFI Instrument Signal Cable	164
HM12CA	91	HD387	113	SK110	136	SFI Instrument Signal Cable	165
HM12CB	91	HD387i	113	SK112	136	SFS Speaker Cable	165
HM12D	91	HD361	114	• BES Series		SFM Balanced Signal Cable	165
HM12DA	91	Y-SPLIT	114	BES3.5	137		
HM12DB	91	HD351	115	BES5	137	• Microphone Stands	
HM12DC	91	HD386	115	BES5A	138	MS131E/BAG	166
HM12DD	91	HD381	116			MS108E/BAG	166

MS152E/BAG	166	HM6	170
MS153E/BAG	166	DS01	170
MS158E/BAG	167	DS011	170
<b>• Microphone Stands (Without Extension Legs)</b>		D1	170
MS432	167	<b>• Speaker Stands</b>	
MS101/BAG	167	LS718S	171
MS110	168	SPA01	171
MS107	168	SPS410A	171
MS108AB	168	SPS410B	171
MS128/BAG	168	SPSK1	171
MS177	168	SPSK2	171
MS188	168	SPE202	172
MS200	168	SPE428	172
MS300	168	SPS410AB	172
<b>• Instrument Stands, Music Stands, Guitar Stands</b>		SPS400	172
MS104/BAG	169	SPS430L	172
MS105/BAG	169	<b>• Speaker Stands &amp; Mounts</b>	
MUS211	169	SPS838	173
MUS298	169	SPS867A	173
GS518	169	SPS869	173
GS528	169	SPS878	173
<b>• Table Stands</b>		SPS813	173
HM66	170	SPS823	173
HM90	170	MA08	173
HM48B	170	MA09	173
HM58B	170	<b>• Racks</b>	
HM502	170	RS908	174
HM503	170	RS912	174
MTS004	170	RS916	174
MTS014	170	RS921	174
MTS024	170	DS70	174

**• Grille Nets, Adapters and Gooseneck LED Lights**

YA18	175
YA28	175
YA38	175
FO58	175
L01U	175
L02X	175

# Appendix

<b>Which Microphone for You?</b>	177
<b>Stereo Recording Techniques</b>	178
<b>Product Index</b>	179



**Recording  
Broadcast  
USB Microphone**

***Superlux***<sup>®</sup>





# CMH8AMKII

## Large Diaphragm True Condenser Microphone Set

**Studio / Broadcast / Vocals / Woods / Strings / Acoustic Guitar / Piano / Brass / Percussion / Eastern & Western Instruments**

Warm and Natural Recording Experience, Crafted by Superlux!

The CMH8AMKII is a studio-grade large diaphragm condenser microphone, featuring a 1-inch diameter, 3 $\mu$ m thickness gold-plated diaphragm. It captures delicate sound details, especially excelling in low and mid-frequency performance, resulting in a warm and rich tone that is particularly suitable for recording vocals, singing, and instruments. This microphone's preamp circuit has been optimized to significantly reduce self noise, ensuring clearer and purer recordings. Even when faced with very quiet or faint sound sources, it delivers clean and interference-free recording results.

The CMH8AMKII has a wide pickup range, allowing for a natural soundstage, making it especially suitable for recording sources that require a sense of space. It not only excels in vocal recordings but is also well-suited for capturing guitars, drums, pianos, and other instruments, widely used in professional studios. Its excellent dynamic range enables this large diaphragm microphone to authentically present the depth and dimension of sound, adding layers and richness to recorded music or audio materials.

- **Superior Sound Quality:** 1-inch 3 $\mu$ m gold-plated diaphragm, accurately captures sound details, providing rich low and mid frequencies, ideal for vocals and instrument recording
- **Low Noise Design:** Optimized preamp circuit significantly reduces background noise, ensuring clear, interference-free recordings
- **Natural Soundstage:** Wide pickup range, delivering a natural soundstage suitable for various sources
- **Excellent Dynamic Range:** Effectively presents sound depth and dimension, enhancing the layers in recordings

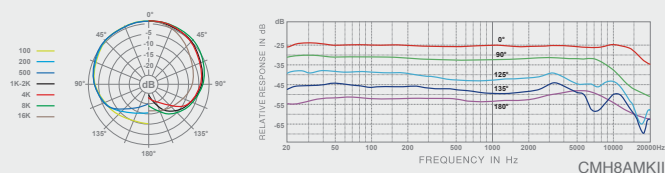

HM7 Elastic Shock Mount

### Specifications



Type	True condenser, $\varnothing$ 1" ( $\varnothing$ 25.4 mm)
Polar Pattern	Cardioid
Frequency Response	30-20,000 Hz
Sensitivity	-30 dBV/Pa (31.2 mV)
Rated impedance	200 $\Omega$
Minimum load impedance	1,000 $\Omega$
S/N Ratio	89 dB
Equivalent Noise	5 dB A-Weighted
Max. SPL	138 dB
Dynamic Range	133 dB
Power supply	48 V DC 2.7 mA
Finish	Black / Silver
Connector	XLR3M
Dimensions	$\varnothing$ 54 x 200 mm ( $\varnothing$ 2.13" x 7.87")
Net Weight	550 g (19.4 oz)
Accessories Furnished	HM7 Elastic Shock Mount, 5M Straight Cable, Microphone Pop Filter, Carrying Pouch
Packaging	Colorful outer packaging

# Recording Microphones

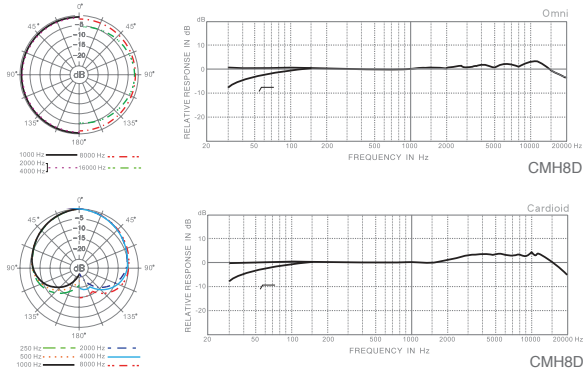

## CMH8D CMH8G

Vacuum Tube Condenser, Large Diaphragm

Studio / Classical Recording / Vocal / String / Acoustic Guitar / Piano / Brass / Woods / Percussion / Western and Eastern Instrument

This dual 1" large diaphragm, true condenser, low noise microphone is a valve amplifier design which provides exceptionally warm sound and accurate sound textures, making it ideal for creative audio applications. A Superlux valve microphone is the best choice for those who want that true tube sound.

- 1" gold-evaporated dual diaphragm
- Aluminum carrying case
- Champagne silver finish
- Specific power supply
- Valve amplifier design for true natural tube sound

CMH8D:  
Dual diaphragm and switches between omni and cardioid directivity

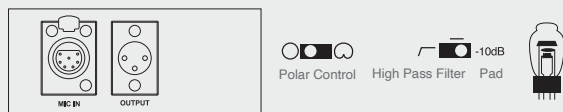

PS1 Power Supply for CMH8D

CMH8G:  
Dual diaphragm structure with remote 9 directivity variations

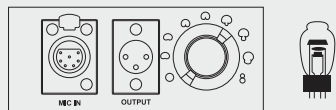

PS3 Power Supply for CMH8G



### Specifications

Model No.	CMH8D	CMH8G
Type	Vacuum tube true condenser, Ø1" (Ø25.4 mm) dual diaphragm	Vacuum tube true condenser, Ø1" (Ø25.4 mm) dual diaphragm
Polar Pattern	Omni / Cardioid	9 directivity variations from omni-cardioid-figure 8
Frequency Response	30-20,000 Hz	30-20,000 Hz
Low Frequency Filter	100 Hz	N/A
Pad	-10 dB	N/A
Sensitivity	Omni: -32 dBV/Pa (25 mV) Cardioid: -28 dBV/Pa (40 mV)	Omni: -32 dBV/Pa (25 mV) Cardioid: -28 dBV/Pa (40 mV) Figure 8: -32 dBV/Pa (25 mV)
Output Impedance	200 Ω	200 Ω
Min. Load Impedance	1,000 Ω	1,000 Ω
S/N Ratio	76 / 80 dB	76 / 80 / 76 dB
Equivalent Output Noise	18 / 14 dB	18 / 14 / 18 dB
Max. SPL	146 / 142 dB SPL	146 / 142 / 146 dB SPL
Dynamic Range	128 dB	128 dB
Finish	Champagne silver	Champagne silver
Connector	XLR7M	XLR7M
Dimensions	Ø54x200 mm (Ø2.13"x7.87")	Ø54x200 mm (Ø2.13"x7.87")
Net Weight	560 g (19.7 oz)	550 g (19.4 oz)
Accessories Furnished	PS1 phantom power supply HM8 adapter, YA2 threaded adapter, S65 windscreens, HM7C shock mount, power cable, specific 7-meter cable from microphone to power	PS3 phantom power supply
Optional Accessories	HM48B, HM58B table arm, HM18AG pop filter, MS158/BAG big mic stand	
Packaging	A3 aluminum carrying case colorful outer packaging	A3 aluminum carrying case colorful outer packaging

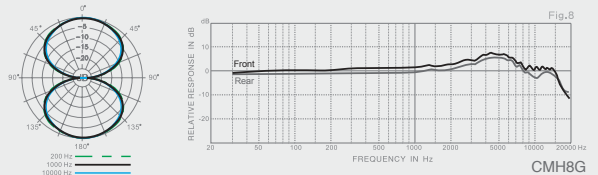
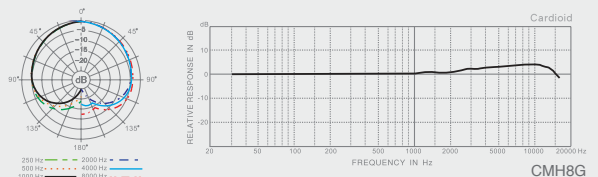
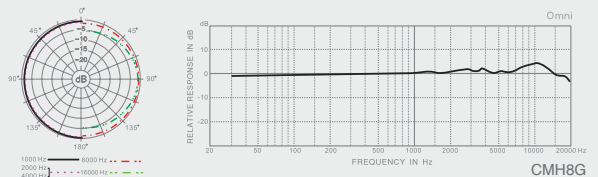

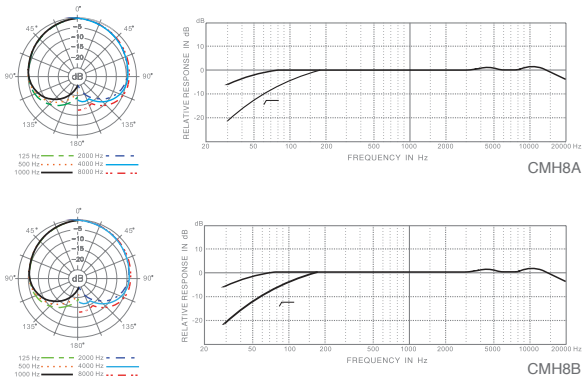

# CMH8A CMH8B CMH8C

Large Diaphragm, Variable Directivity, Flat Response

Studio / Broadcast / Vocals / Woods / Strings / Acoustic Guitar / Piano / Brass / Percussion / Eastern & Western Instruments

These all purpose studio-grade condenser microphones combine skillful workmanship with a 1-inch gold deposited diaphragm for the most vivid sound. There are a variety of optional accessories available to meet the requirements of almost all applications and settings.

## CMH8A

The CMH8A has a single diaphragm with fixed cardioid polar pattern. There is no external control switch, but there is an internal low cut filter. The CMH8A has the same sound quality as the CMH8B, making it the right choice for those on a limited budget.

## CMH8B

The CMH8B has a single diaphragm with fixed cardioid polar pattern. This mic also has a built-in HPF to reduce unwanted lower frequency sounds such as footsteps and air-handler noises and a -10dB pad switch for high SPL instrument. The CMH8B is the middle priced unit for who do not need multi-directivity.

## CMH8C

The CMH8C is the full-featured version, having a dual diaphragm for 3 switchable polar patterns. A built-in HPF reduces those unwanted low frequency rumbles while the -10dB pad switch effectively reduces high SPL for better sound pick up. The CMH8C is a great recording microphone with extended frequency response, low distortion, low noise and high dynamic range, and will meet the critical demands of the best professional sound engineers.

- 1" Gold-coated diaphragm
- Champagne silver finish
- A3 protective plastic carrying case
- Transformer output

CMH8A: Cardioid, internal low cut

CMH8B: Cardioid, external -10 dB pad and low cut switch

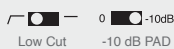

CMH8C: Figure 8, Cardioid, Omni, external -10 dB pad and low cut switch



SMKH8A stereo kit, matched pair of CMH8A

SMKH8B stereo kit, matched pair of CMH8B

SMKH8C stereo kit, matched pair of CMH8C



## Specifications

Model No.	CMH8A	CMH8B	CMH8C
Type	True condenser, Ø1" (Ø25.4 mm)	True condenser, Ø1" (Ø25.4 mm)	True condenser, Ø1" (Ø25.4 mm), dual diaphragm
Polar Pattern	Cardioid	Cardioid	Variable polar pattern from figure 8, cardioid and omni
Frequency Response	30-20,000 Hz	30-20,000 Hz	30-20,000 Hz
Low Frequency Filter	100 Hz, (internal)	100 Hz	100 Hz
Pad	N/A	-10 dB	-10 dB
Sensitivity	-34 dBV/Pa (20 mV)	-34 dBV/Pa (20 mV)	-35 / -30 / -35 dBV/Pa (17/ 28/ 17mV)
Output Impedance	200 Ω	200 Ω	200 Ω
Min. Load Impedance	1,000 Ω	1,000 Ω	1,000 Ω
S/N Ratio	76dB	76dB	76 / 80 / 76dB
Equivalent Output Noise	18 dB	18 dB	18 / 14 / 18 dB
Max. SPL	132 dB SPL	142 dB SPL	142 / 138 / 142 dB SPL
Dynamic Range	114 dB	124 dB	124 dB
Power Requirements	48V DC, 2.7 mA	48V DC, 2.7 mA	48V DC, 4 mA
Finish	Champagne silver	Champagne silver	Champagne silver
Connector	XLR3M	XLR3M	XLR3M
Dimensions	Ø54 x 200 mm (Ø2.13" x 7.87")	Ø54 x 200 mm (Ø2.13" x 7.87")	Ø54 x 200 mm (Ø2.13" x 7.87")
Net Weight	550 g (19.4 oz)	550 g (19.4 oz)	565 g (19.9 oz)
Accessories Furnished	HM8 adapter, YA2 threaded adapter		
Optional Accessories	PS2A phantom power supply, HM7C shock mount, HM48B, HM58B table arm, HM18AG pop filter, S65 windscreen, MS158E/BAG big mic stand		
Packaging	A3 protective carrying case, colorful outer packaging	A3 protective carrying case, colorful outer packaging	A3 protective carrying case, colorful outer packaging

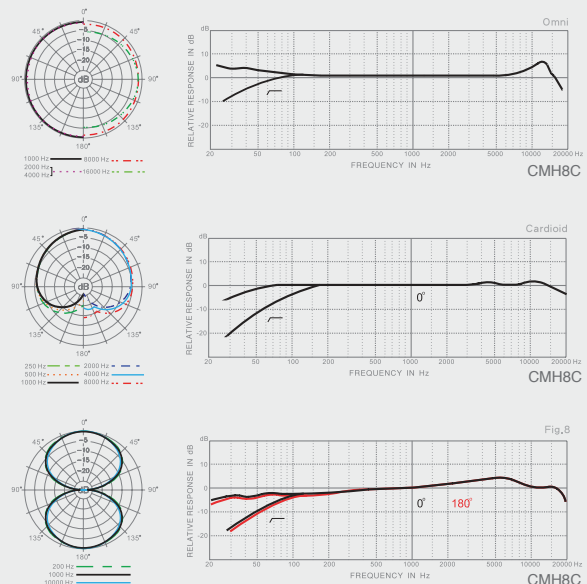

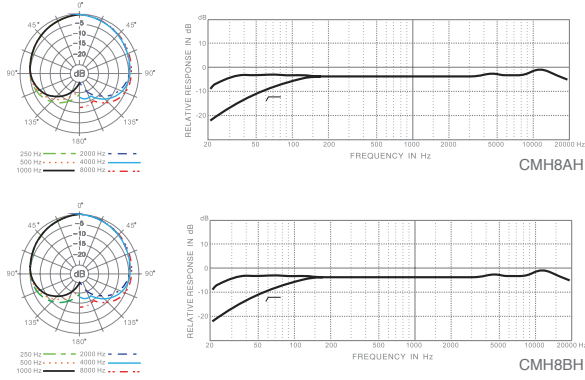

# CMH8AH CMH8BH CMH8CH

Large Diaphragm, "Smile Curve" Frequency Response

Studio / Broadcast / Vocal / Woods / String / Acoustic Guitar / Piano / Percussions / Western and Eastern Instruments

The CMH8H series microphones are similar to the CMH8C/B/A large diaphragm microphones except for an enhanced frequency response. These 3 black versions keep the same pattern variations as the CMH8 series but the external appearance has been changed and they have an extended frequency performance in the bass register and additional high frequency enhancement.

For convenience, an LED indicator will illuminate when phantom power is present.

- 1" gold-evaporated diaphragm
- FET custom transformer
- A5 protective plastic carrying case

CMH8AH: Internal low-cut switch

CMH8BH: Cardioid, external -10 dB pad and low-cut switches

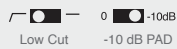

CMH8CH: Cardioid, Figure 8, & Omni patterns, external -10 dB pad and low-cut switches



HM26A shock mount

## Specifications

Model No.	CMH8AH	CMH8BH	CMH8CH
Type	True condenser, Ø1" (Ø25.4 mm)	True condenser, Ø1" (Ø25.4 mm)	True condenser, Ø1" (Ø25.4 mm), dual diaphragm
Polar Pattern	Cardioid	Cardioid	Figure 8 / Cardioid / Omni
Frequency Response	30-20,000 Hz	30-20,000 Hz	30-20,000 Hz
Low Frequency Filter	100 Hz (internal)	100 Hz	100 Hz
Pad	N/A	-10 dB	-10 dB
Sensitivity	-34 dBV/Pa (20 mV)	-34 dBV/Pa (20 mV)	-30.5 / -35.4 / -30.5 dBV/Pa (30 / 17 / 30 mV)
Output Impedance	200 Ω	200 Ω	200 Ω
Min. Load Impedance	1,000 Ω	1,000 Ω	1,000 Ω
S/N Ratio	76 dB	76 dB	80 / 76 / 80 dB
Equivalent Output Noise	18 dB	18 dB	14 / 18 / 14 dB
Max. SPL	132 dB SPL	142 dB SPL	138 / 142 / 138 dB SPL
Dynamic Range	114 dB	124 dB	124 dB
Power Requirements	48 VDC, 2.7 mA	48 VDC, 2.7 mA	48 VDC, 4 mA
Finish	Black	Black	Black
Connector	XLR3M	XLR3M	XLR3M
Dimensions	Ø54 x 200 mm (Ø2.13" x 7.87")	Ø54 x 200 mm (Ø2.13" x 7.87")	Ø54 x 200 mm (Ø2.13" x 7.87")
Net Weight	550 g (19.4 oz)	550 g (19.4 oz)	567 g (20 oz)
Accessories Furnished	HM8B adapter, YA2 threaded adapter, S65 windscreen, HM26A shock mount		
Optional Accessories	PS2A phantom power supply, HM48B, HM58B table arm, HM18AG pop filter, MS158 big mic stand		
Packaging	A5 protective carrying case, colorful outer packaging	A5 protective carrying case, colorful outer packaging	A5 protective carrying case, colorful outer packaging

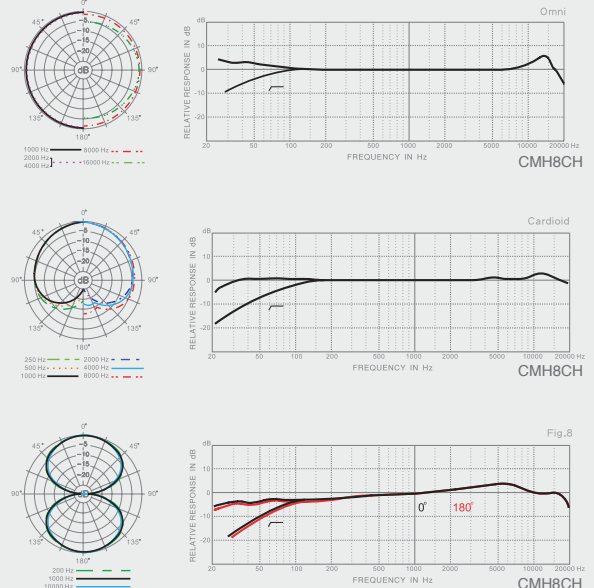



## L211

### Large Diaphragm Condenser Microphone

Studio / Broadcast / Vocal / Woods / String / Acoustic Guitar / Piano / Percussions / Western and Eastern Instruments

These all purpose studio-grade condenser microphones combine skillful workmanship with a 1-inch gold deposited diaphragm for the most vivid sound. There are a variety of optional accessories available to meet the requirements of almost all applications and settings. The L211 has a single diaphragm with fixed cardioid polar pattern. There is no external control switch, but there is an internal low cut filter. Making it the right choice for those on a limited budget.

- Large 1" diameter. Ultra thin 3mm membrane gold evaporated capsule
- Low noise transformer circuitry
- Internal low frequency roll-off switch
- Flat and wide frequency response
- Completed microphone packaged in a sturdy suitcase

#### Specifications

Type	Ture condenser, Ø1" (Ø25.4mm)
Polar Pattern	Cardioid
Frequency Response	30-20,000 Hz
Low Frequency Filter	100 Hz, (internal)
Sensitivity	-34 dBV/Pa (20 mV)
Output Impedance	200 Ω
Min. Load Impedance	1,000 Ω
S/N Ratio	76 dB
Equivalent Output Noise	18 dB
Max. SPL	132 dB SPL
Dynamic Range	114 dB
Power Requirements	48V DC, 2.7mA
Finish	Gold
Connector	XLR3M
Dimensions	Ø54 x 200 mm (Ø2.13" x 7.87")
Net Weight	550 g (19.4 oz)
Accessories Furnished	HM7 Shock mount, A5 Carrying Case
Optional Accessories	PS2A Phantom supplier, HM48B Table arm, HM58B Table arm, HM18AG Foam Windshield, S65 Windscreen foam, HM8 Standard rotatable connector, YA1 Metal screw adaptor, MS158/BAG BFW Big Foot Willie Adjustable Boom Stand
Packaging	Colorful outer packaging

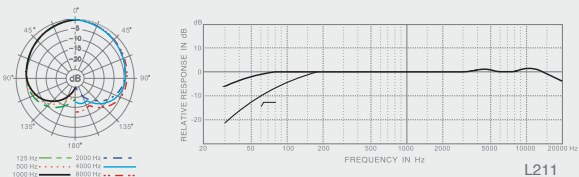

## PRO238MKII

### 1" True Condenser Vocal Microphone

Vocal / Studio / Live Recording / Strings / Winds / Piano / Percussion

The PRO238MKII is a handheld large diaphragm condenser microphone with an improved mechanical structure to lower handling noise. Its modular design makes it easy to remove/restore the capsule. The built-in low cut filter switch inside the chamber prevents accidental operation, letting the artist perform comfortably while holding the PRO238MKII. Thanks to its wide and extended frequency and optimized damping, the PRO238MKII exhibits a natural and lively sound. The PRO238MKII is the best microphone for live sound, broadcasting, and recording

- 1" gold-coated diaphragm
- Low handling noise
- Built-in low cut switch
- Warm, detailed sound suitable for vocals
- Extended frequency response with mid-high band emphasis tailors frequency response
- High dynamic range, low distortion

#### Specifications

Type	True condenser, Ø1" (Ø25.4 mm)
Polar Pattern	Cardioid
Frequency Response	20-20,000 Hz
Low Frequency Filter	100 Hz@12 dB/oct
Sensitivity	-40 dBV/Pa (10 mV)
Output Impedance	200 Ω
Min. Load Impedance	1,000 Ω
S/N Ratio	78 dB
Equivalent Output Noise	16 dB
Max. SPL	136 dB SPL
Dynamic Range	120 dB
Power Requirements	48V DC, <3.5 mA
Finish	Titanium grey
Connector	XLR3M
Dimensions	Ø50 x 182 mm (Ø1.97" x 7.17")
Net Weight	350 g (12.3 oz)
Accessories Furnished	S58 windscreen, HM38S mic clip with screw knob, YA2 threaded adapter, pouch
Optional Accessories	PS2 A phantom power supply, HM18AG pop filter, HM26B shock mount
Packaging	Colorful outer packaging

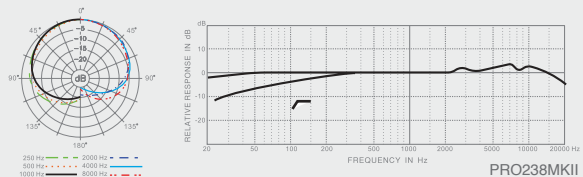



## S125

### 1/2" True Condenser Vocal Microphone

Studio Recording / Live Recording / Vocal / Strings / Winds / Percussion

The S125 is a 1/2" gold-evaporated diaphragm true condenser studio-grade microphone with extended frequency response, high definition vocal texture, accurate impact transient details, triple-layer windscreen to prevent close miking pop sound.

- 1/2" gold-coated diaphragm
- Built-in -10 dB pad switch
- Built-in 3rd order 150 Hz low cut filter (-18 dB/oct)
- Protective rubber cover on switch window to prevent accidental change
- Wide and uniform frequency response
- Shock mount capsule, very low handling noise
- Conductive shielding, extremely low inherent noise and RF immunity



### Specifications

Type	True condenser, Ø1/2" (Ø12.7 mm)
Polar Pattern	Cardioid
Frequency Response	20-20,000 Hz
Low Frequency Filter	150 Hz (18 dB/oct)
Pad	-10 dB
Sensitivity	-45 dBV/Pa (5.6 mV)
Output Impedance	250 Ω
Min. Load Impedance	1,000 Ω
S/N Ratio	76 dB
Equivalent Output Noise	18 dB
Max. SPL	148 dB SPL
Dynamic Range	130 dB
Power Requirements	48V DC, 3.5 mA
Finish	Titanium grey
Connector	XLR3M
Dimensions	Ø48 × 180 mm (Ø1.89" × 7.09")
Net Weight	350 g (12.3 oz)
Accessories Furnished	HM38S mic clip with screw knob, YA2 threaded adapter, Pouch
Optional Accessories	S40 windscreen, PS2A phantom power supply
Packaging	Colorful outer packaging

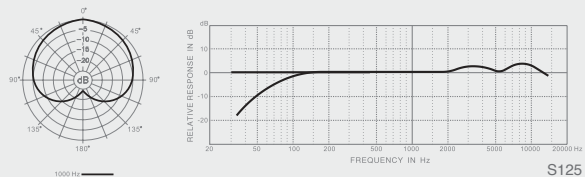

## E524D

### XY Stereo Condenser Microphone

Live Sound / Recording Studio / Strings / Piano / Woodwinds / Percussion

The E524D incorporates 2 electret condenser capsules in an XY 90° arrangement. This popular arrangement provides easy to achieve stereo high definition results. The E524D is suitable for live or stereo recording, with built-in blue LED indicator and powered by either battery or phantom power. It will meet the demands of both professionals and amateurs for a true stereo microphone.

- 2 back electret, Ø16 mm condenser capsules in an XY 90° arrangement
- Powered by 1.5V battery or 12 to 52V DC phantom power
- Balanced output
- Blue LED power on indicator
- Suitable for flash recorders

XY stereo record mode please refer to the appendix of stereo techniques

### Specifications

Type	Back electret, Ø16 mm (Ø0.63") (matched pair capsule)
Polar Pattern	Cardioid
Frequency Response	40-18,000 Hz
Sensitivity	-48 dBV/Pa (4 mV)
Output Impedance	200 Ω
Min. Load Impedance	1,000 Ω
S/N Ratio	72 dB
Equivalent Output Noise	22 dB
Max. SPL	134 dB SPL
Dynamic Range	112 dB
Power Requirements	Phantom: 12-52V DC, 2 mA Battery: 1.5V AA/UM3, 2 mA
Finish	Titanium grey
Connector	XLR5M
Dimensions	Capsule Ø23.5 mm (Ø0.93"), W78 × H216 mm (3.07" × 8.5")
Net Weight	340 g (12 oz)
Accessories Furnished	HM38 mic clip, DS01 table stand, S25 windscreen, pouch, 1.5V AA alkaline battery, FM5AMM 5-meter mic cable with XLR-5F-2 × XLR3M connectors
Optional Accessories	HM40C camera adapter
Packaging	A4 protective carrying case, colorful outer packaging

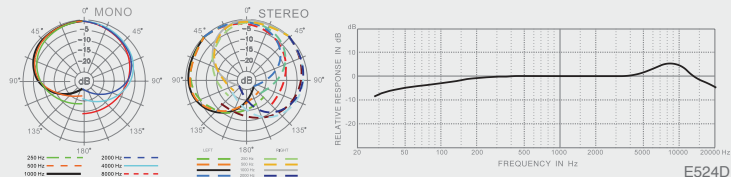



# S241

1/2" True Condenser

Pro Recording Studio / Live Recording / Vocals / Strings / Acoustic Guitar / Piano / Brass / Woodwinds / Percussion

The S241 is greatly appreciated by leading sound engineers because it is based on professional craftsmanship and top quality standards. The S241 is a 1/2" gold-evaporated diaphragm microphone with an inter-changeable capsule and low noise microphone pre-amplifier circuits. Its modular capsule design allows the user to change from cardioid to omni polar pattern as needed. The S241 is an ideal candidate for capturing the transient sounds from acoustic guitars, snare drums, hi-hats and overheads. All these features make the S241 a great tool for rental companies as standard equipment.

- 1/2" gold-evaporated diaphragm
- Flat and wide frequency response
- Modular capsule design
- -10 and -20 dB PAD settings
- 2nd order 75 Hz and 150 Hz switchable low-cut filters
- Laser-engraved serial numbering



Cardioid Capsule



Omni Capsule

Omni directional capsule for S241 to interchange from cardioid to omni in recording application. Extremely flat response from 20 Hz to 20 kHz.

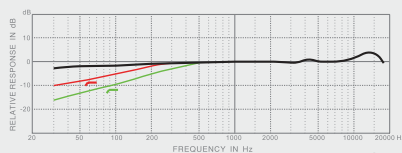
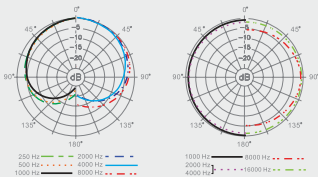

## Specifications



Type	True condenser, Ø1/2" (Ø12.7 mm)
Polar Pattern	Cardioid, omni (option)
Frequency Response	20-20,000 Hz
Low Frequency Filter	75 Hz, 150 Hz
Pad	-10, -20 dB
Sensitivity	-35 dBV/Pa (17.8 mV)
Output Impedance	200 Ω
Min. Load Impedance	1,000 Ω
S/N Ratio	78 dB
Equivalent Output Noise	16 dB
Max. SPL	143 dB SPL
Dynamic Range	127 dB
Power Requirements	48V DC, 3 mA
Finish	Titanium grey
Connector	XLR3M
Dimensions	Ø22 x 155 mm, Ø0.87" x 6.1"
Net Weight	220 g (7.8 oz)
Accessories Furnished	HM40 shock mount, YA2 threaded adapter, S09F windscreen, HM43 metal mesh pop screen
Optional Accessories	PS2A phantom power supply, HM26B shock mount, Omni capsule
Packaging	A3 protective carrying case, Colorful outer packaging



## S502 STEREO ORTF Stereo 1/2" True Condenser Microphone

Classical Music Recording / Location Recording / Studio Recording / Drums Recording

Utilizing the most popular stereo recording microphone technique, the S502 combines a pair of matched cardioid capsules in the ORTF arrangement, saving a lot of time to find that sweet spot for stereo recording. Superlux has combined the ORTF technique with its successful S241 and S125 1/2" true condenser technology to develop the S502 as a straight-forward design to provide experienced engineers the most convenient solution for stereo recording.

- 1/2" gold-evaporated diaphragm
- ORTF fixed standard capsule arrangement
- Sturdy metal body
- Balanced output
- Best for stereo sound field recording

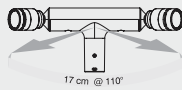

The ORTF stereo record mode please refer to the appendix of stereo techniques.

### Specifications

Type	True condenser, Ø1/2" (Ø12.7 mm) matched pair
Polar Pattern	Cardioid
Frequency Response	40-20,000 Hz
Sensitivity	-36 dBV/Pa (15.8 mV)
Output Impedance	200 Ω
Min. Load Impedance	1,000 Ω
S/N Ratio	76 dB
Equivalent Output Noise	18 dB
Max. SPL	135 dB SPL
Dynamic Range	117 dB
Power Requirements	48V DC, 4.5 mA
Finish	Black
Connector	XLR5M
Dimensions	Capsule: Ø22.5 mm (Ø0.89") W184.5 x H66.8 mm (7.26", 2.63")
Net Weight	245 g (8.6 oz)
Accessories Furnished	A3 protective carrying case, HM30 shock mount, 2 x S20 windscreens, FM0.6AMM microphone cable (0.6 m, 5-pin XLR 3F-2 x XLR-3M cable)
Packaging	A3 protective carrying case, Colorful outer packaging

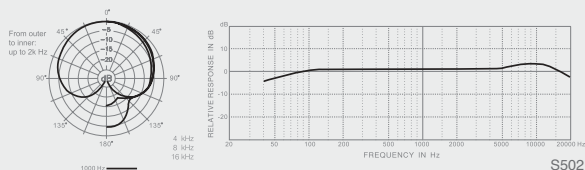

## S502MKII STEREO ORTF Stereo 1/2" True Condenser Microphone

Classical Music Recording / Location Recording / Studio Recording / Drums Recording

The Superlux S502 ORTF recording microphone has earned an outstanding reputation in the professional audio industry. Building on this success, Superlux is pleased to announce a new improved version, the S502MKII. The S502MKII features specialized diaphragm technology that provides better directivity, a lower S/N ratio and improved total harmonic distortion. The new Superlux S502MKII reveals more sound detail with extended high frequency response. Compared to the original S502, the new S502MKII delivers a flatter frequency response with a crystal-clear, natural sound quality that captures a wide stereo field with increased depth and realism. The Superlux S502MKII ORTF stereo microphone is a perfect choice for any professional recording or sound reinforcement application.

- 1/2" OD 3 µm ultra-thin diaphragm capsule
- Uniform frequency response
- ORTF fixed standard capsule arrangement
- Balanced output, best for stereo sound field recording
- Extra-low background noise

### Specifications

Type	True condenser, Ø1/2" (Ø12.7 mm) matched pair
Polar Pattern	Cardioid
Frequency Response	40-20,000 Hz
Sensitivity	-37 dBV/Pa (15.8 mV)
Output Impedance	200 Ω
Min. Load Impedance	1,000 Ω
S/N Ratio	79 dB
Equivalent Output Noise	15 dB (A-weighted, IEC/DIN651)
Max. SPL	134 dB (THD ≤ 1 % @ 1000 Hz)
Dynamic Range	117 dB
Power Requirements	48 V $\pm$ , 4.5 mA
Finish	Black
Connector	XLR5M
Pin Assignment	Left channel pin 2/3; Right channel pin 4/5; pin 2/4 connect to "+" signal; pin 1 connect to shield and ground
Dimensions	Capsule: Ø20 mm (Ø0.79"), Width 184.5 mm, High 66.8 mm (Width 7.26", High 2.63")
Net Weight	245 g (8.6 oz)
Accessories Furnished	A3 protective carrying case, HM30 shock mount, 2 x S20 windscreens, FM0.6AMM microphone cable (0.6 m, 5-pin XLR 3F-2 x XLR-3M cable)
Packaging	A3 protective carrying case, Colorful outer packaging

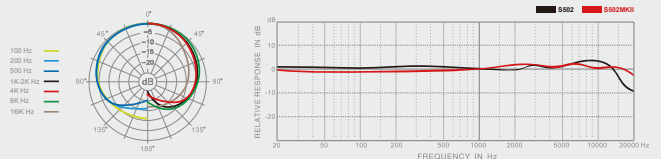

CMH8K/U/H/O: 3-Capsule pack with 1 each of the cardioid, super-cardioid and omni capsules

SMKH8K: Stereo pack with a pair of CMH8KU and one HM15 adapter

CMH8KU: Includes cardioid capsule

CMH8KH: Includes supercardioid capsule

CMH8KO: Includes omni capsule

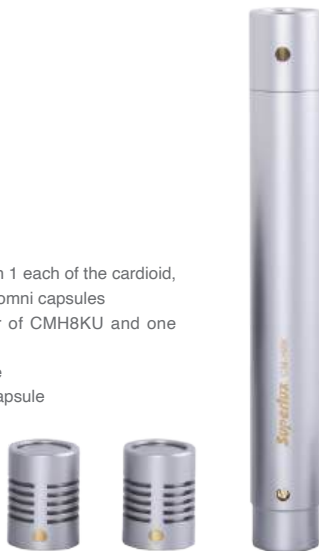

## CMH8K

### Electret Instrument

Live Recording / Lead Vocal / Strings / Acoustic Guitar / Piano / Brass / Woodwinds / Percussion

The CMH8K series is a pencil-type back electret condenser microphone with a inter-changeable capsule, good electro-acoustic characteristics and compact size. Its modular capsule design allows the user to change from cardioid to super cardioid or omni polar patterns as needed. The CMH8K series are suitable for the recording or live sound reinforcement of mid-high frequency instruments.

- Good transient response, high dynamic range, low distortion, delicate sound

#### Specifications



Type	Back electret, Ø16 mm (Ø0.63")
Polar Pattern	Cardioid, Supercardioid, Figure 8
Frequency Response	40-20,000 Hz
Sensitivity	-40 dBV/Pa (10 mV)
Output Impedance	200 Ω
Min. Load Impedance	1,000 Ω
S/N Ratio	72 dB
Equivalent Output Noise	22 dB
Max. SPL	134 dB SPL
Dynamic Range	112 dB
Power Requirements	48V DC, 3.5 mA
Finish	Champagne silver
Connector	XLR3M
Dimensions	Ø20 × 150 mm (Ø0.79" × 5.91")
Net Weight	170 g (6 oz)
Accessories Furnished	HM32 shock mount, YA2 threaded adapter, S08F windscreen, O-ring × 2
Optional Accessories	HM33 shock mount, PS2B phantom power supply
Packaging	A3 protective carrying case, Colorful outer packaging

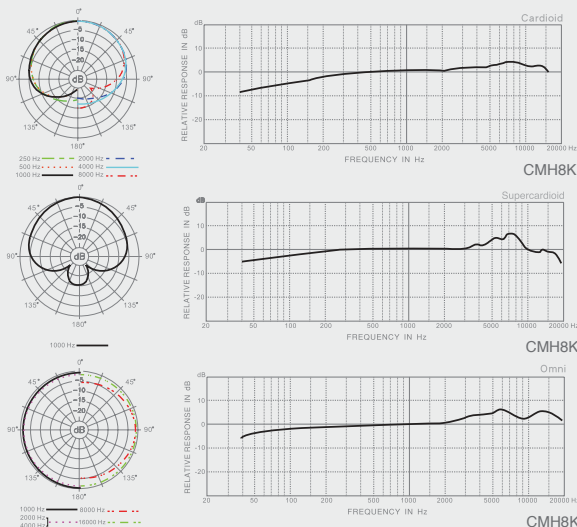

## E205

### Studio Condenser Microphone

Home Recording / Studio Recording / Live Show

Designed for critical home/project/professional studio applications and live performances, this side-address supercardioid studio condenser microphone delivers exceptional detail and low noise. Along with its rugged construction and high-performance specifications, the E205 provides an exceptional level of consistency from model to model.

- Large diaphragm for smooth, natural sound and low noise
- High SPL handling and wide dynamic range provide unmatched versatility
- Supercardioid polar pattern reduces pickup of sounds from the sides and rear, improving isolation of desired sound source

#### Specifications

Type	Back Electret Condenser
Polar Pattern	Supercardioid
Frequency Response	30-18,000 Hz
Sensitivity	-38 dBV / Pa (12.6 mV)
Output Impedance	200 Ω
Min. Load Impedance	1,000 Ω
S/N Ratio	72 dB
Equivalent Output Noise	< 22 dB
Max. SPL	> 135 dB
Dynamic Range	> 113 dB
Power Requirements	12 – 52 V $\overline{\text{DC}}$ , 3.5 mm
Finish	Black
Connector	XLR3M
Dimensions	Ø54 × 150 mm (Ø2.13" × 5.9")
Net Weight	400 g (14.1 oz)
Accessories Furnished	Pouch, YA2 threaded adapter, HM85 pivoting stand mount
Optional Accessories	HM26A Shock Mount
Packaging	Colorful outer packaging

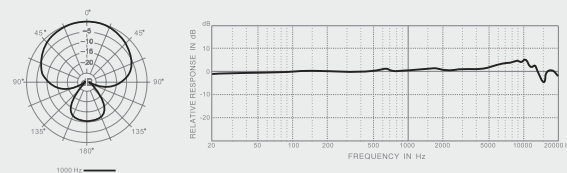

# Broadcast Microphones

## Classical Active Ribbon Microphone

### R102

Classical Ribbon Microphone

### R102MKII

MKII Full Bandwidth Ribbon Microphone up to 18 kHz

Broadcast / String / Bass section / E-Guitar / Percussion / Harmonica / Vocals

The R102 series ribbon microphone is especially designed for broadcast and TV recording. With the high sensitivity and flat frequency response as the condenser microphone, it also has the fastest transient response. The R102'S classical pure, warm sound texture is ideal for broadcast, strings, orchestra and stereo Blumlein recordings. It has also been well received when used on live stage music productions.

- Phantom power required
- High sensitivity, high dynamic range, low noise
- Low impedance output, low distortion
- Pre-amplifier with integrated shielding to provide EMI-free performance
- Figure 8 polar pattern, symmetrical front and back sensitivity
- Easy-to-replace ribbon module



R102MKII



R102 Capsule module

R102MKII Capsule module

R102

### Specifications



Model No.	R102MKII	R102
Type	Ribbon, 2.5 $\mu$ m	Ribbon, 2.5 $\mu$ m
Polar Pattern	Figure 8	Figure 8
Frequency Response	20-18,000 Hz	25-15,000 Hz
Sensitivity	-40 dBV/Pa (10 mV)	-40 dBV/Pa (10 mV)
Output Impedance	250 $\Omega$	250 $\Omega$
Min. Load Impedance	1,000 $\Omega$	1,000 $\Omega$
S/N Ratio	76 dB	76 dB
Equivalent Output Noise	18 dB	18 dB
Max. SPL	138 dB SPL	138 dB SPL
Dynamic Range	120	120 dB
Power Requirements	48V DC, 4 mA	48V DC, 4 mA
Finish	Dark grey with golden grille	Dark grey
Connector	XLR3M	XLR3M
Dimensions	60 x 44 x 196 mm (2.63" x 1.73" x 7.72")	60 x 44 x 196 mm (2.63" x 1.73" x 7.72")
Net Weight	500 g (17.6 oz)	500 g (17.6 oz)
Accessories Furnished	U-bracket, 6-meter right angle cable, HM31 shock mount, U-bracket, 6-meter right angle YA2 threaded adapter, HM63 cable pop filter, Pouch	
Optional Accessories	PS2A phantom power supply, HM48B, HM58B table arm	
Packaging	A3 protective aluminum carrying case, colorful outer packaging	

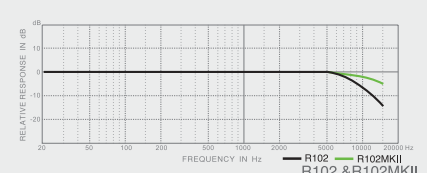
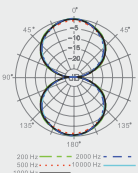



## D421

### Dynamic Broadcast Microphone

Studio Recording / Broadcast / Vocals

D421 is a broadcast dynamic microphone with flat and wide frequency response and low proximity effect. The natural and clear sound is suitable in broadcasting, vocal and studio application. The special-designed anti-electromagnetic can effectively isolate the electromagnetic interference generated by the computer and the screen. It can also reduce the mechanical noise.

- Flat and wide frequency response, suitable for podcasting, recording
- Special design structure, reduce the mechanical noise effectively
- Built-in two filters: low cut and mid-high boost
- The cardioid capsule can reduce the surrounding environment noise effectively
- The anti-electromagnetic design can isolate the computer from the electromagnetic interference
- Robust microphone body

### Specifications

Polar Pattern	Cardioid
Frequency Response	50-20,000 Hz
Sensitivity	-59 dBV / Pa (1.12 mV)
Output Impedance	150 Ω
Electromagnetic Hum Sensitivity (Typical, Equivalent SPL/milliOersted)	60 Hz: 11 dB, 500 Hz: 24 dB, 1 kHz: 33 dB
Connector	XLR
Dimensions	Ø62.12 x 204.5 mm (Ø2.44" x 8.05")
Net Weight	606 g (21.37 oz)
Accessories Furnished	Pouch, YA2 threaded adapter, HM85 pivoting stand mount
Optional Accessories	HM26A Shock Mount
Packaging	Colorful outer packaging

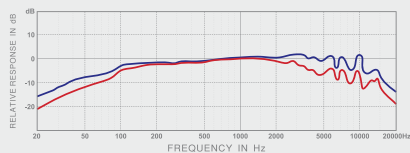

## CMH8E

### Large Diaphragm Condenser

Speech / Broadcast / String / Brass

The CMH8E is especially designed for broadcasters, instrument pick up and DAW recording with a custom closed-cell capsule design structure. Its immunity to environmental noise makes it especially suitable for use in a hostile audio environment.

- 1" diameter, gold-evaporated diaphragm
- Low noise FET custom transformer output circuit
- External 2-position low-cut filter
- U suspension mount and cable hanger

100 Hz, 150 Hz Low cut filter switch  
-10 dB pad switch

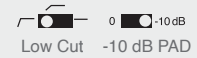
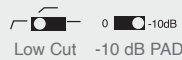

### Specifications



Type	True condenser, Ø1" (Ø25.4 mm)
Polar Pattern	Cardioid
Frequency Response	30-20,000 Hz
Low Frequency Filter	100 Hz, 150 Hz
Pad	-10 dB
Sensitivity	-38 dBV/Pa (12 mV)
Output Impedance	200 Ω
Minimum Output Impedance	1,000 Ω
S/N Ratio	76 dB
Equivalent Output Noise	18 dB
Max. SPL	145 dB SPL
Dynamic Range	127 dB
Power Requirements	48V DC, 2.7 mA
Finish	Champagne silver
Connector	XLR3M
Dimensions	Ø54 x 200 mm (Ø2.13" x 7.87")
Net Weight	600 g (2.1 oz)
Accessories Furnished	U bracket (cable clip included)
Optional Accessories	PS2A phantom power supply, S65 windscreen, HM48B table arm, HM58B table arm
Packaging	Colorful outer packaging

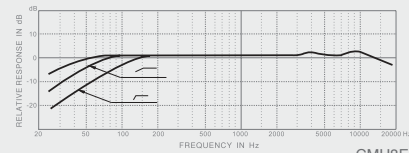
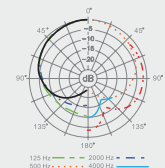



## E523D STEREO

### XY Stereo Electret

**Broadcast / TV / Pro Recording / Outdoor Production / Handheld Digital Recording**

The E523D incorporates 2 electret condenser capsules in an XY 90° arrangement. This popular arrangement provides easy to achieve, high definition stereo results. The E523D is suitable for TV production or outdoor stereo recording. A built-in blue LED indicates when microphone is powered by battery or phantom power. With balanced outputs for pro audio and video system use and a low-cut switch for reducing noise, it will meet the demands of both professionals and amateurs for a true stereo microphone.

- Matched pair capsules, XY stereo pick up
- Balanced outputs
- Powered by phantom or battery power
- Low-cut switch, locking device included

### Specifications

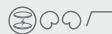

Type	Back electret, Ø9.7 mm (Ø0.38")
Polar Pattern	Cardioid
Frequency Response	50-18,000 Hz
Low Frequency Filter	150 Hz
Sensitivity	-47 dBV/Pa (4.4 mV)
Output Impedance	200 Ω
Min. Load Impedance	1,000 Ω
S/N Ratio	70 dB
Equivalent Output Noise	24 dB
Max. SPL	126 dB SPL
Dynamic Range	102 dB
Power Requirements	12-52V DC, 2 mA, battery 1.5V AA/UM3, 2 mA
Finish	Titanium grey
Connector	XLR5M
Dimensions	Capsule: 64 × 38 mm (2.52" × 1.5") Body: Ø23.5 × 218 mm (Ø0.93" × 8.58")
Net Weight	340 g (12 oz)
Accessories Furnished	HM38S mic clip with screw knob, YA2 threaded adapter, S50 windscreen, FM5AMM 5-meter mic cable with XLR5F~2 × XLR3M, Battery 1.5V, AA alkaline, Pouch
Optional Accessories	HM40C camera microphone shock mount, YA10 camera adapter
Packaging	Colorful outer packaging

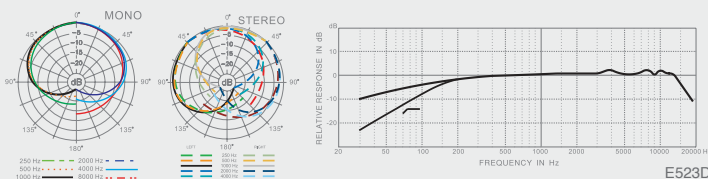

## PRA318

### Omni Interview

**SNG / ENG / Interview**

The PRA318L/S are Omni dynamic microphones for SNG, with a light weight aluminum alloy body, lengthened handle for easy reach and no proximity effect for the best speech recognition. It easily meets the requirements of professionals for an all-purpose interview microphone.

- Specific frequency response to help intelligibility
- No proximity effect
- Aluminum alloy body, light weight, solid structure
- Wind noise immunity, suitable for outdoor use

PRA318L Long shaft, 23 cm  
PRA318S Short shaft, 18 cm

### Specifications



Model No.	PRA318S	PRA318L
Type	Dynamic	Dynamic
Polar Pattern	Omni	Omni
Frequency Response	50-15,000 Hz	50-15,000 Hz
Sensitivity	-53 dBV/Pa (2.2mV)	-53 dBV/Pa (2.2mV)
Output Impedance	500 Ω	500 Ω
Sensitivity	500 Ω	500 Ω
Max. SPL	140 dB SPL	140 dB SPL
Finish	Black	Black
Connector	XLR3M	XLR3M
Dimensions	Ø34 × 180 mm (Ø1.34" × 7.09")	Ø34 × 230 mm (Ø1.34" × 9.06")
Net Weight	110 g (3.9 oz)	140 g (4.9 oz)
Accessories Furnished	S07 windscreen, HM30 shock mount, YA2 threaded adapter, pouch	
Optional Accessories	HM6 table stand, HM40C camera microphone shock mount	
Packaging	Colorful outer packaging	

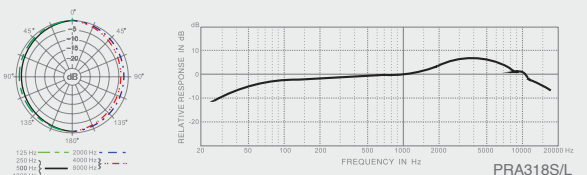

# CM9HL

## Shotgun Microphone

# WSK1

## Windscreen System



### Video Production / TV / ENG

CM9HL is a lightweight true condenser shotgun microphone which is designed especially for professional to apply in film production, video, television, narration and ENG industries.....etc. CM9HL features wide frequency response and consistent pickup quality while pickup in different angles, especially in mid-range and high frequency. Different from other shotgun microphones, CM9HL provides wider pickup directivity which makes it an ideal microphone in field recording application. When holding a boom pole, the off-axis performance of CM9HL makes it easier to keep the sound sources within its pickup area. CM9HL really improves the recording quality compared to the other shotgun microphones. Moreover, CM9HL is equipped with the high frequency boost to enhance the clarity of the speech intelligibility, a steep high-pass filter to remove noise from wind and boom, a mildness high-pass filter to compensate the proximity effect. There is also a pair of LED indication beside each high-pass filter to display on/off which are useful in dark environment. It is the blessing for audio engineer to assemble CM9HL onto the boom pole due to its lightweight.

- Lightweight, sturdy metal body
- Coloration of sound, extremely low coloration from off-Axis sound
- Great off-axis sound, more directivity than normal supercardioid microphone
- Great pickup effect, consistent pickup quality even if the microphone is rotated on its axis

How to solve the wind noise and handling noise is a big issue while doing recording at uncontrolled space like outdoors or noising air-conditioner. For improving the captured sound quality and reducing unwanted noise, the WSK1 windshield kit is accomplished and does an excellent job. WSK1's blimp windshield structure offers a good shield while you are working indoors, and gives extremely effect for the sound you are capturing. It will prevent the blowing noise from air conditioner. The included windjammer will be installed on the blimp and gives great ability to reduce strong wind noise outdoors. Different length of shotgun microphones can be installed in WSK1, like Superlux CM9HL, E525S/L. Convenient rubber handle and shock mount system will ensure handling noise will not appear in your recording. The 3/8" thread on the handle will allow WSK1 to be installed on a pole or a microphone stand. All the necessary features are considered in WSK1 windshield and shock mount kit for professional recording experts, and you may put in a microphone, start doing the recording and forget the annoying noise. You are ready go!

- Decreasing unwanted handling and wind noise
- Accommodates most shotgun microphones 325mm in length and 20-22.5mm diameter
- Built-in suspension system with internal spacing guide
- Lightweight skeleton handle with 3/8" thread mount for pole mount
- Windjammer windshield included, for outdoor use



WJ-01 Windjammer

### CM9HL Specifications

Types	True condenser, Ø1/2" (12.7 mm)
Polar Pattern	Supercardioid
Frequency Response	40-20,000 Hz
Filter	80Hz @18dB /oct, 300Hz @6dB/oct, 5dB boost at 10 kHz (shelving)
Sensitivity	-37 dBV / Pa (14.1 mV)
Output Impedance	600 Ω
Recommended impedance	600 Ω or greater
Equivalent Noise Level	15 dB-A
Max. SPL	130 dB SPL
Power Requirement	48V phantom, 4.5 mA
Max Output Voltage	1.2 V (@1k Hz, 1k Ω)
Finish	Champagne Silver
Connector	XLR3M
Dimensions	Ø21 × 252 mm (Ø0.82" × 9.92")
Net Weight	89 g (3.13 oz)
Accessories Furnished	S32 Foam Windscreen, B9 Microphone Clip, YA2 Adapter, Carrying Pouch
Optional Accessories	WJ-01 Windjammer, HM40C Camera microphone shock mount, HM40 Shock mount, BP-1 Pickup extension boom, WSK-1 Windscreen system, WJ-WSK1 Windjammer
Packaging	Colorful outer packaging

### WSK1 Specifications

Dimensions	H285 × W488 × D126 mm (11.2" × 19.2" × 4.96")
Net Weight	585 g (20.6 oz)
Packaging	Colorful outer packaging

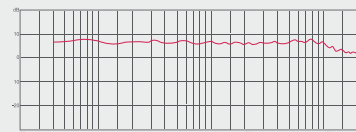

# PRA118

## Shotgun Microphone



Film / EFP / ENG / SNG / Theater / Live Sound

The PRA118 shotgun is a highly directional pro electret condenser microphone with a specifically tuned frequency response, making it exceptional at off-axis suppression. The PRA118 is suitable for film, EFP productions, theater sound reinforcement and SNG/ENG tasks.

- Exceptional off-axis suppression
- Very pure sound with no coloration
- Flat on-axis response

PRA118L 54 cm, S15 foam windscreen  
 PRA118S 34 cm, S14 foam windscreen

### Specifications



Model No.	PRA118S	PRA118L
Type	Back electret, Ø14mm (Ø0.55")	Back electret, Ø14mm (Ø0.55")
Polar Pattern	Shotgun	Shotgun
Frequency Response	30-16,000 Hz	30-16,000 Hz
Sensitivity	-35 dBV/Pa (17.8 mV)	-33 dBV/Pa (22.4 mV)
Output Impedance	200 Ω	200 Ω
Sensitivity	1,000 Ω	1,000 Ω
S/N Ratio	74 dB	76 dB
Equivalent Output Noise	20 dB	18 dB
Max. SPL	134 dB SPL	130 dB SPL
Dynamic Range	114 dB	112 dB
Power Requirements	12-52V DC	12-52V DC
Finish	Black	Black
Connector	XLR3M	XLR3M
Dimensions	Ø20 x 340 mm (Ø0.79" x 13.39")	Ø20 x 540 mm (Ø0.79" x 21.26")
Net Weight	200 g (7 oz)	250 g (8.8 oz)
Accessories Furnished	S14 windscreen for PRA118S, S15 windscreen for PRA118L HM37S mic clip with screw knob, YA2 threaded adapter	
Optional Accessories	PS2B phantom power supply, HM30 shock mount, HM35C camera microphone shock mount	
Packaging	Hand carrying bag, colorful outer packaging	

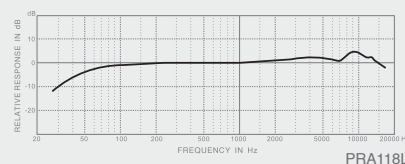
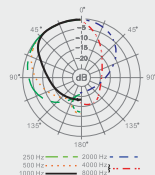
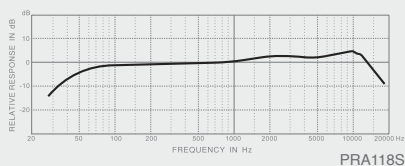
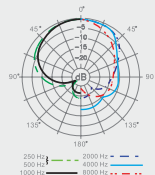

# PRA116B

## Shotgun Microphone, Battery Powered



Film / EFP / ENG / SNG / Theater / Live Sound

The PRA116B battery powered shotgun is a highly directional pro electret condenser microphone with a specifically tuned frequency response, making it exceptional at off-axis suppression. The PRA116B is suitable for film, EFP productions, theater sound reinforcement and SNG/ENG tasks. The PRA116B is battery-powered for easy connection to video camera equipment.

- Exceptional off-axis suppression
- Very pure sound with no coloration
- Flat on-axis response
- Battery powered
- External low cut switch

### Specifications



Type	Back electret, Ø9.7 mm (Ø0.38")
Polar Pattern	Shotgun
Frequency Response	50-14,000 Hz
Low Frequency Filter	80 Hz, 12 dB/oct
Sensitivity	-41 dBV/Pa (9 mV)
Output Impedance	600 Ω
Sensitivity	2,000 Ω
S/N Ratio	74 dB
Equivalent Output Noise	20 dB
Max. SPL	119 dB SPL
Dynamic Range	99 dB
Power Requirements	Battery 1.5 V AA/UM3, 2 mA
Finish	Black
Connector	XLR3M
Dimensions	Ø21 x 370 mm (Ø0.83" x 14.57")
Net Weight	220 g (7.76 oz)
Accessories Furnished	HM37S mic clip with screw knob, YA2 threaded adapter, HM40C camera microphone shock mount, S14 windscreen, 1.5V AA alkaline battery
Optional Accessories	HM30 shock mount, HM35C camera microphone shock mount
Packaging	Hand carrying bag, colorful outer packaging

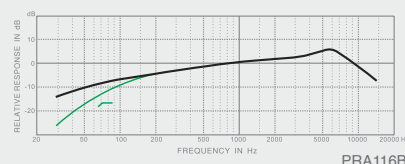
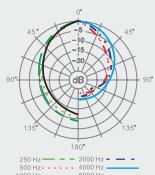



MS Stereo

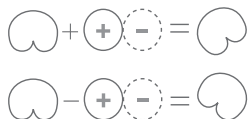

## E525 STEREO

### Stereo Condenser Shotgun Microphone

Film / EFP / ENG / SNG / Theater / Live Sound

The E525 is a stereo condenser shotgun microphone with figure 8 side microphone for MS stereo recording. It has 4-output formats for MS, XY-wide, XY-narrow and Mono. The E525 is suitable for location, film, EFP and theater sound pick up or SNG/ENG program use.

- 2 stereo record modes, MS& XY(W/N)
- External low-cut switch
- Exceptional off-axis suppression
- Very pure sound with no coloration
- Aluminum alloy, light weight



ON / OFF

E525S short 235 mm

E525L long 380 mm

### Specifications



Model No.	E525S	E525L
Type	Back electret, Ø14 mm (Ø0.55")	Back electret, Ø14 mm (Ø0.55")
Polar Pattern	MS/XY stereo shotgun	MS/XY stereo shotgun
Frequency Response	20-20,000 Hz	20-20,000 Hz
Low Frequency Filter	100 Hz, 12 dB/oct	100 Hz, 12 dB/oct
Sensitivity	-34 dBV/Pa (9.0 mV)	-34 dBV/Pa (9.0 mV)
Output Impedance	200 Ω	200 Ω
Min. Load Impedance	1,000 Ω	1,000 Ω
S/N Ratio	72 dB	72 dB
Equivalent Output Noise	22 dB	22 dB
Max. SPL	127 dB SPL	127 dB SPL
Dynamic Range	105 dB	105 dB
Power Requirements	12-52V	12-52V
Finish	Titanium grey	Titanium grey
Connector	XLR5M	XLR5M
Dimensions	Ø21.5 × 235 mm (Ø0.85" × 9.3")	Ø21.5 × 380 mm (Ø0.85" × 14.97")
Net Weight	103 g (3.6 oz) S32 windscreen	153 g (5.4 oz) S33 windscreen
Accessories Furnished	HM40C camera mic shock mount, HM37S mic clip with screw knob, YA2 threaded adapter, FM0.6AMM, 0.6-meter cable with XLR5F~2 × XLR3M connector, pouch	
Optional Accessories	HM35 shock mount, HM35C camera microphone shock mount	
Packaging	Hand carrying bag, colorful outer packaging	

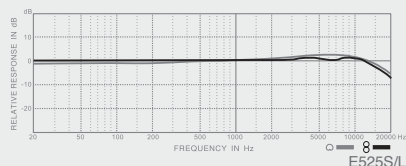
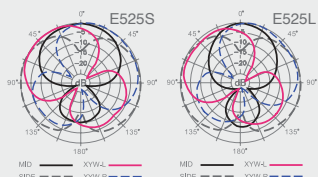

# USB Microphones

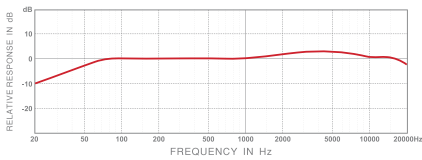

Cardioid

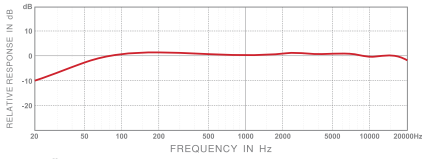

8-figure



## E431U

### Multi-Pattern condenser USB Microphone

#### Home Recording / Studio Recording / Instruments

E431U is equipped with dual Ø14mm back-electret capsules which deliver crisp and dynamic sound reproduction. It features three different pattern settings which makes it easy to select the best pickup pattern for different professional recording requirements. E431U features a 3.5 mm standard headphone jack for real-time and zero-latency monitoring. It is also possible to adjust the microphone gain through the knobs at the front of the microphone. It is unnecessary to operate the microphone via complicated driver. All you need is to plug the USB cable into the USB socket of a computer and to follow some simple system operation to start recording.

- USB digital recording condenser microphone, multi-pattern function to offer the best pickup pattern under different recording requirements
- 24 bit, 192 kHz sampling rate, equipped with high quality A / D converter for excellent sound quality
- Featured with headphone jack and individual volume control for zero-latency monitoring, the built-in headphone amplifier ensures extremely clear and rich playback details even at high volume
- Flat and wide frequency response perfect for podcasting, home studio, live recording and narrating
- Plug-and-play, compatible with Windows and Mac OS.

#### Specifications

Type	Back electret capsules, 2 × Ø14 mm (Ø0.55")
Polar Pattern	Cardioid / 8-figure / Omni
Frequency Response	20-20,000 Hz
Sensitivity	-38 dBV/Pa (12.6 mV)
Output Impedance	> 16 Ω
Max. SPL	108 dB (THD < 1% at 1 kHz)
Power Requirements	USB (5 V DC)
Bit Depth	24 bit
Sampling Rate	192 kHz
Volume Control	Direct monitoring volume control, headphone monitoring volume control
Output Jack	USB C-Type
Headphone output power	150 mW (at 1 kHz, 1% T.H.D., 16 Ω)
T.H.D.	< 0.5 % (at 1 kHz)
Headphone output jack	Ø3.5 mm stereo mini jack
Finish	Black
Dimensions	230 × 90 × 55 mm (9" × 3.5" × 2.2")
Net Weight	509 g (17.9 oz)
Accessories Furnished	1.5-meter type-C USB cable, Die-cast table stand
Optional Accessories	HM61 Elastic suspension shock mount
Packaging	Hand carrying bag, colorful outer packaging

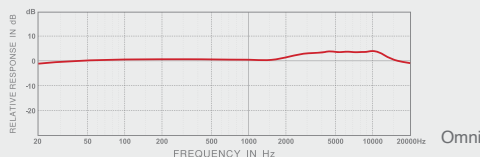

Omni



## L401U

### 1" Large Diaphragm USB Microphone

#### Home Recording / Studio Recording / Instruments

It is equipped with a 1", 3µm ultra-thin gold-plated diaphragm capsule to ensure studio-grade recording quality in any stage, home or studio environment. The plug-and-play design of the L401U large diaphragm USB microphone ensures compatibility with both Windows and Mac operating systems and supports the majority of available DAW software. The high-quality A to D converter and USB output of the L401U makes accurate recording effortless. L401U features a zero-latency stereo headphone monitoring (3.5mm) jack to provide real-time microphone input monitoring. A direct/mixing knob allows you to adjust the monitoring level between mic input and audio output easily. The L401U large diaphragm microphone is a quality tool that is the right choice for any professional stage, home or studio application.

- USB digital recording condenser microphone, plug-and-play, compatible with Windows and Mac OS system and supports most of the DAW software
- Ø1", 3 µm ultra-thin gold-plated diaphragm capsule of L401U captures exquisite and warm sound, the cardioid pickup pattern of L401U is very suitable for vocal recording, acoustic instruments and any other sources
- The built-in headphone amplifier ensures extremely clear and rich playback details even under high volume, direct monitoring provides zero-latency monitoring, built-in high quality AD converter, and with 24 bit, 192 kHz sampling rate

#### Specifications

Type	True condenser, Ø1" (Ø25.4 mm)
Polar Pattern	Cardioid
Frequency Response	20-20,000 Hz
Sensitivity	-34 dBV/Pa (20 mV/Pa)
Impedance	> 16 Ω
Max. SPL	110 dB (THD < 1% , at 1 kHz)
Power Requirements	Powered by USB (5 V DC)
Bit Depth	24 bit
Sampling Rate	24 bit / 192 kHz
Volume Control	Direct / mixing monitoring volume control, headphone monitoring volume control
Output Jack	USB connector
Headphone output power	150 mW (at 1 kHz, 1% T.H.D., 16 Ω)
T.H.D.	< 0.5 % (at 1 kHz)
Headphone output jack	Ø3.5 mm stereo mini jack
Finish	Black
Dimensions	Ø105 × 254.8 mm (Ø4.13" × 10.03")
Net Weight	1200 g (42.3 oz)
Accessories Furnished	3M Type-B USB cable, Die-cast table stand, Foam windscreen
Optional Accessories	HM60 Elastic suspension shock mount
Packaging	Hand carrying bag, colorful outer packaging

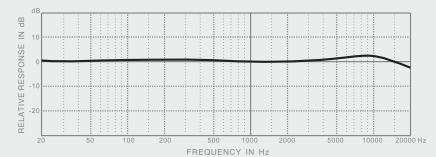
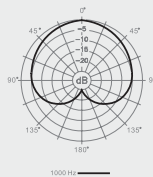



## E205U

### USB Condenser Microphone

Home Recording / Studio Recording / Instruments

The E205U is a high-quality condenser microphone with an advanced A/D and USB interface which gives you digital recording capabilities instantly with no external digital interface or software driver required. It is USB compatible with Mac, Windows, and most DAW software programmes, including GarageBand. The E205U offers premium quality audio recording with ease and mobility, and with its mic stand mount adapter and 9.8 ft. (3-meter) USB cable, the E205U is a valuable kit for any project studio.

- Smooth, flat frequency response
- Plug in and start recording, no drivers required
- Up to 16 bit / 48 kHz sampling rate
- Powered by USB power, no external power required
- Headphone output and volume control

#### Specifications

Type	Back electret
Polar Pattern	Supercardioid
Frequency Response	30 - 18,000 Hz
Sensitivity	-38 dBV/Pa (12.6 mV) (@1,000 Hz Open Circuit Voltage)
Max. SPL	>135 dB
Power Requirements	USB 5 V $\equiv$ , < 30 mA
Resolution	Up to 16 bit/48k Hz sampling rate
Finish	Champagne silver
Connector	USB B-Type, 1/8" (3.5 mm) phone connector
Dimensions	Ø54 x 150 mm (Ø2.13" x 5.9")
Net Weight	422 g (14.9 oz)
Accessories Furnished	YA2 threaded adapter, HM85 pivoting stand mount, Pouch, 3M USB cable, Table tripod DS01
Packaging	Colorful outer packaging

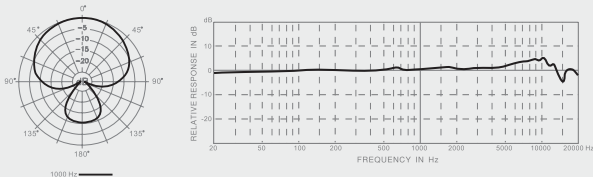

## E205UMKII

### USB Condenser Microphone

Home Recording / Studio Recording / Instruments

E205UMKII is the upgraded version of USB condenser microphone E205U, which is specialized in delivering high resolution audio and flat and wide frequency response. E205UMKII can be operated with Windows and Mac OS systems. It is very suitable for Podcasting and personal recording.

The equipped headphone socket and the headphone volume gain control make real-time monitoring easier and better!

- Delivering the high resolution audio with up to 24 bit / 96 kHz sampling rate
- Smooth and flat frequency response perfect for podcasting and home studio recording
- Compatible with Windows and Mac OS system
- Equipped with headphone output jack and gain control for easy and perfect real-time monitoring

#### Specifications

Type	Back Electret Condenser
Polar Pattern	Supercardioid
Frequency Response	20 - 20,000 Hz
Sensitivity	-35 dBV / Pa (12.6 mV) (@1,000 Hz)
Max. SPL	>135 dB
Power Requirements	USB 5V
Resolution	Up to 24 bit / 96 kHz sampling rate
Finish	Black, White, Rose gold
Connector	USB B-TYPE, 1/8" (3.5 mm) mini jack
Dimensions	Ø54 x 150 mm (Ø2.13" x 5.9")
Net Weight	422 g (14.9 oz)
Accessories Furnished	YA2 threaded adapter, HM85 pivoting stand mount, Pouch, 3-meter cable, DS01 Table stand
Packaging	Colorful outer packaging

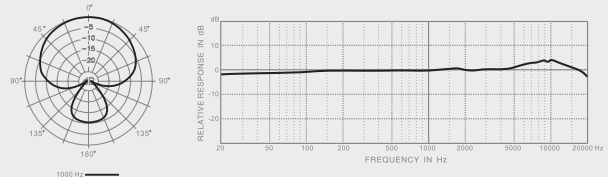



**Vocal  
Headworn  
Lavalier  
Microphones**

# Vocal Microphones



## D108MKII

### Dynamic Podcast Microphone

#### Studio / Live Recording / Vocal

Returning to our roots, Superlux embarks on a new journey in fundamental microphone research. The first-generation Superlux D108, known for its consistent directional characteristics, has effectively addressed live sound amplification challenges for many professionals. In the upgraded version, D108MKII, we strive for a higher level, integrating over three decades of Superlux's profound understanding of microphones. Carefully designed frequency response curves faithfully reproduce the natural tones of the human voice. Its consistent directionality not only enhances the microphone's penetration but also significantly increases gain before feedback. Furthermore, handheld noise has always been a concern for many microphone users. In the D108MKII, Superlux, through a deep understanding of low-frequency curves and directional characteristics, coupled with continuous practical experience, has developed a new type of shock mount, significantly reducing handling noise. Every word spoken and every song sung is exceedingly complex. However, it is this very complexity that allows us to convey our emotions and individuality fully. It is nature's most beautiful gift to us, enriching human interaction. The D108MKII diaphragm possesses outstanding transient response and high SPL, ensuring rapid and distortion-free reaction to sound source pressure, showcasing a high level of vocal detail reproduction. Superlux has always been committed to enhancing product technology and quality. The upgrade and redesign of the D108MKII not only astonish professionals but also provide live users with professional-grade recording quality. Let us look forward to D108MKII enhancing your musical journey, delivering a superior musical experience.

- The consistent directionality not only enhances the microphone's penetration but also significantly increases the gain before feedback
- Carefully designed frequency response faithfully reproduces the natural tones of the human voice
- The new shock mount design significantly reduces handling noise
- Outstanding transient response and high SPL of the diaphragm ensure rapid and distortion-free reaction to sound source pressure after receiving the sound source pressure

The D108MKII model is the D108SMKII with an ON / OFF switch.



D108MKII Dynamic Podcast Microphone Kit

#### Specifications

Type	Dynamic
Polar Pattern	Supercardioid
Frequency Response	50-18,000 Hz
Sensitivity	-54 dBV/Pa (2 mV)
Output Impedance	200 Ω
Max. SPL	150 dB SPL
Finish	Black
Connector	XLR3M
Dimensions	Ø50 x 182 mm (Ø1.96" x 7.16")
Net Weight	430 g (15.16 oz)
Kit Net Weight	3.54 kg (124.9 oz)

D108MKII / D108SMKII Single package:  
 HM38S Microphone Clip  
 D108MKII Kit-package:  
 Accessories Furnished A5 Carrying Case, HM26B Universal Shockmount, D2 Zinc-alloy Diecast Table Stand, HM38S Microphone Clip, CFM2.5FRM 2.5-meter XLR Cable (right-angle female connector)

Packaging Colorful outer packaging



D108MKII  
Section View

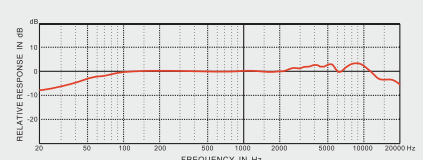
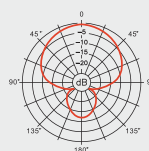

# TM58

## Vocal Microphone

### Studio / Live Recording / Vocal

TM58 series cardioid dynamic microphones are able to deliver authentic sound without any unnecessary sound coloration which are designed for speech and performance. Equipped with tailored diaphragm and precise directivity, TM58 series give full and powerful sound.

The higher SPL and high-grade transient response of TM58 series compared with other microphones will make the stage performance strong and the penetrating. TM58 is the correct choice for the perfectionists no matter outdoors or indoors, speech or performance.

- Balanced and clear true sound
- Frequency response is good for intelligent recognition and the mid-high frequency band is bright, the low frequency band is solid powerful
- High SPL capacity
- ON / OFF switch with locking function
- Newly-designed capsule shock mount

The TM58 model is the TM58S with an ON / OFF switch.

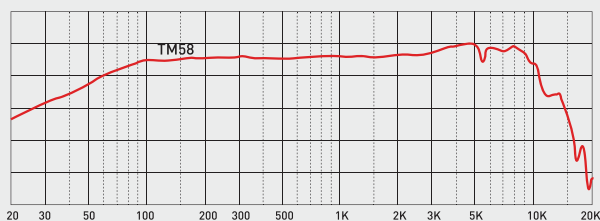
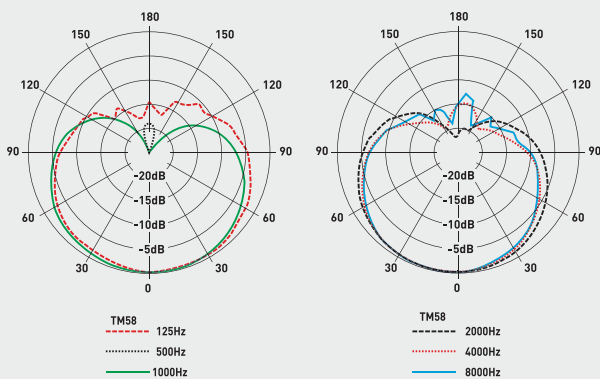

### Using a handheld microphone

For best signal to noise ratio, distance from the handheld microphone to the sound source shall be as short as possible. For higher gain before feedback and lowest background noise, the microphone shall be pointed directly to the sound source. (refer to the illustration below) The sensitivity of a super cardioid microphone is highest on axis and lowest at 120 to 135 degrees. To avoid interference between multiple microphones, each sound source shall be picked-up by one microphone, use as less microphones as possible in one space, or turn-on as less microphones as possible at the same time. To reduce crosstalk between microphones, an 1:3 guide line shall be follow: The distance between microphone A to the sound source A is "1", the distance between any other microphone to the sound source A shall be more than 3 times. When the (super) cardioid microphone get closer to the sound source, the low frequency response is boosted, as so call "proximity effect". Experience singer takes advantages of the proximity effect to improve the richness of his/her voice or to increase the bass of the instrument as if an extremely high quality equalizer is used. Same idea to reduce the bass by increase the distance to reduce the bass when needed. Reflecting surface affect sound as well. Beware of these surfaces such as wall, table, or floor. Place the microphone away from the hard surfaces or directly contact these surfaces to form a pressure zone microphone. When using the microphone outdoor or in windy environment, additional foam wind screen helps to reduce wind noise. Keep grill pop screen clean to avoid degrading the sound quality. Do not expose the microphone at high humidity/temperature environment to avoid damage.

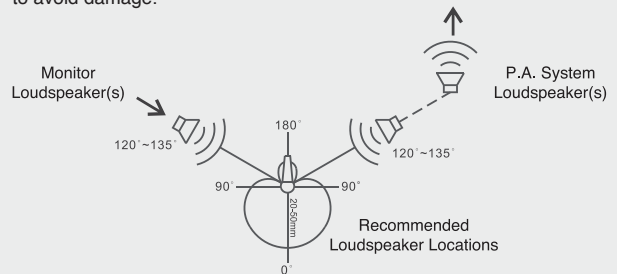

### Specifications

Type	Dynamic
Polar Pattern	Cardioid
Frequency Response	50-18,000 Hz
Sensitivity	-53 ± 2 dB, 1Pa = 94dB SPL
Rated impedance	500 Ω
Max. SPL	155 dB SPL (THD ≤ 1% 1kHz)
Finish	Metal structure, grey, namel -painted , matte finished
Connector	Integral 3 pin male XLR type
Dimensions	Ø51 x 163 mm (Ø2" x 6.41")
Net Weight	320 g (11.28 oz)
Accessories Furnished	HM9A Microphone cli, YA3 adaptor
Optional Accessories	S40 Foam windscreen, various color, HM6 Table stand, DS01 Table stand, MS131 Microphone stand
Packaging	Colorful outer packaging



## PRO238MKII

### 1" True Condenser Vocal Microphone

Vocal / Studio / Live Recording / Strings / Winds / Piano / Percussion

The PRO238MKII is a handheld large diaphragm condenser microphone with an improved mechanical structure to lower handling noise. Its modular design makes it easy to remove/restore the capsule. The built-in low cut filter switch inside the chamber prevents accidental operation, letting the artist perform comfortably while holding the PRO238MKII. Thanks to its wide and extended frequency and optimized damping, the PRO238MKII exhibits a natural and lively sound. The PRO238MKII is the best microphone for live sound, broadcasting, and recording

- 1" gold-coated diaphragm
- Low handling noise
- Built-in low cut switch
- Warm, detailed sound suitable for vocals
- Extended frequency response with mid-high band emphasis tailors frequency response
- High dynamic range, low distortion

#### Specifications

Type	True condenser, Ø1" (Ø25.4 mm)
Polar Pattern	Cardioid
Frequency Response	20-20,000 Hz
Low Frequency Filter	100 Hz @ 12 dB/oct
Sensitivity	-40 dBV/Pa (10 mV)
Output Impedance	200 Ω
Min. Load Impedance	1,000 Ω
S/N Ratio	78 dB
Equivalent Output Noise	16 dB
Max. SPL	136 dB SPL
Dynamic Range	120 dB
Power Requirements	48V DC, < 3.5 mA
Finish	Titanium grey
Connector	XLR3M
Dimensions	Ø50 x 182 mm (Ø1.97" x 7.17")
Net Weight	350 g (12.3 oz)
Accessories Furnished	S58 windscreen, HM38S mic clip with screw knob, YA2 threaded adapter, pouch
Optional Accessories	PS2 A phantom power supply, HM18AG pop filter, HM26B shock mount
Packaging	Colorful outer packaging

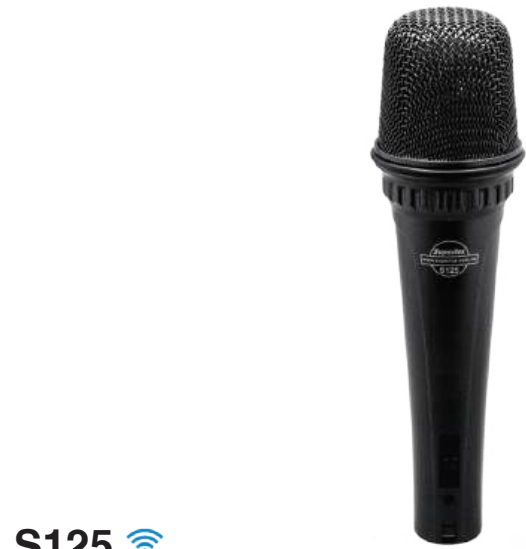
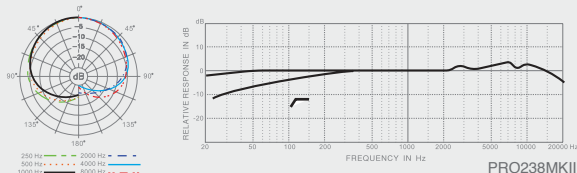

## S125

### 1/2" True Condenser Vocal Microphone

Studio Recording / Live Recording / Vocal / Strings / Winds / Percussion

The S125 is a 1/2" gold-evaporated diaphragm true condenser studio-grade microphone with extended frequency response, high definition vocal texture, accurate impact transient details, triple-layer windscreen to prevent close miking pop sound.

- 1/2" gold-coated diaphragm
- Built-in -10 dB pad switch
- Built-in 3rd order 150 Hz low cut filter (-18 dB/oct)
- Protective rubber cover on switch window to prevent accidental change
- Wide and uniform frequency response
- Shock mount capsule, very low handling noise
- Conductive shielding, extremely low inherent noise and RF immunity



#### Specifications

Type	True condenser, Ø1/2" (Ø12.7 mm)
Polar Pattern	Cardioid
Frequency Response	20-20,000 Hz
Low Frequency Filter	150 Hz (18 dB/oct)
Pad	-10 dB
Sensitivity	-45 dBV/Pa (5.6 mV)
Output Impedance	250 Ω
Min. Load Impedance	1,000 Ω
S/N Ratio	76 dB
Equivalent Output Noise	18 dB
Max. SPL	148 dB SPL
Dynamic Range	130 dB
Power Requirements	48V DC, 3.5 mA
Finish	Titanium grey
Connector	XLR3M
Dimensions	Ø48 x 180 mm (Ø1.89" x 7.09")
Net Weight	350 g (12.3 oz)
Accessories Furnished	HM38S mic clips with screw knob, YA2 threaded adapter, Pouch
Optional Accessories	S40 windscreen, PS2A phantom power supply
Packaging	Colorful outer packaging

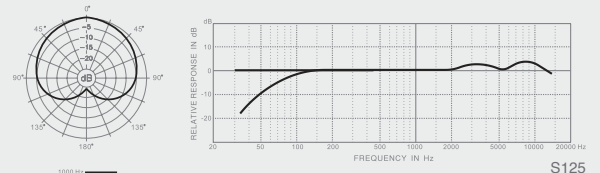



## PRO238C

### Vocal Condenser Microphone

Lead Vocal / Strings / Winds / DAW

The PRO238C is a versatile cardioid condenser microphone with superb electro-acoustic characteristics and anti-roll appearance. This microphone is ideal for live stage and instrument amplification, midi and DAW. Owing to its low handling noise, it is also used in professional handheld vocal, and for conferences and interviews.

- Optimal low frequency response and proper elevation in mid-high frequency band
- High SPL durability, wide dynamic range
- Low handling noise and double layer POP filter
- Anti-roll structure design

### Specifications

Type	Back electret, Ø14 mm (Ø0.55")
Polar Pattern	Cardioid
Frequency Response	50-16,000 Hz
Sensitivity	-44 dBV/Pa (6.3 mV)
Output Impedance	200 Ω
Min. Load Impedance	1,000 Ω
S/N Ratio	70 dB
Equivalent Output Noise	24 dB
Max. SPL	136 dB SPL
Dynamic Range	112 dB
Power Requirements	9-52V DC, 3 mA
Finish	Titanium blue
Connector	XLR3M
Dimensions	Ø45 x 180 mm (Ø1.77" x 7.09")
Net Weight	240 g (8.5 oz)
Accessories Furnished	HM38S clip with screw knob, YA2 threaded adapter
Packaging	A1 protective carrying case, Colorful outer sleeve

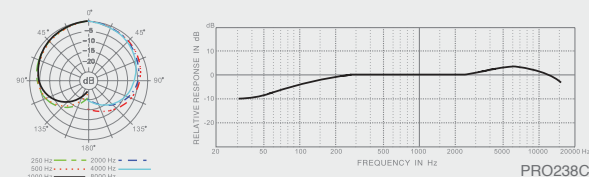

## TOP248

### Vocal Dynamic Microphone

Lead Vocal / Back-Up Vocal / Speech

The TOP248 microphone is designed for professional vocal and instrument live sound applications. This dynamic supercardioid microphone incorporates neodymium magnets and aluminum voice coil on a double membrane diaphragm. Due to the 60-240 Hz band boosting, the TOP248 sound is more powerful on the low frequency band, yet has great texture detail on the high frequency band. The TOP248 is ideally suited for lead vocals in popular music, soul and Jazz.

- Typical vocal frequency response
- Powerful on the low frequency band and more texture detail on the high frequency band
- High gain before feedback
- Low handling noise

The TOP248S model is the TOP248 with a lockable ON / OFF switch.

### Specifications

Type	Dynamic
Polar Pattern	Supercardioid
Frequency Response	50-16,000 Hz
Sensitivity	-54 dBV/Pa (2 mV)
Output Impedance	300 Ω
Min. Load Impedance	300 Ω
Max. SPL	150 dB SPL
Finish	Black
Connector	XLR3M
Dimensions	Ø54 x 180 mm (Ø2.13" x 7.09")
Net Weight	340 g (12 oz)
Accessories Furnished	HM38S clip with screw knob, YA2 threaded adapter, Pouch
Packaging	Colorful outer packaging

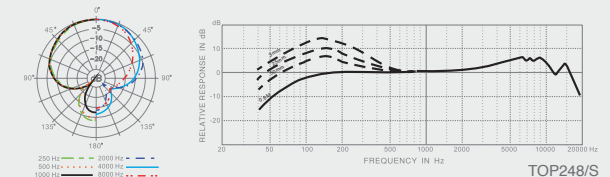



## TOP258

### Vocal Dynamic Microphone

Lead Vocal / Back-Up Vocal / Speech / Winds / Strings / Percussion

The TOP258 microphone with flat grille is designed for professional vocal and instrument live sound applications. This dynamic supercardioid microphone incorporates neodymium magnets and an aluminum voice coil on a double membrane diaphragm. Due to the 60-240 Hz band boosting, the TOP258 sound is more powerful on the low frequency band, while having more texture detail on the high frequency band to meet professional demands. The TOP258 is equally suitable for strings and percussion.

- Wide frequency response
- Highly intelligible speech reproduction
- High gain before feedback
- Low handling noise
- Suitable for instrument miking

### Specifications



Type	Dynamic
Polar Pattern	Supercardioid
Frequency Response	50-16,000 Hz
Sensitivity	-54 dBV/Pa (2 mV)
Output Impedance	300 Ω
Min. Load Impedance	300 Ω
Max. SPL	150 dB SPL
Finish	Black
Connector	XLR3M
Dimensions	Ø54 × 180 mm (Ø2.13" × 7.09")
Net Weight	345 g (12.2 oz)
Accessories Furnished	HM38S clip with screw knob, YA2 threaded adapter, Pouch
Optional Accessories	S40 windscreens
Packaging	Colorful outer packaging

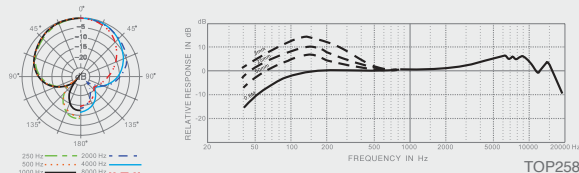

## PRO248

### Vocal Dynamic Microphone

Lead Vocal / Back-Up Vocal

The PRO248 microphone is a professional dynamic supercardioid microphone incorporating reinforced grille, neodymium magnets and an aluminum voice coil on a double membrane diaphragm. Its output transformer gives the PRO248 a wide frequency response, high sensitivity, better directivity and natural sound with more detail. The PRO248 is suitable for professional live stage performance and studio recording.

- Typical vocal frequency response
- Powerful on the low frequency band, more texture detail on the high frequency band
- High gain before feedback

The PRO248S model is the PRO248 with an ON / OFF switch.

### Specifications



Type	Dynamic
Polar Pattern	Supercardioid
Frequency Response	50-16,000 Hz
Sensitivity	-54 dBV/Pa (2 mV)
Output Impedance	300 Ω
Min. Load Impedance	300 Ω
Max. SPL	150 dB SPL
Finish	Titanium blue
Connector	XLR3M
Dimensions	Ø52 × 165 mm (Ø2.05" × 6.5")
Net Weight	PRO248: 270 g (9.5 oz) PRO248S: 285 g (10 oz)
Accessories Furnished	HM38S clip with screw knob, YA2 threaded adapter
Packaging	A1 protective carrying case, Colorful outer sleeve

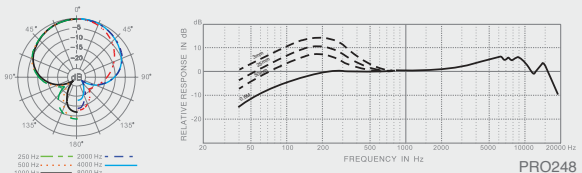



# PRO258

## Vocal Dynamic Microphone

**Lead Vocal / Back-Up Vocal / Woodwinds / Strings / Percussion**

The PRO258 microphone with flat grille is designed for professional vocal and instrument live sound applications. This dynamic supercardioid microphone incorporates neodymium magnets, an aluminum voice coil on a double membrane diaphragm, and an output transformer. It gives the PRO258 a wide frequency response and high sensitivity. Its warm, natural sound makes the PRO258 equally suitable for professional vocals, instrument recording, and live performance.

- Wide frequency response
- High intelligible speech reproduction
- High gain before feedback
- Excellent for strings and percussion

### Specifications



Type	Dynamic
Polar Pattern	Supercardioid
Frequency Response	50-16,000 Hz
Sensitivity	-54 dBV/Pa (2 mV)
Output Impedance	300 Ω
Min. Load Impedance	300 Ω
Max. SPL	150 dB SPL
Finish	Titanium blue
Connector	XLR3M
Dimensions	Ø42 x 165 mm (Ø1.65" x 6.5")
Net Weight	280 g (9.9 oz)
Accessories Furnished	HM38S clip with screw knob, YA2 threaded adapter
Packaging	A1 protective carrying case, Colorful outer sleeve

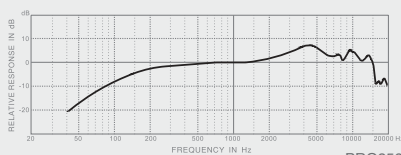
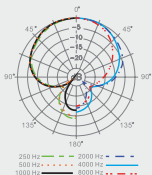

PRO258



# WH5

## Classic Microphones

Vocal / Drum / Instrument

The Superlux WH5 dynamic microphone is a trilogy concept microphone with 3 different capsules built-in so that the user can select one of the capsule for the preferred sound. Classic appearance is integrated with the latest microphone technology for artists who demand a unique "oldies" appearance with "goodies" music performance. The external 3-position capsule switch control selects the right capsule for drums, instrument or vocal pick up.

- Classical appearance, latest technology
- 3 different frequency response capsules in one body
- Typical application for percussion, instrument, and vocal
- On/off control, and 3-position capsule selection control
- Internal shock mount for reducing handling noise
- Tilt limit, and position set mechanism for 45° forward and 80° backward setting
- Chrome polish finish for long-term operation and collection

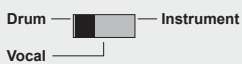

3-position capsule switch control  
Drum, Vocal, Instrument

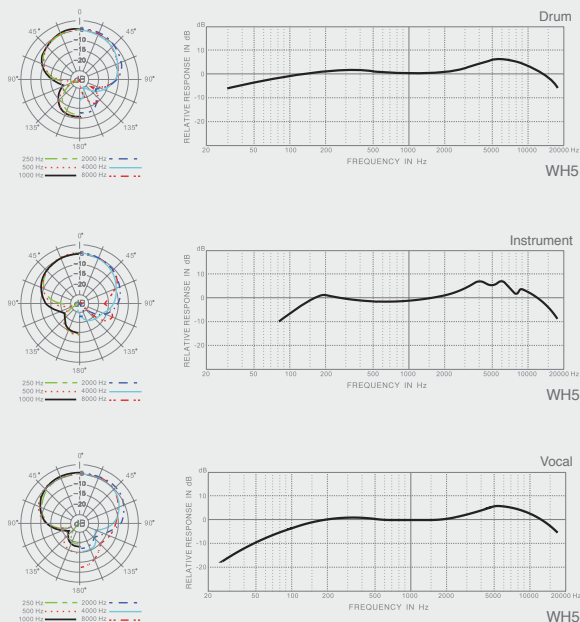

### Specifications

Type	Dynamic
Polar Pattern	Supercardioid
Frequency Response	Drum: 30-10,000 Hz Vocal: 50-16,000 Hz Instrument: 20-12,500 Hz
Sensitivity	Drum: -62 dBV/Pa (0.8mV) Vocal: -54 dBV/Pa (2.0mV) Instrument: -55 dBV/Pa (1.8mV)
Output Impedance	200 Ω
Min. Load Impedance	200 Ω
Max. SPL	Drum: 147 dB SPL Instrument: 134 dB SPL Vocal: 134 dB SPL
Finish	Chrome plated
Connector	XLR3M
Dimensions	Ø80 x 76.5 x 200 mm (Ø3.15" x 3.01" x 7.87")
Net Weight	750 g (26.4 oz)
Accessories Furnished	D1 table stand, YA2 threaded adapter
Packaging	White Box



## D107

### Vocal Dynamic Microphone

## D108

### Vocal Dynamic Microphone

#### Lead Vocal / Back-Up Vocal

The Superlux D107 and D108 series are a milestone in the world of professional vocal microphones, exhibiting exceptionally uniform on-axis and off-axis frequency response. The D107 series inherits the balanced tone, natural sound profiles, and structure of the D108 series. With its more compact and ergonomically-designed body and easy handling, the D107 series brings a new concept in professional vocal use.

The Superlux D107 and D108 series are supercardioid directivity; it suppressed the sound come from the side, and reduces the coloration and acoustic feed back. The modular design of the capsule with its gold-plated connectors permits easy separation of the grille and capsule from the body of the microphone, facilitating maintenance.

The Superlux D107 and D108 series have the same voicing, D107 series is a smaller version of the D108 series, they comes with two versions: the D107A and D108A are designed for recording with tailored vocal sound and ideal for close miking; the D107B and D108B are best for live sound performance with a tailored bass punch response.

- Flat and clear true sound
- Frequency response is good for intelligent recognition and the mid-high frequency band is bright, the low frequency band is solid powerful
- High gain before feedback
- High SPL capacity
- ON / OFF switch with locking function
- Module capsule design, capsule or grille can be turned counterclockwise for easy replacement
- Gold-plated connectors

	Application	Tone
D107A D108A	Recording	Meet proximity effect curve, best for close miking
D107B D108B	PA	Low frequency boost for more solid sound

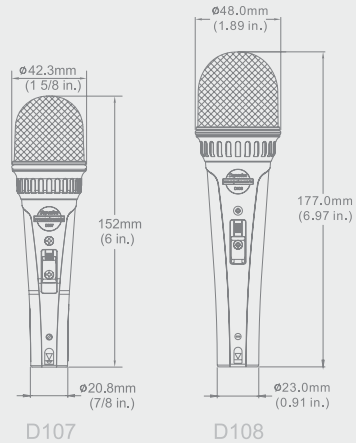
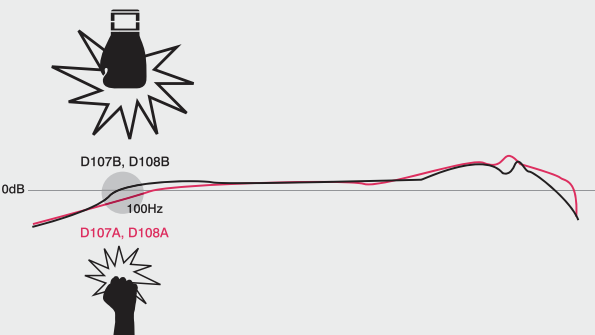

#### Specifications

Type	Dynamic
Polar Pattern	Supercardioid
Frequency Response	50-16,000 Hz
Sensitivity	-54 dBV/Pa (2 mV)
Output Impedance	250 Ω
Min. Load Impedance	250 Ω
Max. SPL	150 dB SPL
Finish	D107A / D108A: Titanium grey D107B / D108B: Black
Connector	XLR3M
Dimensions	D107: Ø42.3 × 152 mm (Ø1.67" × 5.98") D108: Ø48 × 177 mm (Ø1.89" × 6.97")
Net Weight	D107: 188 g (6.6 oz) D108: 290 g (10.2 oz)
Accessories Furnished	HM38S clip with screw knob, YA2 threaded adapter, Pouch
Optional Accessories	S40 windscreen
Packaging	Colorful outer packaging

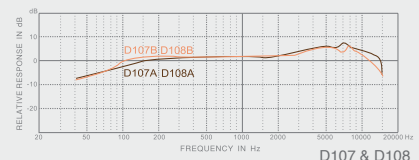
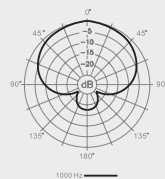



## D109

### High Impedance Microphone

#### Guitar Amplifier Microphone / High-Impedance Input Device

The D109 is a high impedance, supercardioid dynamic microphone. It has a flat mesh grille, which is an effective pop screen filter against wind noise and close miking. The D109 is an ideal microphone for vocal reinforcement from a guitar amp with a high impedance microphone input or other high impedance input devices.

- High-impedance output
- Clean instrument pick up
- High gain before feedback
- Neodymium magnet with double convex diaphragm
- High signal to noise ratio

#### Specifications

Type	Dynamic
Polar Pattern	Supercardioid
Frequency Response	80-12,500 Hz
Sensitivity	-38 dBV/Pa (12.6 mV)
Output Impedance	20k $\Omega$
Min. Load Impedance	100k $\Omega$
Max. SPL	130 dB SPL
Finish	Titanium grey
Connector	XLR3M
Dimensions	$\varnothing 48 \times 173$ mm ( $\varnothing 1.89" \times 6.81"$ )
Net Weight	340 g (12 oz)
Accessories Furnished	6-meter mic cable with XLR3M to 6.3 mm TS connector, HM38S clip with screw knob, YA2 threaded adapter, Pouch
Optional Accessories	CP838 low impedance balanced output converter, S40 windscreen
Packaging	Colorful outer packaging

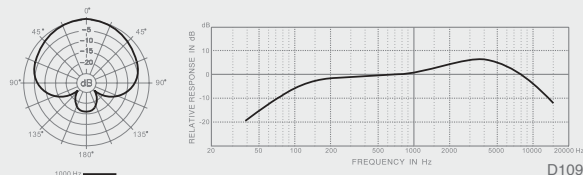

## D103

### Vocal Dynamic Microphone

#### Vocal / Karaoke

The D103 serial microphone is featuring a shock mount capsule structure, double-layer dome diaphragm design that extends the high frequency band response, increases the linear and stability of the capsule movement. The vocal sounds powerful and with lots of detail, the reinforced grille structure makes the D103 serial the best for the karaoke.

- High quality ND magnet
- Wide dynamic range
- High SPL capacity
- Reinforced grille
- Choose from 4 colors and 2 cables

D103/01P	matte black with XLR-6.3 mm cable
D103/01X	matte black with XLR-XLR cable
D103/02P	matte grey XLR-6.3 mm cable
D103/02X	matte grey XLR-XLR cable
D103/13P	matte silver XLR-6.3 mm cable
D103/13X	matte silver XLR-XLR cable
D103/49P	matte golden XLR-6.3 mm cable
D103/49X	matte golden XLR-XLR cable

#### Specifications

Type	Dynamic
Polar Pattern	Supercardioid
Frequency Response	50-15,000 Hz
Sensitivity	-52 dBV/Pa (2.5 mV)
Output Impedance	500 $\Omega$
Min. Load Impedance	500 $\Omega$
Max. SPL	150 dB SPL
Finish	D103 / 01 matte black D103 / 02 matte grey D103 / 13 matte silver D103 / 49 matte golden
Connector	XLR3M
Dimensions	$\varnothing 51.5 \times 165$ mm ( $\varnothing 2.03" \times 6.5"$ )
Net Weight	300 g (10.6 oz)
Accessories Furnished	HM38 mic clip, YA3 threaded adapter, 5-meter mic cable with XLR to 6.3 mm TS connector (P), 5-meter mic cable with XLR to XLR connector(X)
Packaging	Colorful outer packaging

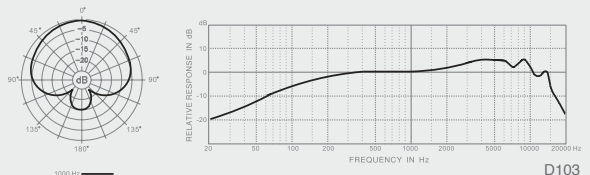



## FH12

### Vocal Dynamic Microphone

Lead Vocal / Back-Up Vocal

The FH12 and FH12S are vocal microphone of Sonata Series. Featuring a new style pop screen grille and a capsule that can be exchanged simply by un-screwing the cartridge, the FH12 is a supercardioid dynamic microphone that delivers excellent sonic performance. Its transient response and directivity is the professional's best choice.

- Modular design, capsule exchangeable
- High suppressed ambient noise
- High SPL capacity, high dynamic range, low distortion
- Low output impedance
- Powerful ND magnet, high sensitivity

The FH12S model is the FH12 with an ON / OFF switch.

#### Specifications



Type	Dynamic
Polar Pattern	Supercardioid
Frequency Response	50-16,000 Hz
Sensitivity	-56 dBV/Pa (1.6 mV)
Output Impedance	250 Ω
Min. Load Impedance	250 Ω
Max. SPL	134 dB SPL
Finish	Grey
Connector	XLR3M
Dimensions	Ø49 × 177 mm (Ø1.93" × 6.97")
Net Weight	400 g (14.1 oz)
Accessories Furnished	HM16S mic clip with screw knob, YA2 threaded adapter
Optional Accessories	S40 windscreen
Packaging	A2 protective carrying case, Colorful outer packaging

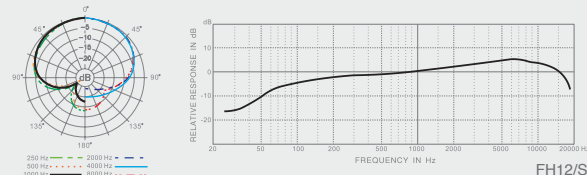

## FI10

### Instrument or Vocal Dynamic Microphone

Vocal / Strings / Woodwinds / Percussion

The FI10 is an instrument microphone of Sonata Series. Featuring a new style pop screen grille and a capsule that can be exchanged simply by un-screwing the cartridge, the FI10 is a supercardioid dynamic microphone that delivers excellent sonic performance. Its transient response and directivity is the professional's best choice.

- Exchangeable capsule
- Supercardioid directivity
- High SPL capacity, wide dynamic range, low distortion
- Low output impedance
- Powerful ND magnet, high sensitivity
- Dual membrane dome diaphragm
- Extended high frequency band
- Steel mesh, zinc alloy body
- Flat metal pop filter that is suitable for all instrument sound pick up

#### Specifications



Type	Dynamic
Polar Pattern	Supercardioid
Frequency Response	50-18,000 Hz
Sensitivity	-56 dBV/Pa (1.6 mV)
Output Impedance	250 Ω
Min. Load Impedance	250 Ω
Max. SPL	134 dB SPL
Finish	Grey
Connector	XLR3M
Dimensions	Ø49 × 173 mm (Ø1.93" × 6.81")
Net Weight	395 g (13.9 oz)
Accessories Furnished	HM16S mic clip with screw knob, YA2 threaded adapter
Optional Accessories	S40 windscreen
Packaging	A2 protective carrying case, Colorful outer packaging

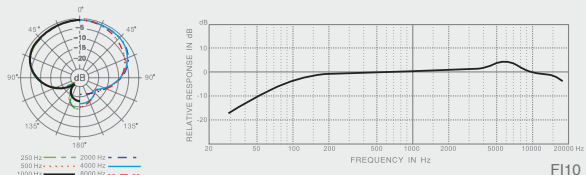



## PRAC

### Vocal Dynamic Microphone

Vocal / Speech

The PRAC series is the most popular supercardioid vocal microphone. It has a typical vocal frequency response, sturdy body structure, round metal grille design, and an on/off switch. This mic set has 3 different packages to meet the demands of stage work.

- Typical vocal frequency response
- Powerful on low frequency band, more texture detail on high frequency band
- High gain before feedback
- 3 different packages

PRAC1	1 PRAC package
PRAC3	3 PRAC package
PRAC5	5 PRAC package

### Specifications



Type	Dynamic
Polar Pattern	Supercardioid
Frequency Response	50-16,000 Hz
Sensitivity	-54 dBV/Pa (2 mV)
Output Impedance	200 Ω
Min. Load Impedance	1,000 Ω
Max. SPL	140 dB SPL
Finish	Grey
Connector	XLR3M
Dimensions	Ø53 x 180 mm (Ø2.09" x 7.09")
Net Weight	363 g (12.8 oz)
Accessories Furnished	HM42A mic clip, YA2 threaded adapter
Optional Accessories	S40 windscreen
Packaging	C1: A2 protective carrying case, Colorful outer packaging C3, C5: A3 protective carrying case, Colorful outer packaging

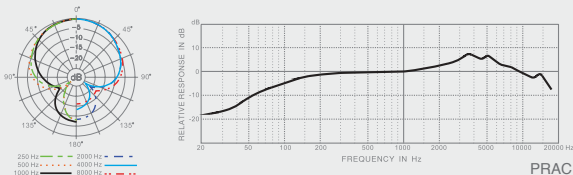

PRAC



## PRAD

### Vocal Dynamic Microphone

Vocal / Speech / Percussion

The PRAD series is the most popular supercardioid vocal/instrument microphone, it has a typical vocal frequency response, sturdy body structure, flat metal grille design is also suitable for instrument sound pick up. This mic set has 3 different packages to meet the demands of stage work.

- Flat metal grille design
- Typical vocal frequency response
- Powerful on low frequency band, more texture detail on high frequency band
- High gain before feedback
- Powerful ND magnet, high sensitivity
- 3 different packages

PRAD1	1 PRAD package
PRAD3	3 PRAD package
PRAD5	5 PRAD package

### Specifications



Type	Dynamic
Polar Pattern	Supercardioid
Frequency Response	50-16,000 Hz
Sensitivity	-54 dBV/Pa (2 mV)
Output Impedance	200 Ω
Min. Load Impedance	1,000 Ω
Max. SPL	140 dB SPL
Finish	Grey
Connector	XLR3M
Dimensions	Ø53 x 180 mm (Ø2.09" x 7.09")
Net Weight	370 g (13 oz)
Accessories Furnished	HM42A mic clip, YA2 threaded adapter
Optional Accessories	S40 windscreen
Packaging	D1: A2 protective carrying case, Colorful outer packaging D3, D5: A3 protective carrying case, Colorful outer packaging

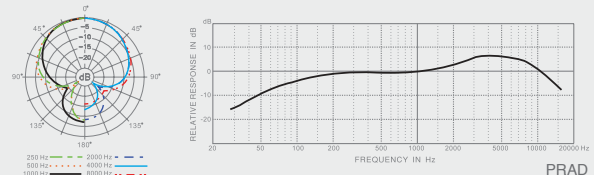

PRAD



## ECO88S

### Vocal Dynamic Microphone

#### Vocal / Speech

The ECO88S 6 PACK has a 6 in one package, with zinc alloy body, reinforced grille and supercardioid directivity. It is built for the user and suitable for all applications, which makes this economic design the best value choice.

- 6 pack, high value
- Nd magnet capsule, high sensitivity
- Reinforced metal grille

#### Specifications



Type	Dynamic
Polar Pattern	Supercardioid
Frequency Response	80-12,000 Hz
Sensitivity	-53 dBV/Pa (2.2 mV)
Output Impedance	500 Ω
Min. Load Impedance	500 Ω
Max. SPL	130 dB SPL
Finish	Titanium blue
Connector	XLR3M
Dimensions	Ø54 × 180 mm (Ø2.13" × 7.09")
Net Weight	250 g (8.8 oz)
Accessories Furnished	HM9A mic clip, YA2 threaded adapter, Pouch
Packaging	Colorful outer packaging

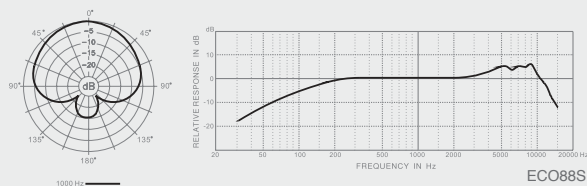

## EOA1

### Vocal Microphone

#### Vocal / Speech

EOA1 is specially designed by the consideration of economic and practicality for use in stage sound reinforcement.

- Nd magnet capsule, high sensitivity
- Zinc alloy die-casting case
- A skid-proof design at the end of the mic

#### Specifications



Type	Dynamic
Polar Pattern	Supercardioid
Frequency Response	80-12,000 Hz
Sensitivity	-53 dBV/Pa (2.2 mV)
Output Impedance	500 Ω
Min. Load Impedance	500 Ω
Max. SPL	130 dB SPL
Finish	Black
Connector	XLR3M
Dimensions	Ø51 × 175 mm (Ø2" × 6.89")
Net Weight	210 g (7.4 oz)
Accessories Furnished	HM9A mic clip, punch
Packaging	Blister packaging

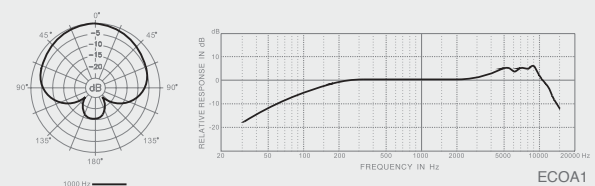



## PRA20 Headworn Dynamic Microphone

### Speeches / Presentations / Conferences

The PRA20 is a head-worn dynamic microphone with no proximity effect when used in close miking applications, avoiding those unwanted "pop" sounds. These microphones have a light-weight, comfortable steel wire design and a tailored vocal frequency response that increases the intelligibility of speech. The PRA20 does not require phantom power and is especially suitable for all vocal miking.

- Strong and flexible gooseneck allows precise placement of microphone to capture the perfect sound
- No proximity effect, excellent wearing comfort, smooth, natural sound

PRA20 1/8" (3.5 mm) TRS screw-on connector  
 PRA20TQG TA4F connector for wireless  
 PRA20XLR XLR3M connector

## PRA30 Headworn Condenser Microphone

### Vocals / Guitarists / Dancers / Drummers

The PRA30 is a high-quality headworn condenser microphone with an elastic steel frame, adjustable headband and no proximity effect, thereby avoiding those unwanted "pop" sounds when used in close miking applications. The PRA30 microphone provides a tailored vocal frequency response that increases intelligibility, making it especially suitable for singers or active dancers who can't use a handheld microphone.

- Strong and flexible gooseneck microphone, allows precise placement of microphone to capture the perfect sound
- Adjustable headband insures a perfect fit, smooth, natural sound
- Excellent comfort, temperature and humidity protection structure

PRA30 1/8" (3.5 mm) TRS connector  
 PRA30TQG TA4F connector, for wireless system  
 PRA30XLR TA3F connector for a PS-418S preamp (powered by phantom)  
 PRA30DXLR TA3F connector for a PS-418D preamp (either battery or phantom)

### Specifications

Model No.	PRA20	PRA30	PRA30TQG	PRA30XLR	PRA30DXLR
Type	Dynamic	Back electret, Ø14 mm (Ø0.55")	Back electret, Ø14 mm (Ø0.55")	Back electret, Ø14 mm (Ø0.55")	Back electret, Ø14 mm (Ø0.55")
Polar Pattern	Cardioid	Supercardioid	Supercardioid	Supercardioid	Supercardioid
Frequency Response	50-15,000 Hz	50-15,000 Hz	50-15,000 Hz	50-15,000 Hz	50-15,000 Hz
Low Frequency Filter	N/A	N/A	N/A	N/A	80Hz, 12dB/oct
Sensitivity	-64 dBV/Pa (0.6 mV)	-46 dBV/Pa (5 mV)	-35 dBV/Pa (17.8 mV)	Phantom: -40 dBV/Pa (10 mV)	Phantom: -42 dBV/Pa (7.9 mV) Battery: -44 dBV/Pa (6.3 mV)
Output Impedance	200 Ω	200 Ω	200 Ω	200 Ω	Phantom: 200 Ω, Battery: 270 Ω
Minimum Load Impedance	1,000 Ω	1,000 Ω	1,000 Ω	1,000 Ω	1,000 Ω
S/N Ratio	N/A	N/A	N/A	70 dB	68 dB
Equivalent Output Noise	N/A	N/A	N/A	24 dB	26 dB
Max. SPL	136 dB SPL	N/A	N/A	136 dB SPL	Phantom: 132 dB SPL, Battery: 118 dB SPL
Dynamic Range	N/A	N/A	N/A	112 dB	Phantom: 106 dB, Battery: 92 dB
Power Requirements	N/A	2.5-9V DC	2.5-9V DC	Phantom: 12-52V DC, 3.5 mA	Phantom: 9-52V DC, 3.5 mA, Battery: 1.5V AA/UM3
Finish	Black	Black	Black	Black	Black
Connector	PRA20: 3.5 mm TRS PRA20TQG: TA4F for wireless system PRA20XLR: XLR3M 1.5-meter cable	3.5 mm TRS, 1.5-meter cable	TA4F, 1.5-meter cable	TA3F, 1.5-meter cable	TA3F, 1.5-meter cable
Dimensions	Width: 155 mm (6.1") Gooseneck: 120 mm (4.72") Microphone: Ø16 mm (Ø0.63")	Width: 155 mm (6.1") Gooseneck: 120 mm (4.72") Microphone: Ø17.8 mm (Ø0.7")	Width: 155 mm (6.1") Gooseneck: 120 mm (4.72") Microphone: Ø17.8 mm (Ø0.7")	Width: 155 mm (6.1"); Gooseneck: 120 mm (4.72") Microphone: Ø17.8 mm (Ø0.7") PS418S: Ø21 x 106 mm (Ø0.83" x 4.18")	Width: 155 mm (6.1"); Gooseneck: 120 mm (4.72") Microphone: Ø17.8 mm (Ø0.7") PS418D: H84 x W63 x D22.5 mm (H3.3" x W2.48" x D0.89")
Net Weight	Microphone: 65 g (2.3 oz)	Microphone: 65 g (2.3 oz)	Microphone: 65 g (2.3 oz)	Microphone: 65 g (2.3 oz) PS418S: 118 g (4.2 oz)	Microphone: 65 g (2.3 oz) PS418D: 245g (8.6 oz)
Accessories Furnished	S11 windscreen, belt clamp	S11 windscreen, belt clamp	S11 windscreen, belt clamp	S11 windscreen, belt clamp, PS418S preamp	S11 windscreen, belt clamp, 1.5V AA alkaline battery, PS418D preamp
Packaging	Colorful outer packaging	Colorful outer packaging	Colorful outer packaging	Colorful outer packaging	Colorful outer packaging

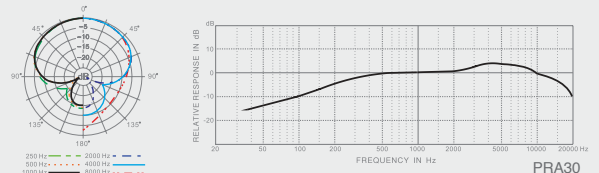
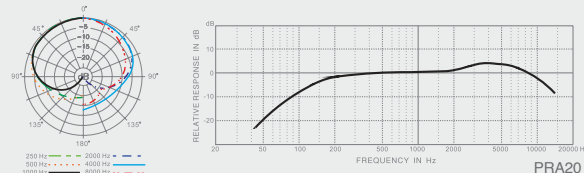



## E10A Headworn Condenser Microphone

### Vocals / Dancers / Drummers / Guitarists

The E10A is a condenser headworn miniature microphone designed for close-up applications where it always keeps the same distance between the mic and the sound source. The improved cable arrangement, flexible headband, and comfortable low-profile outline makes it perfect for long-term wear. It is ideally suited for sports, gyms, interviews, drama, speech, and musicians.

- Professional headworn vocal microphone
- Especially designed for hands-free microphone applications
- Low-profile design, with adjustable band to properly position the microphone
- E10ATQG is for use with wireless systems

E10ATQG TA4F connector for wireless systems  
 E10AXLR TA3F connector for PS418S preamp (phantom power only)  
 E10ADXLR TA3F connector for the PS418D preamp (either phantom power or battery)



## E10B Headworn Condenser Figure 8 Microphone

### Speech / Drama / Dance Coach

The E10B is a back electret figure 8 headworn condenser mini-microphone with greater intelligibility and newly designed wiring for a sleek look, making it perfect for active users to have a low-profile appearance and long-term wearing comfort. It is designed for dancers, coaches, dramatists and all vocals.

- Figure 8 directivity helps to eliminate ambient noise, giving better intelligibility
- High-quality headworn microphone for hands-free applications
- Low-profile design, with adjustable band to properly position the microphone
- E10B TQG is for wireless systems

E10BTQG TA4F for wireless systems  
 E10BXLRL TA3F connector for PS418S preamp (phantom power only)  
 E10BDXLRL TA3F connector for PS418D preamp (either phantom or battery)

### Specifications

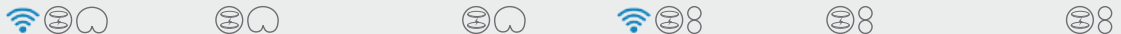

Model No.	E10ATQG	E10AXLR	E10ADXLR	E10BTQG	E10BXLRL	E10BDXLRL	
Type	Back electret, Ø9.7 mm (Ø0.38")	Back electret, Ø9.7 mm (Ø0.38")	Back electret, Ø9.7 mm (Ø0.38")	Back electret, Ø9.7 mm (Ø0.38")	Back electret, Ø9.7 mm (Ø0.38")	Back electret, Ø9.7 mm (Ø0.38")	
Polar Pattern	Cardioid	Cardioid	Cardioid	Figure 8, noise-canceling	Figure 8, noise-canceling	Figure 8, noise-canceling	
Frequency Response	50-15,000 Hz	50-15,000 Hz	50-15,000 Hz	50-15,000 Hz	50-15,000 Hz	50-15,000 Hz	
Low Frequency Filter	N/A	N/A	80Hz@12 dB/oct/(PS418D)	N/A	N/A	80Hz, 12 dB/oct/ (PS418D)	
Sensitivity	-36 dBV/Pa (15.8 mV)	-46 dBV/Pa (5 mV)	Phantom: -44 dB (6.31 mV) Battery: -45 dB (5.6 mV)	-33 dBV/Pa (22.4 mV)	-42 dBV/Pa (7.9 mV)	Phantom: -42 dBV/Pa (7.9 mV) Battery: -40 dBV/Pa (10 mV)	
Output Impedance	200 Ω	200 Ω	Phantom: 200 Ω Battery: 600 Ω	200 Ω	200 Ω	Phantom: 200 Ω Battery: 600 Ω	
Minimum Load Impedance	1,000 Ω	1,000 Ω	Phantom: 1,000 Ω Battery: 2,000 Ω	1,000 Ω	1,000 Ω	Phantom: 1,000 Ω Battery: 2,000 Ω	
S/N Ratio	N/A	72 dB	Phantom: 72 dB Battery: 73 dB	N/A	76 dB	71 dB	
Equivalent Output Noise	N/A	22 dB	Phantom: 22 dB Battery: 21 dB	N/A	18 dB	23 dB	
Max. SPL	N/A	145 dB SPL	Phantom: 134 dB SPL Battery: 128 dB SPL	N/A	141 dB SPL	Phantom: 137 dB SPL Battery: 127 dB SPL	
Dynamic Range	N/A	125 dB SPL	Phantom: 112 dB Battery: 107 dB	N/A	123 dB	Phantom: 114 dB Battery: 104 dB	
Power Requirements	1.5-9V DC	12-52V DC, 3.5 mA	Phantom: 12-52V DC, 3.5 mA Battery: 1.5VDC AA/UM3	1.5-9V DC	Phantom: 12-52V DC, 3.5 mA	Phantom: 12-52V DC, 3.5 mA Battery: 1.5VDC (AA)	
Finish	Black	Black	Black	Black	Black	Black	
Connector	TA4F, 1.5-meter cable	TA3F, 1.5-meter cable	TA3F, 1.5-meter cable	TA4F, 1.5-meter cable	TA3F, 1.5-meter cable	TA3F, 1.5-meter cable	
Dimensions	Width: 166 mm (6.5") Gooseneck: 100 mm (3.94") Microphone: Ø12.5 mm (Ø0.5")	Width: 166 mm (6.5"); Gooseneck: 100 mm (3.94") Microphone: Ø12.5 mm (Ø0.5") PS418S: Ø21 x 106 mm (Ø0.83" x 4.18")	Width: 166 mm (6.5") Gooseneck: 100 mm (3.94") Microphone: Ø12.5 mm (Ø0.5") PS418D: H84 x W63 x D22.5 mm (H3.3" x W2.48" x D0.89")	Width: 166 mm (6.5") Gooseneck: 100 mm (3.94") Microphone: Ø12.5 mm (Ø0.5")	Width: 166 mm (6.5") Gooseneck: 100 mm (3.94") Microphone: Ø12.5 mm (Ø0.5") PS418S: Ø21 x 106 mm (H3.3" x W2.48" x D0.89") (Ø0.83" x 4.18")	Width: 166 mm (6.5") Gooseneck: 100 mm (3.94") Microphone: Ø12.5 mm (Ø0.5") PS418D: H84 x W63 x D22.5 mm (H3.3" x W2.48" x D0.89")	Width: 166 mm (6.5") Gooseneck: 100 mm (3.94") Microphone: Ø12.5 mm (Ø0.5")
Net Weight	Microphone: 40 g (1.4 oz)	Microphone: 40 g (1.4 oz) PS418S: 118 g (4.2 oz)	Microphone: 40 g (1.4 oz) PS418D: 245 g (8.6 oz)	Microphone: 40 g (1.4 oz)	Microphone: 40 g (1.4 oz) PS418S: 118g (4.2 oz)	Microphone: 40g (1.4 oz) PS418D: 245g (8.6 oz)	
Accessories Furnished	S23 windscreen	S23 windscreen, S23 preamp, PS418S preamp	S23 windscreen, 1.5V AA alkaline battery, PS418D preamp	S23 windscreen	S23 windscreen, S23 preamp, PS418S preamp	S23 windscreen, S23 preamp, PS418D preamp	
Packaging	Colorful outer packaging	Colorful outer packaging	Colorful outer packaging	Colorful outer packaging	Colorful outer packaging	Colorful outer packaging	

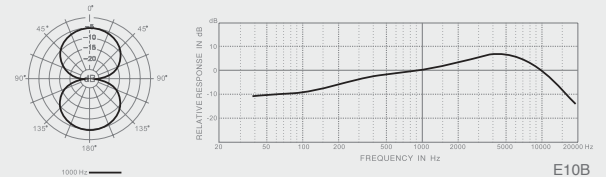
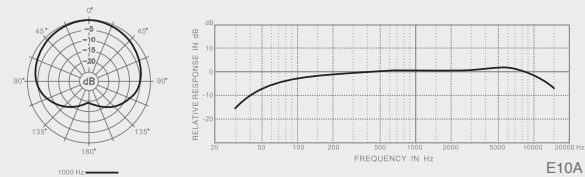



## E12A

### Miniature Omni Condenser Lavalier Microphone

TV / Broadcast / Speech / General Purpose

The E12A omni lavalier mini clip-on condenser microphone is ideal for inconspicuous recording. Its tailored frequency response gives accurate, intelligible speech recognition, making it well suited for the interview programs of TV and radio stations for recording where ambient noise is not an issue.

- Miniature shape
- Flat and wide frequency response
- Tailored frequency response that gives proper emphasis to speech intelligibility
- E12ATQG is for wireless systems

- E12ATQG TA4F connector for wireless system
- E12AXLR TA3F connector for PS418S preamp (phantom power only)
- E12ADXLR TA3F connector for PS418D preamp (either phantom power or battery)

## Specifications



Model No.	E12ATQG	E12AXLR	E12ADXLR
Type	Back electret, Ø4 mm (Ø0.16")	Back electret, Ø4 mm (Ø0.16")	Back electret, Ø4 mm (Ø0.16")
Polar Pattern	Omni	Omni	Omni
Frequency Response	20-20,000 Hz	20-20,000 Hz	20-20,000 Hz
Low Frequency Filter	N/A	N/A	80Hz, 12 dB / oct / (PS418D)
Sensitivity	-33 dBV/Pa (22.4 mV)	-42 dBV/Pa (7.9 mV)	Phantom: -42 dBV/Pa (7.9 mV) Battery: -47 dBV/Pa (4.5 mV)
Output Impedance	200 Ω	200 Ω	Phantom: 200 Ω      Battery: 600 Ω
Min. Load Impedance	1,000 Ω	1,000 Ω	Phantom: 1,000 Ω      Battery: 2,000 Ω
S/N Ratio	N/A	76 dB	Phantom: 76 dB      Battery: 74 dB
Equivalent Output Noise	N/A	18 dB	Phantom: 18 dB      Battery: 20 dB
Max. SPL	N/A	137 dB SPL	Phantom: 137 dB SPL      Battery: 129 dB SPL
Dynamic Range	N/A	119 dB	Phantom: 119 dB      Battery: 109 dB
Power Requirements	2.5-9V DC	12-52V DC, 3.5 mA	Phantom: 12-52V DC, 3.5 mA Battery: 1.5VDC AA/UM3
Finish	Black	Black	Black
Connector	TA4F, 1.5-meter cable	TA3F, 1.5-meter cable	TA3F, 1.5-meter cable
Dimensions	Microphone: 10.5 x 7 x 4 mm (0.41" x 0.28" x 0.6")	Microphone: 10.5 x 7 x 4 mm (0.41" x 0.28" x 0.6") PS418S: Ø21 x 106 mm (Ø0.83" x 4.18")	Microphone: 10.5 x 7 x 4 mm (0.41" x 0.28" x 0.6") PS418D: H84 x W63 x D22.5 mm (H3.3" x W2.48" x D0.89")
Net Weight	19 g (0.7 oz)	Microphone: 19 g (0.7 oz) PS418S: 118 g (4.2 oz)	Microphone: 19 g (0.67 oz) PS418D: 245 g (8.6 oz)
Accessories Furnished	S53 windscreen, clamp	S53 windscreen, clamp, PS418S preamp	S53 windscreen, clamp, 1.5V AA alkaline battery, PS418D preamp
Packaging	Colorful outer packaging	Colorful outer packaging	Colorful outer packaging

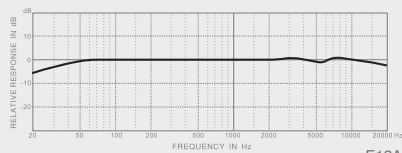
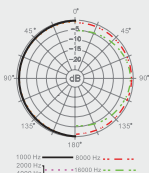



## WO518

### Miniature Omni Condenser Lavalier Microphone

TV Broadcasting / Speech / Cello / Double Bass / Eastern Strings

The WO518 is an omni lavalier clip-on condenser microphone with a frequency response tailored to give accurate, intelligible speech recognition. It is ideally suited for the interview programs of TV broadcasting and video production. The extended bass frequency range of this mic makes it the best choice for cello and double bass sound pick-up.

- Boosted wire mesh grille increases the HF response
- Wind screen foam to reduce those unwanted "pop" sounds
- Flat and wide frequency response, high SPL, high dynamic range, low distortion
- WO518TQG is for wireless systems

WO518TQG TA4F connector for wireless system  
 WO518XLR TA3F connector for PS418S preamp (phantom power only)  
 WO518DXLR TA3F connector for PS418D preamp (either phantom power or battery)



## WU518

### Miniature Cardioid Condenser Lavalier Microphone

Speech / Eastern String / General Purpose

The WU518 is a unidirectional electret lavalier condenser clip-on microphone for inconspicuous recording. The cardioid directivity suppresses the ambient sound, giving high gain before feedback, making this mic especially suitable for live performance sound reinforcement.

- Boosted wire mesh grille increases the HF response
- Built-in 1.5-meter (5') cable
- Phantom or battery power
- WU518TQG is for wireless systems

WU518TQG TA4F connector for wireless systems  
 WU518XLR TA3F connector for PS418S preamp (phantom power only)  
 WU518DXLR TA3F connector for PS418D preamp (either phantom power or battery)

### Specifications

Model No.	WO518TQG	WO518XLR	WO518DXLR	WU518TQG	WU518XLR	WU518DXLR
Element	Back electret, Ø6 mm (Ø0.24")	Back electret, Ø6 mm (Ø0.24")	Back electret, Ø6 mm (0.24")	Back electret, Ø6 mm (0.24")	Back electret, Ø6 mm (0.24")	Back electret, Ø6 mm (0.24")
Polar Pattern	Omnidirectional	Omnidirectional	Omnidirectional	Cardioid	Cardioid	Cardioid
Frequency response	20-20,000 Hz	20-20,000 Hz	20-20,000 Hz	60-15,000 HZ	60-15,000 HZ	60-15,000 HZ
Low Frequency Filter	N/A	N/A	80Hz@12 dB / oct / (PS418D)	N/A	N/A	80Hz@12 dB / oct / (PS418D)
Sensitivity	-32 dBV/Pa (25.1 mV)	-44 dBV/Pa (6.3 mV)	Phantom: -40 dBV/Pa (10 mV) Battery: -43 dBV/Pa (7.1 mV)	-33 dBV/Pa (22.4 mV)	-45 dBV/Pa (5.6 mV)	Phantom: -46 dBV/Pa (5 mV) Battery: -48 dBV/Pa (4 mV)
Output Impedance	200 Ω	200 Ω	Phantom: 200 Ω Battery: 600 Ω	200 Ω	200 Ω	Phantom: 200 Ω Battery: 600 Ω
Min. Load Impedance	1,000 Ω	1,000 Ω	Phantom: 1,000 Ω Battery: 2,000 Ω	1,000 Ω	1,000 Ω	Phantom: 1,000 Ω Battery: 2,000 Ω
S/N Ratio	N/A	72 dB	Phantom: 76 dB Battery: 75 dB	N/A	72 dB	Phantom: 70 dB Battery: 70 dB
Equivalent Output Noise	N/A	22 dB	Phantom: 18 dB Battery: 19 dB	N/A	22 dB	Phantom: 24 dB Battery: 24 dB
Max. SPL	N/A	132 dB SPL	Phantom: 130 dB SPL Battery: 126 dB SPL	N/A	133 dB	Phantom: 137 dB SPL Battery: 131 dB SPL
Dynamic Range	N/A	110 dB	Phantom: 112 dB Battery: 107 dB	N/A	111 dB	Phantom: 113 dB Battery: 107 dB
Power Requirements	1.5~9V DC	12~52V DC, 3.5 mA	Phantom: 12~52V DC, 3.5 mA Battery: 1.5VDC AA/UM3	1.5~9V DC	Phantom: 12~52V DC, 3.5 mA DC, 3.5 mA	Phantom: 12~52V DC, 3.5 mA DC, 3.5 mA
Finish	Black	Black	Black	Black	Black	Black
Connector	TA4F, 1.5-meter cable	TA3F, 1.5-meter cable	TA3F, 1.5-meter cable	TA4F, 1.5-meter cable	TA3F, 1.5-meter cable	TA3F, 1.5-meter cable
Dimensions	Microphone: Ø8 x 12 mm (Ø0.31" x 0.47") PS418S: Ø21 x 106 mm (Ø0.83" x 4.18")	Microphone: Ø8 x 12 mm (Ø0.31" x 0.47") PS418S: Ø21 x 106 mm (Ø0.83" x 4.18")	Microphone: Ø8 x 12 mm (Ø0.31" x 0.47") PS418D: H84 x W63 x D22.5 mm (H3.3" x W2.48" x D0.89")	Microphone: Ø8 x 12 mm (Ø0.31" x 0.47")	Microphone: Ø8 x 12 mm (Ø0.31" x 0.47") PS418S: Ø21 x 106 mm (Ø0.83" x 4.18")	Microphone: Ø8 x 12 mm (Ø0.31" x 0.47") PS418D: H84 x W63 x D22.5 mm (H3.3" x W2.48" x D0.89")
Net Weight	Microphone: 20 g (0.7 oz)	Microphone: 20 g (0.7 oz) PS418S: 118 g (4.2 oz)	Microphone: 20 g (0.7 oz) PS418D: 245 g (8.6 oz)	Microphone: 20 g (0.7 oz)	Microphone: 20 g (0.7 oz) PS418S: 118 g (4.2 oz)	Microphone: 20 g (0.7 oz) PS418D: 245 g (8.6 oz)
Accessories Furnished	S12 HF boost windscreen, S13 windscreen, clip	S12 HF boost windscreen, S13 windscreen, clip, PS418S preamp	S12 HF boost windscreen, S13 windscreen, clip, 1.5V AA alkaline battery, PS418D preamp	S12 HF boost windscreen, S13 windscreen, clip	S12 HF boost windscreen, S13 windscreen, clip, PS418S preamp	S12 HF boost windscreen, S13 windscreen, clip, 1.5V AA alkaline battery, PS418D preamp
Packaging	Colorful outer packaging	Colorful outer packaging	Colorful outer packaging	Colorful outer packaging	Colorful outer packaging	Colorful outer packaging

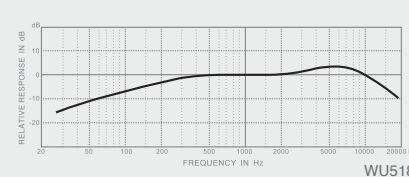
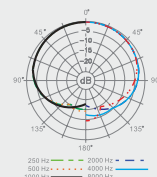
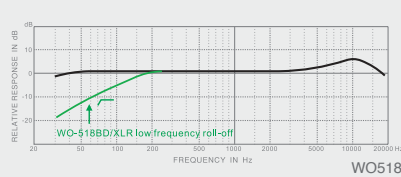
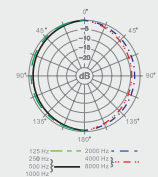



# **Instrument Microphones & Drum Sets**

- PRA383TQG TA4F connector for wireless system with a 1.5-meter cable
- PRA383XLR TA3F connector for PS418S preamp (phantom power only)
- PRA383DXLR TA3F connector for PS418D preamp (either phantom power or battery)



## PRA383 Clip-On Gooseneck Microphone

### Strings / Winds / Percussion / Brass

The PRA383 is ideal for saxophones, woods, eastern and western strings and percussion because of its high SPL capability and flat response. The PRA383 is easy to clip onto various instruments and simple to adjust by bending the short gooseneck for the sweet spot. A good choice for mid-high frequency range instrument sound pick-up, the PRA383 is a necessity for live sound and a studio recording device.

- Gooseneck with clip can be installed on brass and string instruments easily
- Cardioid polar pattern suppresses sound from rear and sides
- Built-in 1.5M cable for connecting to preamplifier device

### Specifications



Model No.	PRA383TQG	PRA383XLR	PRA383DXLR
Type	Back electret, Ø9.7 mm (Ø0.38")	Back electret, Ø9.7 mm (Ø0.38")	Back electret, Ø9.7 mm (Ø0.38")
Polar Pattern	Cardioid	Cardioid	Cardioid
Frequency Response	40-18,000 Hz	40-18,000 Hz	40-18,000 Hz
Low Frequency Filter	N/A	N/A	80 Hz @ 12 dB/oct (PS418D)
Sensitivity	-44 dBV/Pa (6.3 mV)	-42 dB/Pa (7.8 mV)	Phantom Power: -44 dBV/Pa (6.3 mV) Pa (5.6 mV) Battery: -45 dB/Pa (5.6 mV)
Output Impedance	200 Ω	200 Ω	Phantom power: 200 Ω Battery: 600 Ω
Min. Load Impedance	1,000 Ω	1,000 Ω	Phantom power: 1,000 Ω Battery: 2,000 Ω
S/N Ratio	N/A	71 dB	Phantom power: 72 dB Battery: 73 dB
Equivalent Output Noise	N/A	23 dB	Phantom power: 22 dB Battery: 21dB
Max. SPL	N/A	137 dB SPL	Phantom Power: 129 dB SPL 139 dB SPL
Dynamic Range	N/A	114 dB	Phantom Power: 117 dB Battery: 108 dB
Power Requirements	3-12V DC	12-52V DC, 3.5 mA	12-52V DC, 3.5 mA
Finish	Black	Black	Black
Connector	TA4F, 1.5M cable	TA3F, 1.5M cable	TA3F, 1.5M cable
Dimensions	Microphone: Ø12.5 x 27 mm (Ø0.5" x 1.1")	Microphone: Ø12.5 x 27 mm (Ø0.5" x 1.1") PS418S: Ø21 x 106 mm (Ø0.83" x 4.18")	Microphone: Ø12.5 x 27 mm (Ø0.5" x 1.1") PS418D: H84 x W63 x D22.5 mm (H3.3" x W2.48" x D0.89")
Net Weight	160 g (5.64 oz)	Microphone: 160 g (5.64 oz) PS418S: 118 g (4.2 oz)	Microphone: 160 g (5.64 oz) PS418D: 245 g (9.9 oz)
Accessories Furnished	N/A	PS418S preamp	PS418D preamp, 1.5V AA alkaline battery
Packaging	A1 carrying case, Colorful outer sleeve		

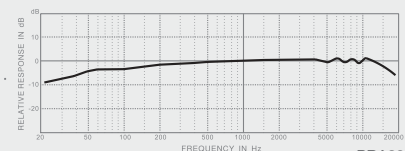
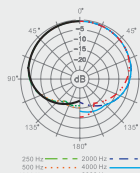

PRA383



E101TQG TA4F connector for wireless system  
 E101DXLR TA3F connector for PS418D pre amp (either phantom power or battery)



## E101 Guitar Microphone

### Classical Guitar / Acoustic Guitar

The E101 electret condenser microphone is designed for instrument and vocal pick-up. Matched with purpose designed guitar clip to pick up acoustic guitar with natural sound texture.

Its cardioid polar pattern can enhance on axis signal and reject sound from the rear. It is suitable for live vocal, drum, and brass sound pick up applications. Mounting accessories are included so that the microphone can be mounted for various uses such as drums, winds, speech, or singing. The E101 is an easy solution for the professional.

- Wide and uniform frequency response
- Background noise suppressed, high gain before feedback
- E101DXLR includes PS418D preamplifier with 80 Hz HPF
- Built-in 1.5M cable

### Specifications



Model No.	E101TQG	E101DXLR
Type	Back electret, Ø9.7 mm (Ø0.38")	Back electret, Ø9.7 mm (Ø0.38")
Polar Pattern	Cardioid	Cardioid
Frequency Response	40-18,000 Hz	40-18,000 Hz
Low Frequency Filter	N/A	80 Hz, 12 dB/oct (PS418D)
Sensitivity	-44 dBV/Pa (6.3 mV)	Phantom: -44 dBV/ Pa (6.3mV) Battery: -45 dBV/ Pa (5.6mV)
Output Impedance	200 Ω	Phantom: 200 Ω Battery: 600 Ω
Min. Load Impedance	1,000 Ω	Phantom: 1,000 Ω Battery: 2,000 Ω
S/N Ratio	N/A	69 dB
Equivalent Output Noise	N/A	25 dB
Max.SPL	N/A	Phantom: 139 dB SPL Battery: 129 dB SPL
Dynamic Range	N/A	Phantom: 114 dB Battery: 104 dB
Power Requirements	3-12V DC	12-52V DC, 4mA
Finish	Black	Black
Connector	TA4F, 1.5M cable	TA3F, 1.5M cable
Dimensions	Ø12.5 mm (Ø0.5")	Microphone: Ø12.5 mm (Ø0.5") PS418D: H84 x W63 x D22.5 mm (H3.3" x W2.48" x D0.89")
Net Weight	30 g (1.06 oz)	Microphone: 30 g (1.06 oz) PS418D: 245 g (9.9 oz)
Accessories Furnished	All models include: spring clip, guitar clip, universal clamp, table clamp, necktie clip, S06 windscreen, E101DXLR equipped with PS418D and 1.5V AA alkaline battery	
Packaging	Colorful outer packaging	

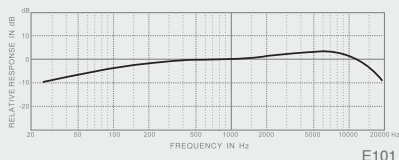
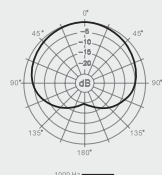

E101



## D112 Harmonica Microphone

### Harmonica

The D112 is a new Hi-Z blues harmonica microphone with unique curves to fit the hands when playing. It has a level knob for the player to adjust the sound to a suitable level. Permanently attached cable with 1/4" output connector can directly plug into the guitar amplifier or other high impedance devices.

- Hi-Z matched with harmonica can directly plug into the guitar amplifier
- Warm and full sound
- Body curves fit the hands when playing
- 6.3 mm TS output connector
- Permanent 6 mm x 3M attached shield cable
- Level knob for player to adjust suitable sound level, center detent included

### Specifications



Type	Dynamic
Polar Pattern	Omni
Frequency Response	100-6,000 Hz
Sensitivity	-50 dBV/Pa (3.2 mV)
Output Impedance	10 kΩ
Min. Load Impedance	100 kΩ
Max.SPL	140 dB SPL
Finish	Titanium blue
Connector	6.3 mm (1/4"), 3M cable
Dimensions	Ø63 x 80 mm (Ø2.48" x 3.15")
Net Weight	650 g (22.93 oz)
Optional Accessories	CP838 impedance converter
Packaging	Colorful outer packaging

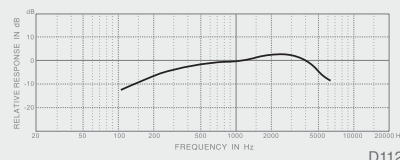

D112



## PRO218A

### Kick Drum Microphone

Kick Drum / High Dynamic LF Instrument

The PRO218A supercardioid dynamic microphone is designed for bass drum, with tailored low frequency response and high SPL capacity up to 174 dB SPL. The PRO218A is best for bass drum or other bass instruments.

- Tailored low frequency response
- Tender and stout in bass
- High gain before feedback
- High dynamic range
- The DRKB5C2MKII includes 1 PRO218A

### Specifications

Type	Dynamic
Polar Pattern	Supercardioid
Frequency Response	20-10,000 Hz
Sensitivity	-64 dBV/Pa (0.6 mV)
Output Impedance	45 Ω
Min. Load Impedance	150 Ω
Max. SPL	174 dB SPL
Finish	Titanium blue
Connector	XLR3M
Dimensions	Ø58 × 140 mm (Ø2.28" × 5.51")
Net Weight	350 g (12.3 oz)
Accessories Furnished	HM27S clip with screw knob, YA2 threaded adapter, Pouch
Packaging	Colorful outer packaging

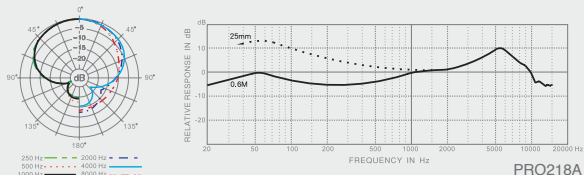

## PRO228A

### Tom-Tom Microphone

Tom-Tom / Snare / Percussion / Brass

The PRO228A is specially designed for tom-tom with permanent attached microphone clip and has a high SPL capacity, up to 150 dB SPL. It is also suitable for brass.

- Flat mid-low frequency band, wide frequency response
- High SPL capacity, high dynamic range, low distortion
- Best for instruments with mid-low frequency
- The DRKB5C2MKII includes 3 PRO228As

### Specifications

Type	Dynamic
Polar Pattern	Supercardioid
Frequency Response	50-16,000 Hz
Sensitivity	-54 dBV/Pa (2.0 mV)
Output Impedance	300 Ω
Min. Load Impedance	300 Ω
Max. SPL	150 dB SPL
Finish	Titanium blue
Connector	XLR3M
Dimensions	Ø43 × 123 mm (Ø1.69" × 4.84")
Net Weight	180 g (6.52 oz)
Accessories Furnished	Fixed clip with screw knob, YA2 threaded adapter, Pouch
Packaging	Colorful outer packaging

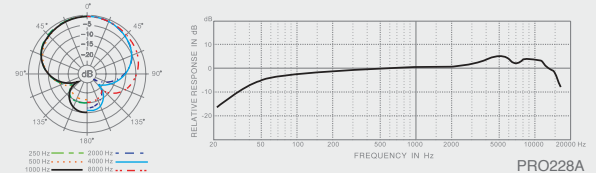



## PRO268B

### Overhead Microphone

Overhead / Strings / Brass / Mid-High Frequency Instruments

The PRO268B is a back electret condenser microphone for drum set overhead. It is suitable for mid to high frequency instruments. It also features an inter-changeable capsule design.

- Back electret condenser microphone
- Flat low frequency band, mid-high frequency boost response
- High SPL capacity
- Wide dynamic range and low distortion
- High gain before feedback
- Dedicated design for mid-high range instruments
- DRKB5C2MKII includes 2 PRO268Bs

### Specifications



Type	Back electret, Ø16 mm (Ø0.63")
Polar Pattern	Cardioid
Frequency Response	40-20,000 Hz
Low Frequency Filter	80 Hz, 12 dB/oct
Pad	-10 dB
Sensitivity	-43 dBV/Pa (7.1 mV)
Output Impedance	200 Ω
Min. Load Impedance	1,000 Ω
S/N Ratio	69 dB
Equivalent Noise SPL	25 dB
Max.SPL	140 dB SPL
Dynamic Range	115 dB
Power Requirements	12-52V DC, 2 mA
Finish	Titanium blue
Connector	XLR3M
Dimensions	Ø29 x 240 mm (Ø1.14" x 9.45")
Net Weight	270 g (9.5 oz)
Accessories Furnished	HM30S clip with screw knob, YA2 threaded adapter, S20 windscreen, Pouch
Packaging	Colorful outer packaging

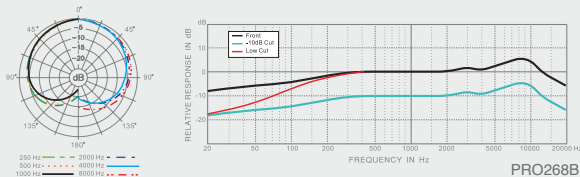

## PRA288A

### Snare Noise Microphone

Snare Drum / Clarinet / Suona

The PRA288A is specially designed for snare noise pick-up. Its tailored frequency response, with low end roll off and slight high end roll off, makes it perfect for mid-high frequency instruments.

- Tailored frequency response for snare drum
- Cardioid directivity ensure high gain before feedback, suppressed ambient noise
- Mini shape, easy to install and hardly noticeable
- Sturdy metal structure
- DRKB5C2MKII includes one PRA288A

### Specifications



Type	Dynamic
Polar Pattern	Cardioid
Frequency Response	80-20,000 Hz
Sensitivity	-56 dBV/Pa (1.6 mV)
Output Impedance	500 Ω
Min. Load Impedance	500 Ω
Max.SPL	140 dB SPL
Finish	Titanium blue
Connector	XLR3M
Dimensions	Ø29 x 107 mm (Ø1.14" x 4.21")
Net Weight	110 g (3.9 oz)
Accessories Furnished	HM10S clip with screw knob, YA2 threaded adapter, Pouch
Packaging	Colorful outer packaging

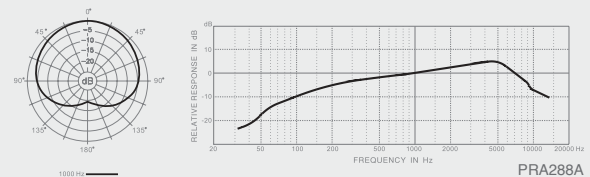



## D10B Instrument Microphone

**Strings / Brass / Percussion / Acoustic Guitar / Guitar Amplifier**

The D10B is a dynamic supercardioid microphone designed for musical instrument live sound and recording applications. The D10B exhibits wide and flat frequency response with its high SPL capacity and is not easy to distort. Built-in hum-bucking circuit effectively reduces the interference from electromagnetic waves and other devices.

The shock mount within the D10B also greatly reduces mechanical vibration and stage noises. All metal construction with a strengthened grille makes the D10B very durable for stage. Besides, all the accessories like mic clip, drum clamp, and pouch are included to fulfill every application. It is a high value product.

- Dedicated design for mid-high range instruments
- Supercardioid polar pattern, high gain before feedback
- High SPL capability
- Hum-bucking coil to reduce interference by power line and the other device
- Value Pack includes microphone clip, shock mount, drum clamp and pouch

### Specifications

Type	Dynamic
Polar Pattern	Supercardioid
Frequency Response	50-18,000 Hz
Sensitivity	-54 dBV/Pa (2.0 mV)
Output Impedance	200 Ω
Min. Load Impedance	200 Ω
Max.SPL	135 dB
Finish	Titanium grey
Connector	XLR3M
Dimensions	Ø42.5 × 144.0 mm (Ø1.67" × 5.67")
Net Weight	220 g (7.8 oz)
Accessories Furnished	HM38S clip with screw knob, HM54 shock mount, HM25 drum clamp, YA2 threaded adapter, Pouch
Packaging	Colorful outer packaging

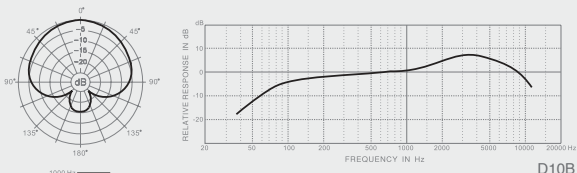

## E124D Instrument Microphone

**Acoustic Guitar / Eastern and Western Strings / Brass / Piano / Percussion / Vocal**

The E124D is a unidirectional electret condenser microphone with tailored frequency response to meet the instrument demand for professional musicians and sound engineers in both live performance and sound recording applications. Its smooth, flat frequency response is free of either a presence peak or a low-frequency roll-off, and it is powered by both 1.5V battery or phantom power, making it a perfect choice for musical instrument pick up, reinforcement systems, studio recording, and TV interviews.

- Best for reproduction of strings, brass and cymbals
- Powered by both 1.5V AA battery or phantom power
- Built-in low cut filter
- Built-in shock mount structure reduces vibrating noise
- Prosumer product
- 6-meter microphone cable is included

E124D / P 6-meter XLR3F-6.3 mm TS mic cable  
E124D / X 6-meter XLR3F-XLR3M mic cable

### Specifications

Type	Back electret, Ø9.7 mm (Ø0.38")	
Polar Pattern	Cardioid	
Frequency Response	40-18,000 Hz	
Low Frequency Filter	100 Hz, internal	
Sensitivity	-50 dBV/Pa (3.2 mV)	
Output Impedance	600 Ω	
Min. Load Impedance	800 Ω	
S/N Ratio	68 dB	
Equivalent Output Noise	26 dB	
Max.SPL	Phantom: 131 dB SPL	Battery: 127 dB SPL
Dynamic Range	Phantom: 105 dB	Battery: 101 dB
Power Requirements	Phantom: 12-52V DC, 2mA	Battery: 1.5V AA/UM3
Finish	Black	
Connector	XLR3M	
Dimensions	Ø31 (Ø24) × 205 mm, Ø1.22" (Ø0.94") × 8.07"	
Net Weight	300 g (10.6 oz)	
Accessories Furnished	6-meter microphone cable with, XLR3F-XLR3M or XLR3F-1/4" connectors, HM38S clip with screw knob, YA2 threaded adapter, S09 windscreen, 1.5V AA alkaline battery, pouch	
Optional Accessories	HM32 shock mount	
Packaging	Colorful outer packaging	

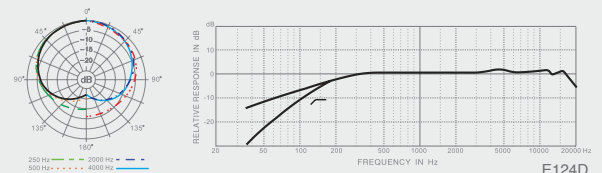



## E100

### Boundary Kick Drum Mic

#### Kick Drum / High SPL Bass Section

Low profile boundary mic with built-in electronics can be easily placed on a pillow or other surface in a kick drum for excellent attack and bass punch. Very high SPL ability and lower open circuit sensitivity matches Kick drum performance characteristics without overloading the mic amplifier in a mixer. The E100 also comes with a fixed installed 1.5-meter cable.

- Cardioid directivity
- High SPL ability
- Powerful low frequency band, no coloration
- Built-in preamplifier circuitry
- Built-in fixed 1.5-meter cable

#### Specifications



Type	Back electret, Ø14 mm (Ø0.55")
Polar Pattern	Cardioid
Frequency Response	30-18,000 Hz
Sensitivity	-60 dBV/Pa (1 mV)
Output Impedance	600 Ω
Min. Load Impedance	2,000 Ω
S/N Ratio	70 dB
Equivalent Output Noise	24 dB
Max.SPL	149 dB SPL
Dynamic Range	125 dB
Power Requirements	12-52V DC, 4 mA
Finish	Black
Connector	XLR3M
Dimensions	Ø85 x 20.5 mm (Ø3.35" x 0.81")
Net Weight	270 g (9.5 oz)
Accessories Furnished	Pouch
Packaging	Colorful outer packaging

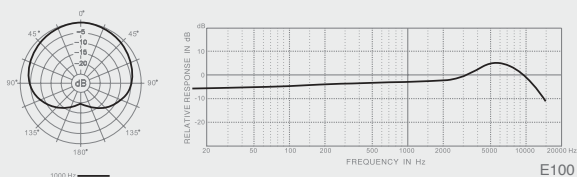

## E102

### Instrument Microphone

#### Piano / Percussion / Strings / Brass

Small diaphragm electret condenser is suitable for high frequency signal pickup. It's especially suitable for overheads, cymbals in a drum set, or mid-high frequency range instruments.

- Good mid-high frequency response
- High SPL, high dynamic range, low distortion
- Delicately high frequency, bright mid range

#### Specifications



Type	Back electret, Ø9.7 mm (Ø0.38")
Polar Pattern	Cardioid
Frequency Response	50-16,000 Hz
Sensitivity	-43 dBV/Pa (7.1 mV)
Output Impedance	200 Ω
Min. Load Impedance	1,000 Ω
S/N Ratio	75 dB
Equivalent Output Noise	19 dB
Max.SPL	149 dB SPL
Dynamic Range	130 dB
Power Requirements	12-52V DC, 3 mA
Finish	Black
Connector	XLR3M
Dimensions	Ø21 x 200 mm (Ø0.83" x 7.90")
Net Weight	140 g (5.00 oz)
Accessories Furnished	S27 windscreen, HM10S clip with screw knob, YA2 threaded adapter, Pouch
Packaging	Colorful outer packaging

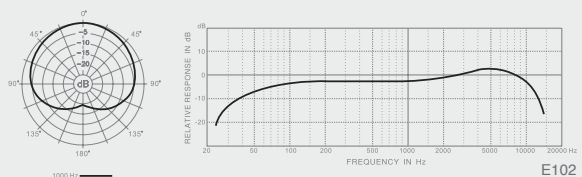



## HO8

### Overhead / Vocal Microphone

Over Head / Vocal / Guitar / String / Brass / Drums

The HO8 is a 19 mm back electret condenser studio microphone with flat and uniform frequency response, high SPL capacity, high dynamic range, low distortion, high gain before feedback, making it not only suitable for overheads, but also perfect for vocals.

- For studio and live use
- Ø19 mm large diaphragm condenser microphone
- Tailored mid-high frequency for cymbals and vocal
- Flat and wide frequency response with a little boost in mid-high range
- High SPL capacity, high dynamic range, low distortion, high gain before feedback
- DRKF5H3 includes 2 HO8s

### Specifications



Type	Back electret, Ø14 mm (Ø0.75")
Polar Pattern	Supercardioid
Frequency Response	40-18,000 Hz
Sensitivity	-39 dBV/Pa (11.2 mV)
Output Impedance	200 Ω
Min. Load Impedance	1,000 Ω
S/N Ratio	74 dB
Equivalent Output Noise	20 dB
Max.SPL	136 dB SPL
Dynamic Range	116 dB
Power Requirements	12-52V DC, 3 mA
Finish	Grey
Connector	XLR3M
Dimensions	Ø54 x 170 mm (Ø2.13" x 6.69")
Net Weight	320 g (11.3 oz)
Accessories Furnished	H6A stand mount, YA2 threaded adapter, screw in nut, pouch
Optional Accessories	HM26C shock mount
Packaging	Colorful outer packaging

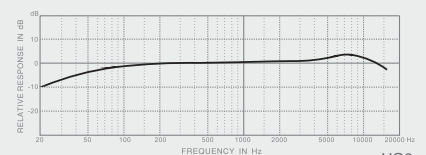
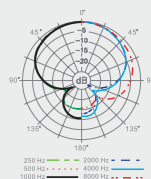

HO8





## FK2

### Kick Drum Microphone

Kick Drum / Bass Drum / Onidaiko / High Dynamic Low Frequency Instrument

The FK2 is a dynamic microphone with high SPL capacity and cardioid polar pattern. It is best for low frequency signal pickup, especially for kick drum, or low frequency musical instruments. It is integrated with a mic clip.

- Tailored low frequency response
- Soft bass with power
- High gain before feedback
- DRKF5H3 includes one FK2

#### Specifications



Type	Dynamic
Polar Pattern	Supercardioid
Frequency Response	30-10,000 Hz
Sensitivity	-62 dBV/Pa (0.8 mV)
Output Impedance	200 Ω
Min. Load Impedance	200 Ω
Max.SPL	147 dB SPL
Finish	Grey
Connector	XLR3M
Dimensions	Ø54.5 × 116.5 mm (Ø2.15" × 4.59")
Net Weight	210 g (7.4 oz)
Accessories Furnished	Fixed clip with screw knob, YA2 threaded adapter, Pouch
Packaging	Colorful outer packaging

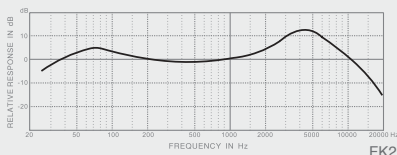
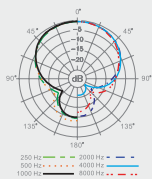

## FT4

### Tom-Tom Microphone

Tom-Tom / Brass

The FT4 dynamic microphone is specially designed for tom-tom with attached microphone clip. Its high SPL capacity, high dynamic range and low distortion make it perfect for mid-low frequency instruments.

- Tailored mid-low frequency response
- High SPL capacity
- High dynamic range, low distortion
- DRKF5H3 includes 3 FT4s

#### Specifications



Type	Dynamic
Polar Pattern	Supercardioid
Frequency Response	20-12,500 Hz
Sensitivity	-55 dBV/Pa (1.8 mV)
Output Impedance	200 Ω
Min. Load Impedance	200 Ω
Max.SPL	150 dB SPL
Finish	Grey
Connector	XLR3M
Dimensions	Ø47 × 104.5 mm (Ø1.85" × 4.12")
Net Weight	130 g (4.6 oz)
Accessories Furnished	Fixed clip with screw knob, YA2 threaded adapter, Pouch
Packaging	Colorful outer packaging

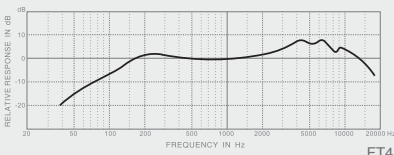
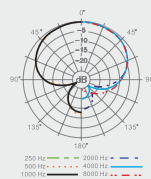

## FS6

### Snare Drum Microphone

Snare / Brass / Winds

The FS6 is specially designed for snare drum with fixed microphone clip. Its high SPL capacity, high dynamic range and low distortion make it perfect for snare, brass and winds.

- Tailored frequency response for snare drum
- High gain before feedback
- DRKF5H3 includes one FS6

#### Specifications



Type	Dynamic
Polar Pattern	Supercardioid
Frequency Response	50-16,000 Hz
Sensitivity	-55 dBV/Pa (1.8 mV)
Output Impedance	200 Ω
Min. Load Impedance	200 Ω
Max.SPL	140 dB SPL
Finish	Grey
Connector	XLR3M
Dimensions	Ø47 × 104.5 mm (Ø1.85" × 4.12")
Net Weight	130 g (4.6 oz)
Accessories Furnished	Fixed clip with screw knob, YA2 threaded adapter, Pouch
Packaging	Colorful outer packaging

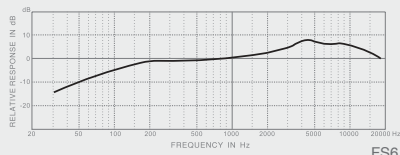
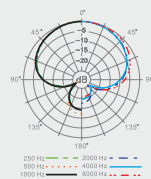



## HI10

### Hi-Hat Microphone

Hi-Hat / Cymbals / Guitar / Western & Eastern Strings

The HI10 is an integrated electronics back electret condenser small diaphragm pencil style microphone with cardioid directivity and tailored for cymbals and high frequency instruments. It provides bright, clear tone and cardioid directivity for high gain before feedback.

- Wide frequency response
- High sensitivity, low distortion
- High gain before feedback
- Pencil style condenser microphone
- Dedicated design for hi-hat and cymbals
- DRKF5H3 includes one HI10

#### Specifications



Type	Back electret, Ø14 mm (Ø0.55")
Polar Pattern	Cardioid
Frequency Response	50-18,000 Hz
Sensitivity	-38 dBV/Pa (12.6 mV)
Output Impedance	200 Ω
Min. Load Impedance	1,000 Ω
S/N Ratio	69 dB
Equivalent Output Noise	25 dB
Max.SPL	134 dB SPL
Dynamic Range	109 dB
Power Requirements	12-52V DC, 5 mA
Finish	Grey
Connector	XLR3M
Dimensions	Ø21 × 94 mm (Ø0.83" × 3.7")
Net Weight	120 g (4.2 oz)
Accessories Furnished	S20 windscreen, HM10S clip with screw knob, YA2 threaded adapter, Pouch
Packaging	Colorful outer packaging

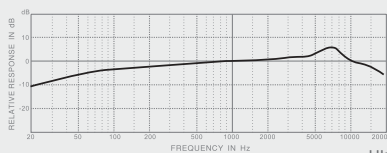

HI10



## E109

### Instrument Microphone

Hi-Hat / Cymbals / Guitar / Western & Eastern Strings / Brass

The E109 is an integrated electronics 16 mm back electret condenser microphone with interchangeable capsules, flat and uniform frequency response, specific high frequency band elevation, making it perfect for hi-hat, cymbals, guitar, violin, and high frequency instruments.

- High sensitivity for live performance
- High dynamic range
- Wide and uniform frequency response
- Uniform cardioid polar pattern
- Interchangeable capsule: the Supercardioid and Omni capsule are optional. Cardioid capsule is included
- DRK681 includes 3 E109s

#### Specifications



Type	Back electret, Ø16 mm (Ø0.63")
Polar Pattern	Cardioid
Frequency Response	40-20,000 Hz
Sensitivity	-43 dBV/Pa (7.1 mV)
Output Impedance	200 Ω
Min. Load Impedance	1,000 Ω
S/N Ratio	72 dB
Equivalent Output Noise	22 dB
Max.SPL	137 dB SPL
Dynamic Range	115 dB
Power Requirements	12-52V DC, 3.5 mA
Finish	Black
Connector	XLR3M
Dimensions	Ø20 × 112 mm (Ø0.79" × 4.41")
Net Weight	120 g (4.2 oz)
Accessories Furnished	S20 windscreen, HM10S clip with screw knob, YA2 threaded adapter, Pouch
Packaging	Colorful outer packaging

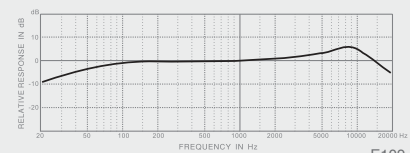
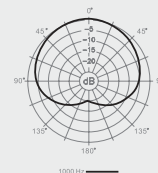

E109



## PRA628MKII

### Instrument Dynamic Microphone

Guitar Amp Pick Up / Bass Amp Pick Up / Speaker Pick Up

The PRA628MKII is an optimized model of the PRA628. With extended frequency response, deeper to the lower bottom range, higher SPL capacity, supercardioid directivity, high gain before feedback, and flat pop screen design, it is suitable for guitar, bass amplifier pick up or instrument reinforcement.

- High dynamic range and extended frequency response
- High SPL up to 150 dB SPL
- Flat pop screen design, closer to the sound source
- Universal clamp and mic clip included
- Tailored frequency response to reproduce the instrument natural sound
- Sturdy metal body

### Specifications

Type	Dynamic
Polar Pattern	Supercardioid
Frequency Response	80-18,000 Hz
Sensitivity	-55 dBV/Pa (1.8 mV)
Output Impedance	200 Ω
Max.SPL	150 dB SPL
Finish	Black
Connector	XLR3M
Dimensions	Ø60 x 127 x 36 mm, Ø2.36" x 5" x 1.42"
Net Weight	168 g (5.9 oz)
Accessories Furnished	HM12DA gooseneck clamp, HM10 mic clip, Pouch
Packaging	Colorful outer packaging

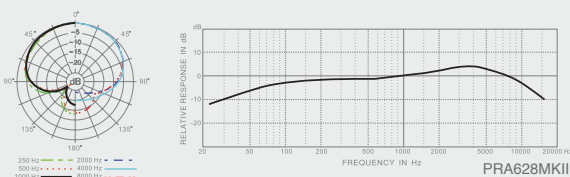

## PRA638

### Instrument Condenser Microphone

Brass / Piano / Acoustic Guitar / Strings

The PRA638 is a general purpose instrument condenser microphone with flat pop screen for closer to the sound source, and its cardioid polar pattern, high gain before feedback, extended frequency response make it perfect for general instrument reinforcement and recording.

- Flat pop screen for closer to the sound source
- Universal clamp and mic clip included
- 16 mm back electret condenser capsule
- Tailored frequency response to reproduce the instrument natural sound
- Sturdy metal body

### Specifications

Type	Back electret, Ø16 mm (Ø0.63")
Polar Pattern	Cardioid
Frequency Response	50-20,000 Hz
Sensitivity	-42 dBV/Pa (7.9 mV)
Output Impedance	200 Ω
Min. Load Impedance	1,000 Ω
S/N Ratio	70 dB
Equivalent Output Noise	24 dB
Max.SPL	146 dB SPL
Dynamic Range	122 dB
Power Requirements	12-52V DC, 3.5 mA
Finish	Black
Connector	XLR3M
Dimensions	Ø60 x 130 x 35 mm, Ø2.36" x 5.12" x 1.38"
Net Weight	190 g (6.7 oz)
Accessories Furnished	HM12DA gooseneck clamp, HM10 mic clip, Pouch
Packaging	Colorful outer packaging

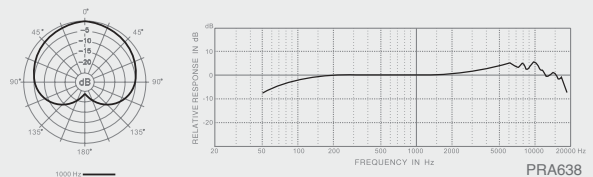



## PRA218A

### Kick Drum Microphone

**Bass Drum / Kick Drum / High Dynamic Range LF Instrument**

The PRA218A is specially designed for kick drum with fulfill warm sound and high SPL capability, making it suitable for other bass band or high SPL instruments. The PRA218A is attached with permanently microphone clip

- Specially designed for kick drum and bass drum
- High SPL capacity up to 134 dB
- Sturdy metal body
- Durable, reliable professional performance
- High energy neodymium magnet increase the output level
- DRKA5C2 includes one PRA218A
- DRKA3C2 includes one PRA218A

### Specifications



Type	Dynamic
Polar Pattern	Supercardioid
Frequency Response	20-12,500 Hz
Sensitivity	-53 dBV/Pa (2.2 mV)
Output Impedance	500 Ω
Min. Load Impedance	500 Ω
Max.SPL	134 dB SPL
Finish	Black
Connector	XLR3M
Dimensions	Ø43 x 120 mm
Net Weight	210 g (7.4 oz)
Accessories Furnished	Fixed clip with screw knob, YA2 threaded adapter, Pouch
Packaging	Colorful outer packaging

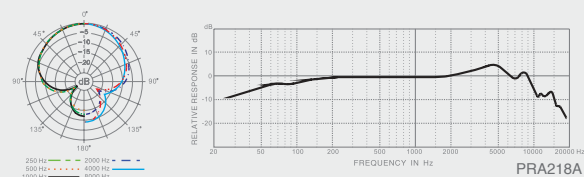

## PRA218B

### Kick Drum Microphone

**Kick Drum / Bass Drum / High SPL Instrument**

The PRA218B is specially designed for kick drum with fulfill warm sound and high SPL capability making it suitable for other bass band or high SPL instruments.

- Special designed for kick drum and bass drum
- High SPL capacity up to 148 dB
- Sturdy metal body
- Durable, reliable professional performance
- High energy neodymium magnet increases the output level
- DRKK5C2 includes one PRA218B

### Specifications



Type	Dynamic
Polar Pattern	Supercardioid
Frequency Response	30-10,000 Hz
Sensitivity	-61 dBV/Pa (0.9 mV)
Output Impedance	200 Ω
Min. Load Impedance	200 Ω
Max.SPL	148 dB SPL
Finish	Black
Connector	XLR3M
Dimensions	Ø58 x 140 mm, Ø2.28" x 5.51"
Net Weight	375 g (13.2 oz)
Accessories Furnished	HM27S clip with screw knob, YA2 threaded adapter, Screw in nut, Pouch
Packaging	Colorful outer packaging

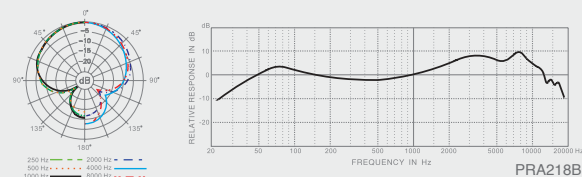



## PRA228A

### Tom-Tom Microphone

Tom-Tom / Snare / Strings / Guitar

The PRA228A is an especially fine tuned dynamic microphone for snare, tom-tom, floor tom and guitar with attached microphone clip.

- Special designed for snare, tom-tom and guitar
- Sturdy metal body
- Durable, reliable professional performance
- High energy neodymium magnet increases the output level
- DRKA3C2 includes 2 PRA228As
- DRKA5C2 includes 4 PRA228As

### Specifications

Type	Dynamic microphone
Polar Pattern	Supercardioid
Frequency Response	50-16,000 Hz
Sensitivity	-53 dBV/Pa (2.2 mV)
Output Impedance	500 Ω
Min. Load Impedance	500 Ω
Max. SPL	134 dB SPL
Finish	Black
Connector	XLR3M
Dimensions	Ø42 × 110 mm, Ø1.65" × 4.33"
Net Weight	185 g (6.5 oz)
Accessories Furnished	Fixed clip with screw knob, YA2 threaded adapter, Pouch
Packaging	Colorful outer packaging

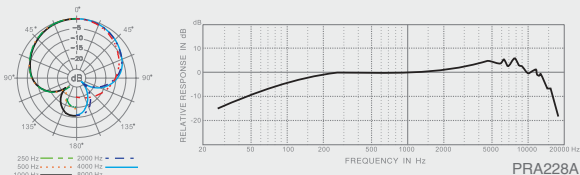

## PRA268A

### Instrument Microphone

Overhead / Eastern & Western Strings / Brass / Drums

This back electret condenser microphone is intended for drum set overhead or hi-hat. It is also suitable for mid-high frequency instruments. The PRA268A reproduces the brightened mid and delicate high range.

- Specially designed for mid-high instrument reinforcement and recording
- Sturdy metal body
- Durable, reliable professional performance
- High energy neodymium magnet increase the output level
- DRKA3C2 includes 2 PRA268As

### Specifications

Type	Back electret, Ø9.7 mm (Ø0.38")
Polar Pattern	Supercardioid
Frequency Response	50-16,000 Hz
Sensitivity	-43 dBV/Pa (7.1 mV)
Output Impedance	200 Ω
Min. Load Impedance	1,000 Ω
S/N Ratio	69 dB
Equivalent Output Noise	25 dB
Max. SPL	137 dB SPL
Dynamic Range	112 dB
Power Requirements	12-52V DC, 2 mA
Finish	Black
Connector	XLR3M
Dimensions	Ø29 × 165 mm, Ø1.14" × 6.5"
Net Weight	180 g (6.4 oz)
Accessories Furnished	S09 windscreen, HM37S clip with screw knob, YA2 threaded adapter, Pouch
Packaging	Colorful outer packaging

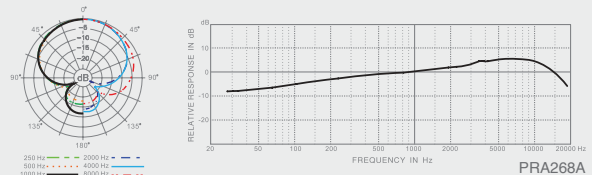

# Drum Sets



## DRK681

### 8-Piece Condenser Drum Microphone Set

Stage / Studio / Strings / Brass / Percussion

This full condenser drum set comprises 4 PRA383XLRs covering tom-tom and snare, 1 boundary E100 kick mic, and 3 E109s condenser mics for overheads and hi-hat. These high quality condenser microphones are also good for strings, winds and percussions.

DRK681 drum set includes:

- 1 E100 boundary kick mic, cardioid polar pattern
- 4 PRA383XLRs covering tom-tom and snare; cardioid polar pattern, gooseneck for best sound capturing
- 3 E109s condenser mics for overheads and hi-hat cardioid polar pattern

#### Specifications

	3 HM10S mic clips with screw knob for E109
Accessories Furnished	3 YA2 threaded adapters 3 S20 windscreen for E109s 4 PS418S preamps
Packaging	#3 aluminum box and colorful outer packaging



## DRKB5C2MKII

### 7-Piece Studio-Grade Drum Microphone Set

Stage / Studio / Percussion

The DRKB5C2MKII drum microphone set is an ideal candidate for both stage performances and the professional recording studio. It includes 7 mics to match different instruments.

The DRKB5C2MKII is comprised of 1 PRO218A for kick mic, 3 PRO228A covering tom-toms and snares, 2 PRO268B condenser mics for overheads, and 1 PRA288A for snare drum metal noise.

These high quality condenser microphones are also good for strings, winds and percussions, providing wide frequency response, high open circuit sensitivity, fast impact response and high dynamic range.

DRKB5C2MKII drum set includes:

- 1 PRO218A for kick mic, supercardioid, 174 dB extra high SPL
- 3 PRO228As covering tom-tom and snare, super cardioid
- 2 PRO268Bs condenser mics for overheads, super cardioid
- 1 PRA288A for snare drum metal noise, cardioid

#### Specifications

	1 HM27S mic clips with screw knob for PRO218A 2 HM30S mic clips with screw knob for PRO268Bs 1 HM10S mic clips with screw knob for PRA288A
Accessories Furnished	2 S20 windscreens for PRO268Bs 7 YA2 threaded adapters 3 Fixed clips with screw knob
Optional Accessories	HM12A universal clamp
Packaging	A4 box and colorful outer packaging





## DRKF5H3

### Super 8 Drum Microphone Set

Stage / Studio / Percussion

The frequency response of each microphone from the DRKF5H3 is tailored according to the instrument spectrum, the SPL and close miking characteristics of drums. The unique design captures the flavor and the impact response of each individual drum in a set.

The DRKF5H3 is comprised of 2 HO8s covering cymbals, 1 FK2 for kick drum, 3 FT4s for tom-tom, 1 FS6 for snare, and 1 HI10 for hi-hat. This mic set is suitable for Jazz music and also excellent for other instruments.

DRKF5H3 drum set includes:

- 1 FK2 supercardioid, for kick
- 3 FT4s supercardioid, for tom-tom
- 1 FS6 supercardioid, for snare
- 2 HO8s large diaphragm condenser, super cardioid, for cymbals
- 1 HI10 condenser, cardioid, for hi-hat

#### Specifications



Accessories Furnished	1 HM10S mic clip with screw knob for HI10 8 YA2 threaded adapters 2 H6A brackets for HO8 2 Screw rings for HO8 5 Fixed clips with screw knob (FK2 / FT4 / FS6)
Optional Accessories	HM12A universal clamp HM12D universal clamp with gooseneck
Packaging	A6 protective carrying case and colorful outer packaging



## DRKK5C2

### 7 Drum Mic Set with Cables and Clamps

Stage / Studio / Percussions

7 mic set, comprised of 3 tom-tom mics, 1 snare mic (with permanent clips), 1 PRA218B for kick, and 2 E102s condenser for overheads. Packed in an aluminum case with clips, drum clamps, threaded adapters and 7 microphone cables.

DRKK5C2 drum set includes:

- 1 PRA218B supercardioid, for kick
- 3 D10Cs supercardioid, for tom-tom
- 1 D10D supercardioid, for snare
- 2 E102s condenser, cardioid, for cymbals

#### Specifications



Accessories Furnished	1 HM27S mic clip with screw knob for PRA218B 4 HM28 mic clips for tom-tom and snare 5 Screw rings for PRA218B, D01C and D10D 2 HM10S mics clips with screw knob for E102s 7 YA2 threaded adapters 4 HM12A universal clamps 7 XLR3F-XLR3M 7-meter microphone cables (1 of 7 cables has a 90 degree connector)
Packaging	#3 protective aluminum box and colorful outer packaging



## DRKA3

### Simple 3 Drum Microphone Set

Live Stage / Practice Room

Designed for live stage and practice room. Simple, yet complete with 1 PRA218A for kick, 2 x PRA228A for tom-tom and others, All microphones included permanent attached mic clip.

DRKA3 drum set includes:

- 1 PRA218A for kick
- 2 PRA228A for tom-tom and others

#### Specifications



Accessories Furnished	3 YA2 threaded adapters
Optional Accessories	HM12A universal clamp
Packaging	#3 aluminum box and colorful outer packaging



## DRKA3C2

### Compact 5 Microphone Set

Live Stage / Practice Room

The DRKA3C2 drum set microphone is designed for live stage and practice room. Simple and complete, it is comprised of 2 PRA268AH condenser for overheads, 1 PRA218A for kick, and 2 PRA228A for tom-tom. All microphones include permanent attached mic clip.

The DRKA3C2 drum set includes:

- 1 PRA218A supercardioid for kick
- 2 PRA228As supercardioid for tom-tom and snare
- 2 PRA268AHs condenser, supercardioid for cymbals and hi-hat

#### Specifications



Accessories Furnished	5 permanent attached mic clips 5 YA2 threaded adapters
Optional Accessories	HM12A universal clamp
Packaging	A3 protective box and colorful outer box



## DRKA5

### Easy 5 Drum Microphone Set

Live Stage / Practice Room

Designed for live stage and practice room. Easy yet complete with 1 PRA218A for kick, 4 x PRA228A for tom-tom and others, All microphones included permanent attached mic clip.

The DRKA5 drum set includes:

- 1 PRA218A for kick
- 4 PRA228A for tom-tom and others

#### Specifications



Accessories Furnished	5 YA2 threaded adapters
Optional Accessories	HM12A universal clamp
Packaging	A3 protective box and colorful outer box



## DRKA5C2

### Extended 7 Microphone Set

Live Stage / Project Studio / Practice Room / Percussion

The DRKA5C2 drum set microphone is designed for live stage and practice room. It is comprised of 2 PRA268AH condenser for overheads, 1 PRA218A for kick, and 4 PRA228A for tom-tom and snare. All microphones include permanent attached mic clip.

The DRKA5C2 drum set includes:

- 1 PRA218A supercardioid, for kick
- 4 PRA228As supercardioid, for tom-tom and snare
- 2 PRA268AHs condenser, supercardioid, for cymbals and hi-hat

#### Specifications



Accessories Furnished	2 HM10S mic clips with screw knob for PRA268A 5 permanent attached mic clips 7 YA2 threaded adapters
Optional Accessories	HM12A universal clamp
Packaging	A3 protective box and colorful outer box



**Value Packs**



For the professional artists who are always performing at different occasions, Superlux offers a convenient microphone value pack. All the necessary elements are stored in one handy carrying bag, so it is very easy to travel with this value pack. Choose the value pack for yourself.

The value packs includes: microphone, mic cable, mic clip, threaded adapter, microphone boom stand, nylon pouch, and a handy carry bag.



## MSKA Singer Pack

**Singer / Teacher / Presenter**

High C/P value vocal microphone ECOA, best selling microphone boom stand MS108E, nylon pouch, HM9A mic clip, 6-meter mic cable, top-open carrying bag that holds everything.

The MSKA Singer Pack includes:

- 1 ECOA1 vocal microphone
- 1 6-meter mic cable, XLR3F-XLR3M connector or XLR3F-1/4" TS connector
- 1 Mic nylon pouch
- 1 HM9A mic clip
- 1 MS108E boom stand (5/8" to 3/8" threaded adapter included)
- 1 Top-open carrying bag

MSKAX

Microphone cable with XLR3F-XLR3M connector

MSKAP

Microphone cable with XLR3F-1/4" TS connector



6-meter microphone cable



Nylon pouch



Carrying canvas bag





## MSK10B

### Instrument Microphone Pack

Guitar Player / String Player / Brass Player / Percussion / Vocal

The MSK10B instrument microphone value pack contains instrument microphone D10B incorporating humbucking coil bundle with MS108E boom stand, additional microphone cable, mic clip, and carrying bag.

The MSK10B instrument microphone value pack includes:

- 1 D10B instrument microphone
- 1 6-meter mic cable, XLR3F-XLR3M connector or XLR3F-1/4" TS connector
- 1 Nylon mic pouch
- 1 HM9A mic clip
- 1 MS108E boom stand (5/8" to 3/8" threaded adapter included)
- 1 Top-open carrying bag

MSK10BX Microphone cable with XLR3F-XLR3M connector  
 MSK10BP Microphone cable with XLR3F-1/4" TS connector



## MSK124

### Condenser Microphone Pack

Guitar Player / String Player / Brass Player

The MSK124 condenser mic pack is specially designed for professional instrument/vocal amplification application. It includes: E124D instrument/vocal microphone packed with light weight aluminium traveller stand MS128. The E124D condenser microphone can be powered by phantom or one 1.5V battery, making this package the best for acoustic instrument touring musicians.

The MSK124 condenser microphone pack includes:

- 1 E124D instrument/vocal condenser microphone (phantom power or one 1.5V battery)
- 1 6-meter mic cable, XLR3F-XLR3M connector or XLR3F-1/4" TS connector
- 1 S09 wind screen
- 1 HM16S mic clip with screw knob
- 1 YA2 threaded adapter
- 1 MS128 light weight aluminum boom stand (5/8" to 3/8" threaded adapter included)
- 1 Top-open carrying bag, 1 Nylon mic pouch

MSK124X Microphone cable with XLR3F-XLR3M connector  
 MSK124P Microphone cable with XLR3F-1/4" TS connector





*Superlux*

# Installation

# Gooseneck Microphone

## E326PRO

### High Quality Gooseneck Microphone

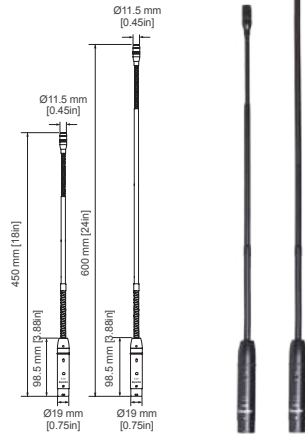

#### Conference / Lectern / House of Worship / Temple

The E326PRO is a high quality compact gooseneck back electret condenser conference microphone. Its durable double bend gooseneck has passed a bending test, which means it didn't break after over 3000 times of bending. It has a inter-changeable capsule. A cardioid is included in the package, and the supercardioid and omni are optional, with 45 cm and 60 cm version available.

- Rugged construction
- High precision engineered miniature condenser capsule
- 3 types of capsule: cardioid, supercardioid and omni
- Highly reliable contact for capsule modules
- Professional sound quality
- RF immunity
- Double bend gooseneck

E326U/M PRO	cardioid, 45 cm (18") long
E326H/M PRO	supercardioid, 45 cm (18") long
E326O/M PRO	omni, 45 cm (18") long
E326U/L PRO	cardioid, 60 cm (24") long
E326H/L PRO	supercardioid, 60 cm (24") long
E326O/L PRO	omni, 60 cm (24") long

#### Specifications

Type	Back electret, Ø11.5 mm (Ø0.45")
Polar Pattern	Cardioid / Supercardioid / Omni
Frequency Response	20-20,000 Hz
Low Frequency Filter	150 Hz, -6 dB/oct
Sensitivity	-42 dBV/Pa (7.9 mV)
Output Impedance	200 Ω
Min. Load Impedance	1,000 Ω
S/N Ratio	72 dB
Equivalent Output Noise	22 dB
Max. SPL	138 dB SPL
Dynamic Range	116 dB
Power Requirements	9-52V DC, 1.9 mA
Finish	Black
Connector	XLR3M
Dimensions	Capsule: Ø11.5 mm (Ø0.45"), Length: 450 / 600 mm (18" / 24")
Net Weight	151 g (5.3 oz) / 167 g (5.9 oz)
Accessories Furnished	S55F windscreen
Packaging	Colorful outer packaging

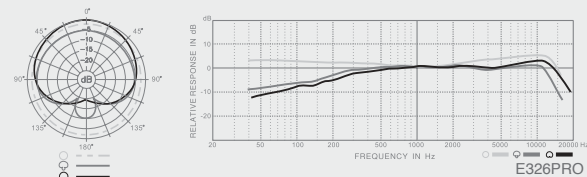

## E321

### Gooseneck Microphone

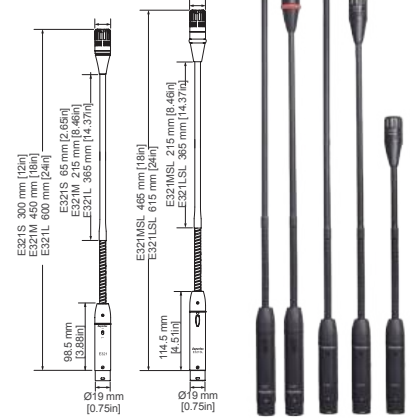

#### Conference / Lectern / House of Worship / Temple

The E321 gooseneck microphone is black, with inter-changeable capsules, standard pack with supercardioid capsule. Cardioid and omni capsules are available as options. It features a built-in 150 Hz HPF.

- High quality gooseneck vocal microphone
- Inter-changeable capsules with supercardioid, cardioid, and omni capsule available
- One bend near the base
- Three length options (S/M/L), an ON/OFF switch and an LED light are available

U: Cardioid capsule  
H: Supercardioid capsule  
O: Omni capsule

E321S	30 cm (12"), external HPF 150 Hz, -6 dB/oct
E321S/SL	30 cm (12"), with on/off switch, and LED ring
E321M	45 cm (18"), external HPF 150 Hz, -6 dB/oct
E321M/SL	45 cm (18"), with ON/OFF switch, and LED ring
E321L	60 cm (24"), external HPF 150 Hz, -6 dB/oct
E321L/SL	60 cm (24"), with ON/OFF switch, and LED ring

#### Specifications

Type	Back electret, Ø16 mm (Ø0.63")
Polar Pattern	Cardioid / Supercardioid / Omni
Frequency Response	20-18,000 Hz
Low Frequency Filter	150 Hz, -6 dB/oct
Sensitivity	Cardioid / Supercardioid: -40 dBV/Pa (10 mV) Omni: -42 dBV/Pa (7.9 mV)
Output Impedance	600 Ω
Min. Load Impedance	2,000 Ω
S/N Ratio	Cardioid / Supercardioid: 72 dB; omni: 70 dB
Equivalent Output Noise	Cardioid / Supercardioid: 22 dB; omni: 24 dB
Max. SPL	Cardioid / Supercardioid: 135 dB SPL; omni: 137 dB SPL
Dynamic Range	Cardioid / Supercardioid: 113 dB; omni: 113 dB
Power Requirements	Phantom 9-52V DC, 4mA
Finish	Titanium grey
Connector	XLR3M
Dimensions	Capsule: Ø20 mm (Ø0.79"); Length: 300 / 450 / 600 mm (12" / 18" / 24")
Net Weight	200 g (7 oz)
Accessories Furnished	S20 windscreen
Packaging	Colorful outer packaging

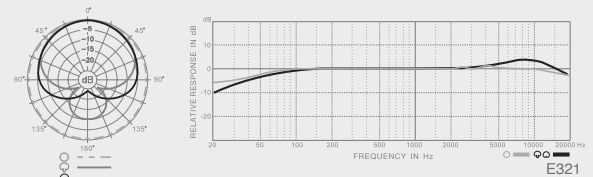

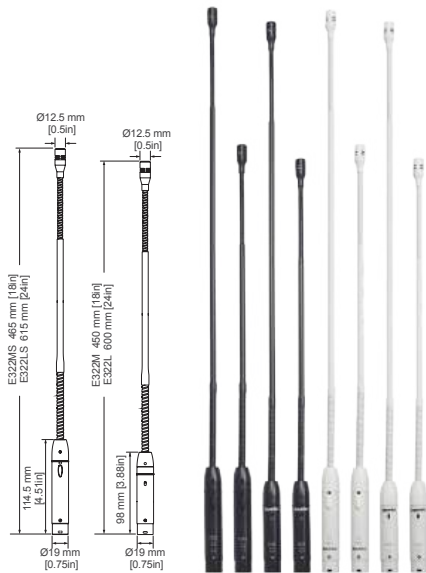

## E322 Gooseneck Microphone

Conference / Lectern / House of Worship / Temple

The E322 is a miniature condenser capsule, gooseneck microphone for conference applications. It has a double bend for easy position setting. It comes in 2 lengths and in black or white. It possesses an external accessible low cut filter to filter out un-wanted noise.

- High quality Gooseneck vocal microphone
- 2 length (M/L) versions, ON/OFF switch, available in black or white
- Double bend

B: Black  
W: White

E322MB	45 cm, black (external low cut filter)
E322MB/S	46.5 cm, black, ON/OFF switch
E322MW	45 cm, white (external low cut filter)
E322MW/S	46.5 cm, white, ON/OFF switch
E322LB	60 cm, black (external low cut filter)
E322LB/S	61.5 cm, black, ON/OFF switch
E322LW	60 cm, white (external low cut filter)
E322LW/S	61.5 cm, white, ON/OFF switch

### Specifications

Type	Back electret, Ø9.7 mm (Ø0.38")
Polar Pattern	Cardioid
Frequency Response	40-20,000 Hz
Sensitivity	-40 dB V/Pa (10 mV)
Output Impedance	600 Ω
Min. Load Impedance	2,000 Ω
S/N Ratio	70 dB
Equivalent Output Noise	24 dB
Max. SPL	127 dB SPL
Dynamic Range	103 dB
Power Requirements	9-52V DC, 4mA
Finish	Black, White
Connector	XLR3M
Dimensions	Capsule: Ø12.5 mm (Ø0.49") Length: without on/off switch 450 / 600 mm (18" / 24"), with ON/OFF switch 465 / 615 mm (18.3" / 24.2")
Net Weight	160 / 220 g (5.6 / 7.8 oz)
Accessories Furnished	S21F windscreens, HM22 mounting flange, HM23 shock mount flange
Packaging	Colorful outer packaging

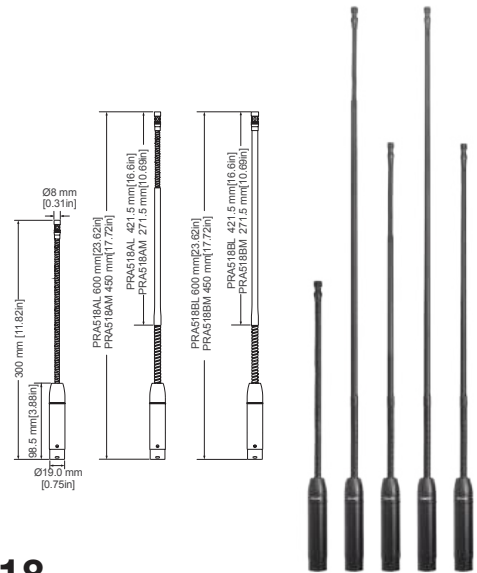
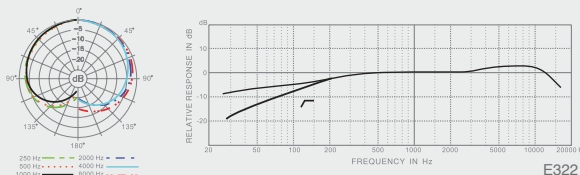

## PRA518 Gooseneck Microphone

Conference / Lectern / House of Worship / Temple

Mini back electret gooseneck condenser conference microphone PRA518 provides the frequency response and cardioid directivity for conference application. There are 5 versions to choose from: full bend, double bend or single bend, 30, 45 or 60 cm in length. The small capsule produces sleek appearance.

- Ø8 mm mini capsule
- Back electret cardioid capsule
- Tailored conference speech frequency response
- Single bend, double bend, and full bend gooseneck are available

PRA518AS	Ø8 × 30 cm (12") full bend
PRA518AM	Ø8 × 45 cm (18") double bend
PRA518AL	Ø8 × 60 cm (24") double bend
PRA518BM	Ø8 × 45 cm (18") single bend
PRA518BL	Ø8 × 60 cm (24") single bend

### Specifications

Type	Back electret, Ø6 mm (Ø0.24")
Polar Pattern	Cardioid
Frequency Response	50-16,000 Hz
Sensitivity	-39 dB V/Pa (11.2 mV)
Output Impedance	200 Ω
Min. Load Impedance	1,000 Ω
S/N Ratio	68 dB
Equivalent Output Noise	26 dB
Max. SPL	130 dB SPL
Dynamic Range	104 dB
Power Requirements	9-52V DC, 3 mA
Finish	Black
Connector	XLR3M
Dimensions	Capsule: Ø8 mm (Ø0.31") Length: 300 / 450 / 600 mm (12" / 18" / 24")
Net Weight	130-165 g (4.6-5.8 oz)
Accessories Furnished	HM22 mounting flange, S04 windscreens
Packaging	Colorful outer packaging

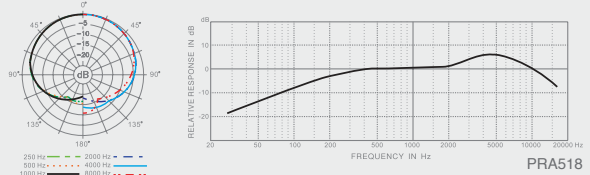

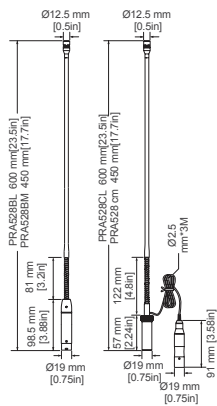

## PRA528

### Gooseneck Microphone

Conference / Lectern / Houses of Worship / Temple

The PRA528B/C series are specially designed back electret condenser microphones for conferences. They have the features needed for conferences such as tailored frequency response, excellent cardioid polar pattern, and high gain before feedback. Each member in the PRA528B/C series has an adjustable gooseneck, which makes it convenient to change the direction when installed in fixed places. It has 2 length versions 45 cm, 60 cm, and 2 connection methods: B direct plug in model and C separate pre-amplifier model.

- Direct plug-in at fixed places version and separated mic pre version are available
- Back electret cardioid capsule
- Tailored conference reinforced vocal frequency response
- Single bend gooseneck structure

PRA528BM	45 cm, direct plug in
PRA528BL	60 cm, direct plug in
PRA528CM	45 cm, separate pre-amplifier, 2.5-meter long cable
PRA528CL	60 cm, separate pre-amplifier, 2.5-meter long cable

### Specifications

Type	Back electret, Ø9.7 mm (Ø0.38")
Polar Pattern	Cardioid
Frequency Response	50-16,000 Hz
Sensitivity	-39 dBV/Pa (11.2 mV)
Output Impedance	200 Ω
S/N Ratio	68 dB
Min. Load Impedance	1,000 Ω
Equivalent Output Noise	26 dB
Max. SPL	132 dB SPL
Dynamic Range	106 dB
Power Requirements	Phantom 9-52V DC, 3 mA
Finish	Black
Connector	XLR3M
Dimensions	Capsule: Ø12.5 mm (Ø0.49") Length: 450 / 600 mm (18"/24")
Net Weight	150~220 g (5.3~7.8 oz)
Accessories Furnished	PRA528B serial: S21F windscreen, HM22 mounting flange, HM23 shock mount flange PRA528C serial: HM22 mounting flange, S05 windscreen
Packaging	Colorful outer packaging

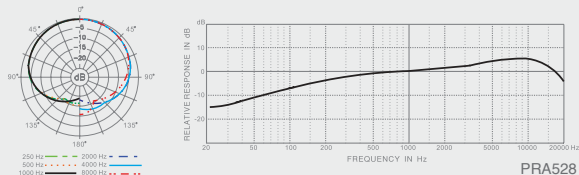

## PRA618

### Gooseneck Dynamic Microphone

Conference / Lectern / DJ

The PRA618 is a dynamic gooseneck microphone for systems without phantom power supply. It's easy to use, just plug and play. No phantom power is needed.

- Small dynamic supercardioid capsule
- Tailored vocal frequency response
- High gain before feedback
- Double bend gooseneck structure

PRA618M	45 cm, double bend
PRA618L	60 cm, double bend

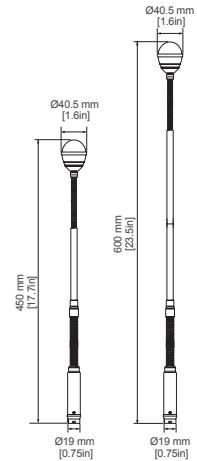

### Specifications

Type	Dynamic
Polar Pattern	Supercardioid
Frequency Response	100-10,000 Hz
Sensitivity	-56 dBV/Pa (1.6 mV)
Output Impedance	500 Ω
Min. Load Impedance	2,000 Ω
Max. SPL	140 dB SPL
Finish	Black
Connector	XLR3M
Dimensions	Capsule: Ø40.5 mm (Ø1.59") Length: 450 / 600 mm (18" / 24")
Net Weight	PRA618M: 250 g (8.8 oz) PRA618L: 320 g (11.2oz)
Accessories Furnished	HM22 mounting flange
Optional Accessories	DS003 mic base
Packaging	Colorful outer packaging

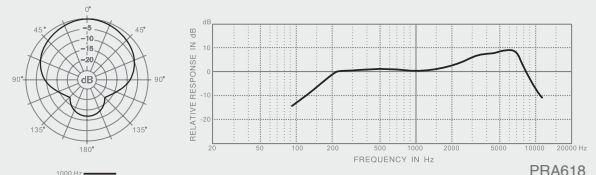

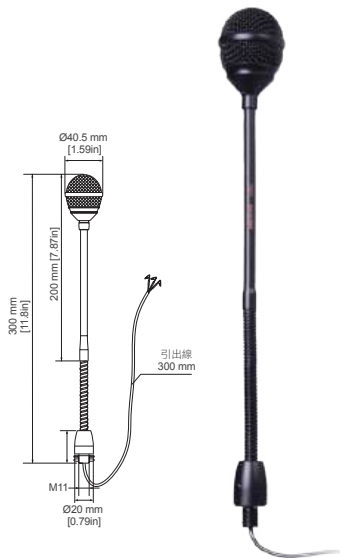

## D302

### Installation Gooseneck Microphone

#### Conference / Lectern

The D302 conference style dynamic microphone is designed for the speech and conference installation market. It incorporates high sensitivity and wide frequency response to precision sound pick up. Simple mounting with tightening gaskets to install the microphone onto a podium or to fix with 5/8" nut on a base. It shares the same capsule as the PRA618.

- 5/8" thread for easy mounting
- Supercardioid polar pattern emphasizes on-axis sound while suppressing surrounding noise
- Tailored conference speech frequency response
- Noiseless single bending

D302 Gooseneck 30 cm, pigtail: 30 cm cable

#### Specifications

Type	Dynamic
Polar Pattern	Supercardioid
Frequency Response	100-10,000 Hz
Sensitivity	-56 dBV/Pa (1.6 mV)
Output Impedance	500 Ω
Min. Load Impedance	2,000 Ω
Max. SPL	140 dB SPL
Finish	Black
Connector	Pig tail
Dimensions	Capsule: Ø40.5 mm (Ø1.59") Length: 300 mm (12")
Net Weight	150 g (5.3 oz)
Packaging	White box

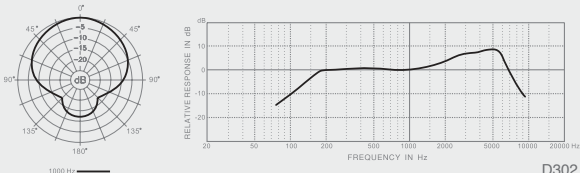

D302

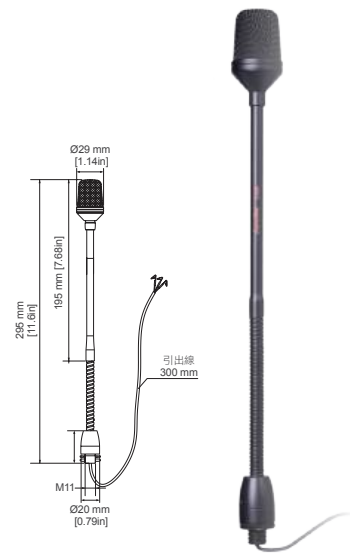

## E306

### Installation Gooseneck Condenser Mic

#### Conference / Lectern

The E306 conference style condenser microphone, which is designed for the speech, conference, and installation market. It incorporates frequency response to precision sound pick up. Simple mounting with tightening gaskets to install the microphone onto a podium or fix with 5/8" nut on a base. It shares the same capsule as the PRA528DS.

- 5/8" thread for easy mounting
- Cardioid polar pattern to emphasize on-axis sound while suppressing surrounding noise
- Tailored conference speech frequency response
- Noiseless single bending

E306 Gooseneck 29.5 cm, pigtail: 30 cm cable

#### Specifications

Type	Back electret, Ø9.7 mm (Ø0.38")
Polar Pattern	Cardioid
Frequency Response	50-16,000 Hz
Sensitivity	-40 dBV/Pa (10 mV)
Output Impedance	200 Ω
Min. Load Impedance	1,000 Ω
Max. SPL	137 dB SPL
Power Requirements	3-9V DC
Finish	Black
Connector	Pigtail
Dimensions	Capsule: Ø29 mm (Ø1.14") Length: 295 mm (11.6")
Net Weight	150 g (5.3 oz)
Accessories Furnished	S18 windscreen
Packaging	White box

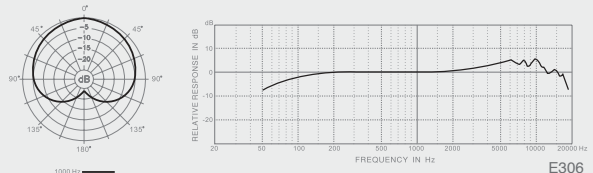

E306

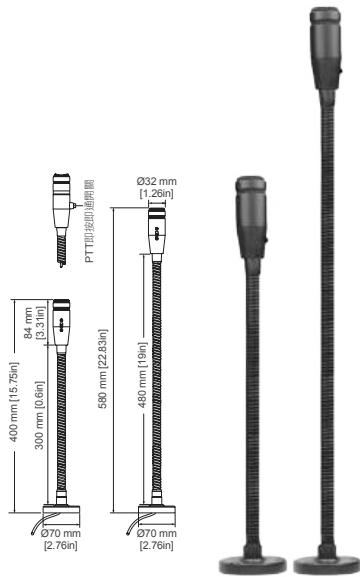

## PRA538

### Heavy Duty Gooseneck Microphone

Communication / Lectern / PA

The PRA538 is a heavy duty thick gooseneck microphone for heavier operation and long life. It features a small type dynamic supercardioid capsule, tailored to precision sound pick up, good directivity. The microphone can be installed using a metal flange with 3 screws, which are all included.

- 15 mm diameter durable thick gooseneck tube
- Mute and PTT switch option
- 40 cm and 58 cm option
- Pigtail, 1.8-meter cable
- Full bend gooseneck structure

PRA538S	40 cm
PRA538M	58 cm
PRA538SS	40 cm, installed on DS003
PRA538MS	58 cm, installed on DS003
PRA538MS	PTT Push to talk

### Specifications

Type	Dynamic
Polar Pattern	Supercardioid
Frequency Response	100-15,000 Hz
Sensitivity	-58 dBV/Pa (1.3 mV)
Output Impedance	500 Ω
Min. Load Impedance	2,000 Ω
Max. SPL	135 dB SPL
Finish	Black
Connector	Pigtail
Dimensions	Capsule: Ø32 mm (Ø1.26") Length: 400 / 580 mm (15.75" / 22.83")
Net Weight	490 g - 530 g (17.2 oz - 18.7 oz)
Accessories Furnished	S19 windscreen
Packaging	White box

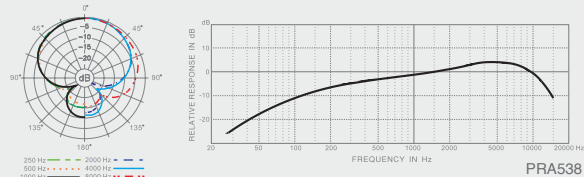

## E309DPRO

### Gooseneck Condenser Microphone

Conference / Lectern / Houses of Worship / Temple

The E309DPRO is a high quality gooseneck microphone with an interchangeable capsule. It is mounted on a metal base which includes membrane switch. It provides 4 kinds of set-up: PTT, PTM, power up on and power up off. The metal base has XLR3M output and a terminal block connection.

- Membrane switch, 4 programmable setups
- ON/OFF switch with LED indicator
- High quality condenser capsule and is available for a cardioid, supercardioid or omni pickup pattern
- RF immunity
- Double bend gooseneck structure

E309DU PRO	Cardioid capsule
E309DH PRO	Supercardioid capsule
E309DO PRO	Omni capsule

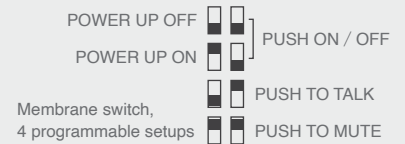

### Specifications

Type	Back electret, Ø11.5 mm (Ø0.45")
Polar Pattern	Cardioid / Supercardioid / Omni
Frequency Response	20-20,000 Hz
Sensitivity	-42 dBV/Pa (12.6 mV)
Output Impedance	200 Ω
Min. Load Impedance	1,000 Ω
S/N Ratio	75 dB
Equivalent Output Noise	19 dB
Max. SPL	124 dB SPL
Dynamic Range	105 dB
Power Requirements	48V DC, 5.5 mA
Finish	Black
Connectors	XLR3M & terminal block
Dimensions	Capsule: Ø11.5 mm (Ø0.45"); Height: 445 mm (17.52")
Net Weight	938 g (33.1 oz)
Accessories Furnished	S55F windscreen
Optional Accessories	10-meter mic cable (pigtail-XLR3M) SFM10FM: 10-meter XLR3M-XLR3F
Packaging	Colorful outer packaging

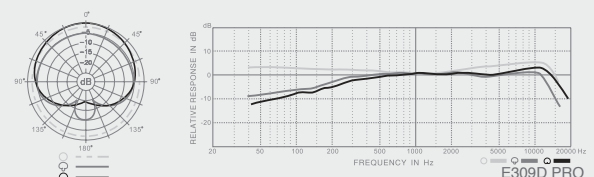



## E361

### Continuous Variable Pattern Gooseneck Mic

Conference / Lectern / House of Worship / Temple

The E361 is a condenser gooseneck microphone with a continuously-variable pickup pattern achieved by its dual capsule design. The variable pattern control is selected by the knob on its base, making the E361 flexible for a variety of applications. It mounts on a metal base with a membrane switch that provides 4 kinds of set-up: PTT, PTM, power up on, and power up off. The metal base has XLR3M output and terminal block connection.

- Membrane switch, 4 programmable setups
- On/off switch with LED indicator
- -31 dBV highly sensitive condenser capsule
- RF immunity
- Double bend gooseneck structure

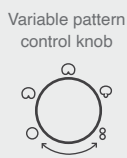
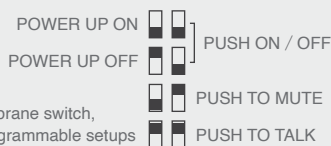

### Specifications

Type	Back electret, Ø9.7 mm (Ø0.38")
Polar Pattern	Continuous variable pattern
Frequency Response	80-18,000 Hz
Sensitivity	-31 ± 2 dBV/Pa (28.2 mV)
Output Impedance	200 Ω
Min. Load Impedance	1,000 Ω
S/N Ratio	79 dB
Equivalent Output Noise	15 dB
Max. SPL	120 dB SPL
Dynamic Range	105 dB
Power Requirements	48V DC, 8.6 mA
Finish	Black
Connector	XLR3M
Dimensions	Capsule: Ø16 mm (Ø0.63"), Height: 465 mm (18.31")
Net Weight	943 g (33.2 oz)
Accessories Furnished	S56 windscreen
Optional Accessories	10-meter microphone cable (pigtail-XLR3M), SFM10FM: 10-meter XLR3M-XLR3F microphone cable
Packaging	Colorful outer packaging

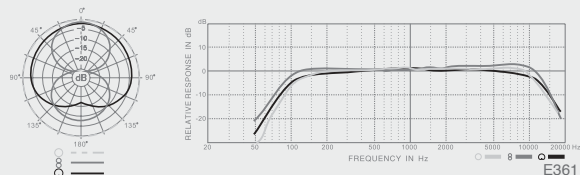

## PRA528DS

### Gooseneck Microphone

Conference / Lectern / PA

The PRA528DS is a gooseneck microphone with a base. Specially tailored with conference speech frequency response, it gets higher gain before feedback, as well as farther sound pick up distance. It can be powered by phantom or battery. Larger pop screen to prevent wind noise and flush mount XLR-3M socket for easy set-up.

- Dual powered by phantom or battery
- Back electret condenser
- Tailored conference speech frequency response
- Double bend gooseneck

### Specifications

Type	Back electret, Ø9.7 mm (Ø0.38")
Polar Pattern	Cardioid
Frequency Response	50-16,000 Hz
Sensitivity	-35 dBV/Pa (17.8 mV)
Output Impedance	Phantom: 200 Ω, Battery: 600 Ω
Min. Load Impedance	Phantom: 1,000 Ω, Battery: 2,000 Ω
S/N Ratio	70 dB
Equivalent Output Noise	24 dB
Max. SPL	Phantom: 124 dB SPL, Battery: 114 dB SPL
Dynamic Range	Phantom: 100 dB, Battery: 90 dB
Power Requirements	Phantom: 12-52V DC, 3 mA Battery: 1.5V AA/UM3, 1.2 mA
Finish	Black
Connector	XLR3M
Dimensions	Capsule: Ø29 mm (Ø1.14") Height: 460 mm (18.11") without the base
Net Weight	1,000 g (35.3 oz)
Accessories Furnished	S18 windscreen, 1.5 V AA alkaline battery
Optional Accessories	SFM10FM: 10-meter XLR3F-XLR3M microphone cable
Packaging	A3 protective carry case, colorful outer packaging

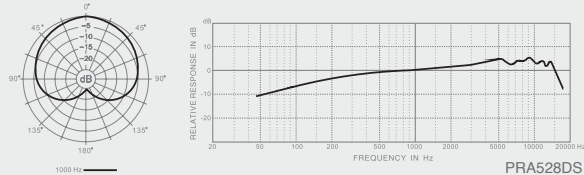

# Gooseneck Microphone Optional Accessories



## HM22

### Mounting Flange

Installation aperture: Ø42 mm (1.65")



## HM23

### Shock Mount Flange

Installation aperture: Ø50.8 mm (2")



## HM24

### XLR3F Flush Socket

XLR3F flush socket with open end cable  
Cable Length: 25 cm (10")  
Installation aperture: Ø43 mm (Ø1.69")



## HM24C

### XLR3F Flush Socket

XLR3F flush socket with XLR3M connector  
Cable Length: 2-meter (6')  
Installation aperture: Ø43 mm (Ø1.69")



## GT2B

### 5/8" Thread Flange

5/8" Screw Flange



## GT6F

### XLR-3F Flange

XLR3F base, surface mount with open end cable



DS003S



DS003AS



## PS518

### Gooseneck Mic Base

10-meter mic cable (open end-XLR3M), can be connected from the rear or the bottom  
Powered by 48V DC Phantom  
Programmable soft-touch membrane switch:  
Push to talk / push to mute  
power up ON / power up OFF



## DS002

### Gooseneck Mic Base

XLR3F to XLR3M socket for convenient connection

## DS003

### Gooseneck Mic Base

XLR3F to XLR3M socket for convenient connection  
DS003 flush XLR3F Socket  
DS003S same as DS003 with ON/OFF switch  
DS003A Raised XLR3F socket with lock  
DS003AS same as DS003A with ON/OFF switch



## E303

### Acoustic Boundary Cardioid Microphone

Lectern / Conference / Tap Dance / Piano

The E303 directional boundary microphone is designed for flat surface placement. The miniature condenser capsule provides wide frequency response and reduces reflections to minimize phasing distortion. Its clean and high sensitivity signal results in clear sound without coloration. It features a built-in pre-amplifier that doesn't need an external power adapter.

- Sturdy die-cast case
- Double layers metal grille
- High gain before feedback

E303B black  
E303W white

#### Specifications

Type	Back electret, Ø9.7 mm (Ø0.38")
Polar Pattern	Cardioid
Frequency Response	30-18,000 Hz
Sensitivity	-39 dBV/Pa (11.2 mV)
Output Impedance	600 Ω
Min. Load Impedance	2,000 Ω
S/N Ratio	70 dB
Equivalent Output Noise	24 dB
Max. SPL	127 dB SPL
Dynamic Range	103 dB
Power Requirements	Phantom 9-52V DC, 4 mA
Finish	Black, white
Connector	TA3M
Dimensions	Ø85 × 20.5 mm (Ø3.35" × 0.81")
Net Weight	180 g (6.3 oz)
Accessories Furnished	33' (10-meter) TA3F-XLR3M microphone cable
Packaging	Colorful outer packaging

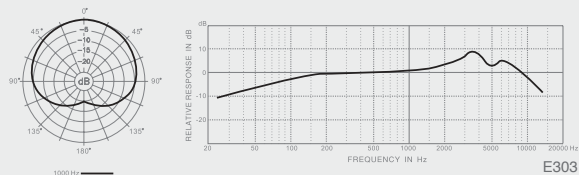

## E304

### Acoustic Boundary Omni Microphone

Lectern / Conference / Tap Dance / Piano

The E304 omni boundary microphone is designed for flat surface placement. The miniature condenser capsule provides wide frequency response and reduces reflections to minimize phasing distortion. Its clean and high sensitivity signal results in clear sound without coloration. It features a built-in pre-amplifier that doesn't need an external power adapter.

- Sturdy die-cast case
- Double layers metal grille
- High gain before feedback

E304B black  
E304W white

#### Specifications

Type	Back electret, Ø9.7 mm (Ø0.38")
Polar Pattern	Omni
Frequency Response	20-18,000 Hz
Sensitivity	-39 dBV/Pa (11.2 mV)
Output Impedance	600 Ω
Min. Load Impedance	2,000 Ω
S/N Ratio	70 dB
Equivalent Output Noise	24 dB
Max. SPL	127 dB SPL
Dynamic Range	103 dB
Power Requirements	Phantom 9-52V DC, 4 mA
Finish	Black, white
Connector	TA3M
Dimensions	Ø85 × 22.5 mm (Ø3.35" × 0.88")
Net Weight	200 g (7 oz)
Accessories Furnished	33' (10-meter) TA3F-XLR3M microphone cable
Packaging	Colorful outer packaging

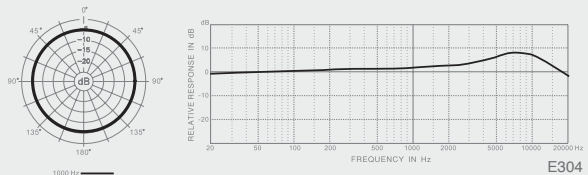



## PRA418

### Omni Acoustic Boundary Microphone

Lectern / Conference / Tap Dance / Piano / Drama

The PRA418 omni boundary microphone is designed for flat surface placement. The miniature condenser capsule provides wide frequency response and reduces reflections to minimize phasing distortion. Clean and high sensitivity signal results in clear sound without coloration. The mic preamplifier is included in the PS418D. It can be powered by phantom or 1.5V battery.

- PS418D preamp, built-in 80 Hz HPF to reduce ambient noise
- Sturdy die-cast case
- Double layer metal grille
- AA battery working 1200 hours continuously

#### Specifications



Type	Back electret, Ø9.7 mm (Ø0.38")
Polar Pattern	Omni
Frequency Response	30-20,000 Hz
Low Frequency Filter	80 Hz
Sensitivity	Phantom: -42 dBV/Pa (7.9 mV) Battery: -44 dBV/Pa (6.3 mV)
Output Impedance	Phantom: 200 Ω; Battery: 600 Ω
Min. Load Impedance	Phantom: 1,000 Ω; Battery: 2,000 Ω
S/N Ratio	68 dB
Equivalent Output Noise	26 dB
Max. SPL	Phantom: 132 dB SPL; Battery: 118 dB SPL
Dynamic Range	Phantom: 106 dB; Battery: 92 dB
Power Requirements	Phantom 9-52V DC, 2 mA or 1.5V AA battery
Finish	Black
Connector	TA3M
Dimensions	Ø65 × 15 mm (Ø2.56" × 0.59")
Net Weight	80 g (2.8 oz)
Accessories Furnished	PS418D preamplifier, 25' (7.5-meter) TA3F-TA3F microphone cable, 1.5V AA alkaline battery
Packaging	A1 protective carrying case, Colorful outer sleeve

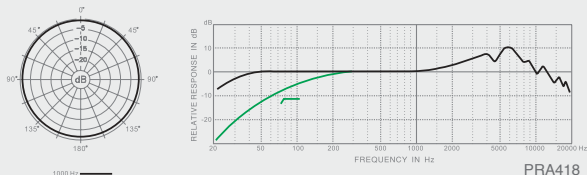

## PRA428

### Cardioid Acoustic Boundary Microphone

Lectern / Conference / Tap Dance / Piano / Drama

The PRA428 cardioid boundary microphone is designed for flat surface placement and is suitable for a professional stage or noisy working environment. Its built-in HPF filters out the sound of footsteps on the stage. The miniature condenser capsule provides wide frequency response and a natural tone, meet needs of professionals. The mic preamplifier is included in the PS418D. It can be powered by phantom or 1.5V battery.

- PS418D preamp, built-in 80 Hz HPF to reduce ambient noise
- Sturdy die-cast case
- Double layer metal grille
- AA battery working 1200 hours continuously

#### Specifications



Type	Back electret, Ø9.7 mm (Ø0.38")
Polar Pattern	Cardioid
Frequency Response	50-20,000 Hz
Low Frequency Filter	80 Hz
Sensitivity	Phantom: -44 dBV/Pa (6.3 mV) Battery: -45 dBV/Pa (5.6 mV)
Output Impedance	Phantom: 200 Ω; Battery: 600 Ω
Min. Load Impedance	Phantom: 1,000 Ω; Battery: 2,000 Ω
S/N Ratio	66 dB
Equivalent Output Noise	28 dB
Max. SPL	Phantom: 134 dB SPL; Battery: 120 dB SPL
Dynamic Range	Phantom: 106 dB; Battery: 92 dB
Power Requirements	Phantom 9-52V DC, 2 mA or 1.5V AA battery
Finish	Black
Connector	TA3M
Dimensions	64 × 92 × 16 mm (2.44" × 3.62" × 0.63")
Net Weight	110 g (3.9 oz)
Accessories Furnished	PS418D preamplifier, 25' (7.5-meter) TA3F-TA3F microphone cable, 1.5V AA alkaline battery
Packaging	A1 protective carrying case, Colorful outer sleeve

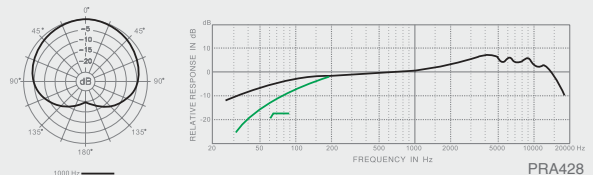



## E323

### Flush Mount Cardioid Boundary Microphone

#### Speech / General Purpose

The E323 flush mount boundary microphone has a cardioid polar pattern that can reduce the possibility of feedback when installed in a speaker amplification application. The E323 is finished in no-gloss black or white, with a built-in power circuit, and XLR3M connector.

- Full metal structure, double layer grille
- 2 anti-vibrating rubber and mounting screws
- XLR3M output connector

E323B black  
E323W white

#### Specifications

Type	Back electret, Ø9.7 mm (Ø0.38")
Polar Pattern	Cardioid
Frequency Response	60-14,000 Hz
Sensitivity	-35 dBV/Pa (17.8 mV)
Output Impedance	200 Ω
Min. Load Impedance	1,000 Ω
S/N Ratio	68 dB
Equivalent Output Noise	26 dB
Max. SPL	132 dB SPL
Dynamic Range	106 dB
Power Requirements	Phantom 12-48V DC, 2 mA
Finish	Black or white
Connector	XLR3M
Dimensions	Ø28 (34) × 73 mm [Ø1.1" (1.34") × 2.87"]
Net Weight	53 g (1.87 oz)
Accessories Furnished	Washer, shock mount sleeve, fix nut
Packaging	White box

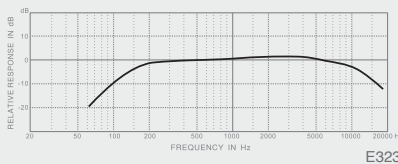
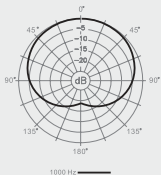

E323



## E324

### Flush Mount Omni Boundary Microphone

#### Speech / Surveillance / General Purpose

The E324 flush mount omni polar pattern boundary microphone has a wide range of pick up sound response. Finished in no-gloss black or white, with built-in power circuit, and XLR3M connector.

- Full metal structure, double layer grille
- 2 anti-vibrating rubber and mounting screws
- XLR3M output connector

E324B black  
E324W white

#### Specifications

Type	Back electret, Ø9.7 mm (Ø0.38")
Polar Pattern	Omni
Frequency Response	20-20,000 Hz
Sensitivity	-32 dBV/Pa (25 mV)
Output Impedance	200 Ω
Min. Load Impedance	1,000 Ω
S/N Ratio	68 dB
Equivalent Output Noise	26 dB
Max. SPL	132 dB SPL
Dynamic Range	106 dB
Power Requirements	Phantom 12-48V DC, 2 mA
Finish	Black or white
Connector	XLR3M
Dimensions	Ø28 (34) × 73 mm [Ø1.1" (1.34") × 2.87"]
Net Weight	53 g (1.87 oz)
Accessories Furnished	Washer, shock mount sleeve, fix nut
Packaging	White box

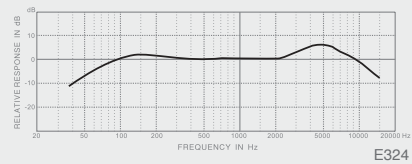
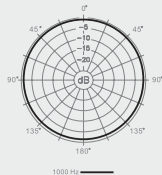

E324



## E308

### Ceiling Mic with Inter-Changeable Capsules

Conference / House of Worship / Surveillance / Stage

The E308 is a low profile miniature condenser ceiling microphone. It can be fixed on the rotating steel holding spring and suspended from the ceiling or in a high position sweet spot to pick up the sound of a choir or orchestra. It offers 3 inter-changeable capsules to meet different applications. It has a 10-meter microphone cable with TA3F connector between the capsule and power adapter.

- Inter-changeable 3 capsules to meet different applications
- Inconspicuous ceiling installation
- 10-meter (33') TA3F microphone cable included

E308B black  
E308W white



Inter-changeable capsules  
U: Cardioid capsule  
H: Supercardioid capsule  
O: Omni capsule

### Specifications



Type	Back electret, Ø16 mm (Ø0.63")
Polar Pattern	Cardioid / supercardioid / omni
Frequency Response	20-18,000Hz
Sensitivity	-44 dBV/Pa (6.3 mV)
Output Impedance	500 Ω
Min. Load Impedance	1,000 Ω
S/N Ratio	76 dB
Equivalent Output Noise	18 dB
Max. SPL	138 dB SPL
Dynamic Range	120 dB
Power Requirements	Phantom 12-52V DC, 4 mA
Finish	Black or white
Connector	TA3F
Dimensions	Capsule: Ø20 mm (Ø0.79"); cable: 10-meter (32.8')
Net Weight	300 g (10.6 oz)
Accessories Furnished	PS418S preamplifier, S20 windscreen, Steel holding spring, Pipe clip
Packaging	Colorful outer packaging

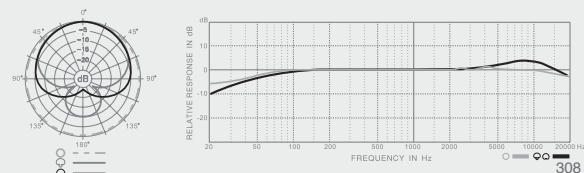

## PRA52

### Ceiling Microphone

Conference / House of Worship / Surveillance / Stage

The PRA52 is a miniature condenser ceiling microphone. It can be fixed on the rotating steel holding spring and suspended from the ceiling or in a high position sweet spot to pick up the sound of a choir or orchestra. It comes in black or white to meet different applications. There is a 10-meter microphone cable with XLR3M connector between the capsule and power adapter.

- High sensitivity
- Excellent sound pick up and RF immunity
- Phantom power needed
- 10-meter microphone cable with XLR3M connector

PRA52B black  
PRA52W white

### Specifications



Type	Back electret, Ø9.7 mm (Ø0.38")
Polar Pattern	Cardioid
Frequency Response	40-18,000 Hz
Sensitivity	-43 dBV/Pa (7.1 mV)
Output Impedance	600 Ω
Min. Load Impedance	2,000 Ω
S/N Ratio	70 dB
Equivalent Output Noise	24 dB
Max. SPL	132 dB SPL
Dynamic Range	108 dB
Power Requirements	Phantom 12-52V DC, 4 mA
Finish	Black or white
Connector	XLR3M
Dimensions	Ø12x27 mm (Ø0.47" x 1.06")
Net Weight	220 g (7.76 oz)
Accessories Furnished	S06 windscreen, Steel holding spring, Pipe clip
Packaging	Colorful outer packaging

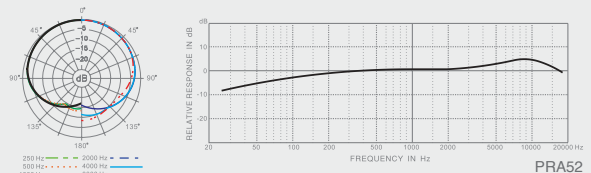



## D401S

### Omni Podcast Microphone

Podcaster / Interview / Speech Recording / Communication / Language Learning Classroom

The Superlux D401S is an omni directional, dynamic microphone with no proximity effect, and no coloration. It features uniform sensitivity and flat on-axis response to provide articulate speech for interview, broadcast, or podcast. It is very suitable for recording only application, so there is no feedback concern or coloration.

Sleek profile for comfortable handling, visual effect and suppressed wind noise.

- Omni directional, uniform sensitivity, balanced and natural sound.
- Low impedance, high dynamic range
- Spherical pick-up, capturing all related message, consistent output signal when in long term use
- Strengthened metal grille, sturdy die-cast shaft for maximum impact protection

### Specifications

Type	Dynamic
Polar Pattern	Omni
Frequency Response	80-15,000 Hz
Sensitivity	-54 dB (2 mV)
Output Impedance	200 Ω
Min. Load Impedance	1,000 Ω
Max. SPL	135 dB SPL
Finish	Titanium grey
Connector	XLR3M
Dimensions	Ø47 × 174 mm (Ø1.85" × 4.33")
Net Weight	280 g (9.9 oz)
Accessories Furnished	HM38S mic clip with screw knob, YA2 threaded adapter
Packaging	White box

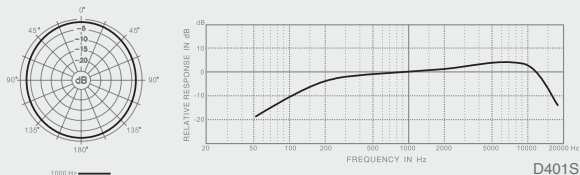

## PRA535

### Push to Talk Microphone

Emergency / Communication / Transportation / Airplane / Noisy and Traveling Environments

The PRA535 serial microphone has push to talk function with excellent attenuation of the ambient noise. The PRA535 is a noise cancel type, the PRA535NC is an ultra noise cancel type, both built-in 3.4-meter coil spring output cable.

- Push to talk switch
- Excellent in clearness of speech recognition and intelligibility
- Excellent attenuation of ambient noise
- Premium durability to high temperature, humidity, vibration and dropping
- Corrosion-resistant body (against oil, acid, and alkali)

PRA535	6.3 mm TS connector, noise cancelling
PRA535NC	Pigtail, ultra noise cancelling
PRA535NC/P	6.3 mm TS output connector, ultra noise cancelling

### Specifications

Type	Dynamic
Polar Pattern	Omni
Frequency Response	100-5,000 Hz
Sensitivity	-66 dBV/Pa (0.5 mV)
Output Impedance	200 Ω
Min. Load Impedance	1,000 Ω
Max. SPL	145 dB SPL
Finish	Black
Connector	Pigtail or 6.3 mm (1/4")
Dimensions	67 × 94 × 50 mm (2.64" × 3.7" × 1.97")
Net Weight	250 g (8.8 oz)
Accessories Furnished	Wall bracket
Packaging	White box

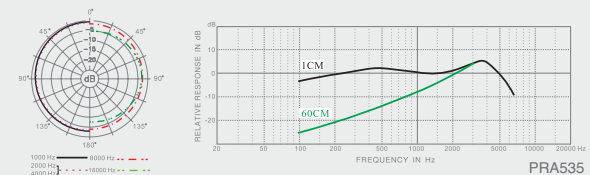



## PRA535NC

### Push to Talk Microphone

Emergency / Communication / Transportation / Airplane / Noisy and Traveling Environments

The PRA535 serial microphone has push to talk function with excellent attenuation of the ambient noise. The PRA535 is a noise cancel type, the PRA535NC is an ultra noise cancel type, both built-in 3.4-meter coil spring output cable.

- Push to talk switch
- Excellent in clearness of speech recognition and intelligibility
- Excellent attenuation of ambient noise
- Premium durability to high temperature, humidity, vibration and dropping
- Corrosion-resistant body (against oil, acid, and alkali)

PRA535	6.3 mm TS connector, noise cancelling
PRA535NC	Pigtail, ultra noise cancelling
PRA535NC/P	6.3 mm TS output connector, ultra noise cancelling



## PRA448

### Flush Mount Microphone

Warehouse / Factory / School / Restaurant / Fast Food Stores / Apartment / Security Access

The PRA448 dynamic microphone is specially designed for flush mount on a wall. It can be used both indoors and outdoors and comes with a stainless steel plate, standard gauge box plate size for easier installation, a DPDT push switch for momentary on/off.

- Clear voice
- Standard gauge box plate size
- DPDT ON/OFF switch (PRA448S)

PRA448S	with ON/OFF switch
---------	--------------------

### Specifications

Type	Dynamic
Polar Pattern	Omni
Frequency Response	100-5,000 Hz
Sensitivity	-66 dBV/Pa (0.5 mV)
Output Impedance	200 Ω
Min. Load Impedance	1,000 Ω
Max. SPL	145 dB SPL
Finish	Black
Connector	Pigtail or 6.3 mm (1/4")
Dimensions	67 × 94 × 50 mm (2.64" × 3.7" × 1.97")
Net Weight	250 g (8.8 oz)
Accessories Furnished	Wall bracket
Packaging	White box

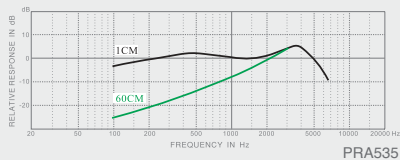
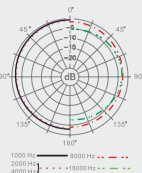

### Specifications

Type	Dynamic
Polar Pattern	Omni
Frequency Response	150-4,500 Hz
Sensitivity	-45 dBV/Pa (7.9 mV)
Output Impedance	500 Ω
Min. Load Impedance	2,000 Ω
Max. SPL	135 dB SPL
Finish	Stainless steel
Connector	Pigtail
Dimensions	115 × 70 × 33 mm (4.53" × 2.76" × 1.3")
Net Weight	80 g (2.8 oz)
Packaging	White box

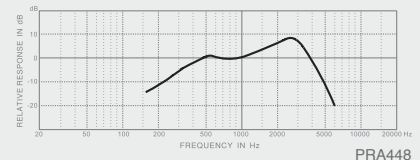
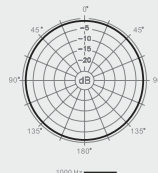

# **Conference System & Measurement**

# Conference System Intercom Series



## IS103 Intercom Set

**Broadcast Sporting Events / Cable Access Television / Houses Of Worship / Educational Institutions**

The IS103 is a complete wired intercom system that serves the production communication needs of video and film, broadcast sporting events, cable access television, houses of worship, and educational institutions. The IS103 is a one-channel wired intercom system, consisting of a power supply, 2 belt packs, a compact main station, a rack mounting kit and 3 intercom headsets. And the system connections are made via standard 3-pin XLR cables.

- Supports up to 4 wired users with BP101
- Light and sound alert
- Excellent intelligibility and sound quality

IS103 intercom set includes:

- 1 main station CS101
- 2 belt-pack BP101
- 1 power supply PS101
- 3 headsets HMD685a
- 1 rack mounting kit RK101



## IS103A Intercom Set

**Broadcast Sporting Events / Cable Access Television / Houses Of Worship / Educational Institutions**

The IS103A is a complete wired intercom system that serves the production communication needs of video and film, broadcast sporting events, cable access television, houses of worship, and educational institutions. The IS103A is a one-channel wired intercom system, consisting of a power supply, 2 belt packs, a compact main station, a rack mounting kit and 3 intercom headsets. And the system connections are made via standard 3-pin XLR cables.

- Supports up to 10 wired users with BP101
- Light and sound alert
- Excellent intelligibility and sound quality

IS103A intercom set includes:

- 1 main station CS101A
- 2 belt-pack BP101
- 1 power supply PS101A
- 3 headsets HMD685a
- 1 rack mounting kit RK101



## BP101

### Belt Pack

Broadcast Sporting Events / Cable Access Television / Houses Of Worship / Educational Institutions

The belt pack BP101 is a portable 1-channel intercom station and can be connected with CS101 compact station through the power supply PS101. The integrated belt clip allows for easy fixing the unit to clothes. On the rear of the unit all XLR connectors are easily accessible. The side tone is adjustable. The BP101 features light and sound alarm. The sound alarm is switchable.

#### Specifications

Frequency response	20-20,000 Hz
Signal to noise ratio	≥ 85 dB
Impedance	200 Ω
Connectors	3 and 4 pin XLR
Finish	black
Dimensions	122 × 85 × 50 mm
Net Weight	330 g (11.6 oz)
Packaging	Colorful outer packaging



## HMD685a

### Single Ear Intercom Headset

Sports Commentators / News Presenters / Podcasting / Conferencing / Intercom / Camera Use

The HMD685 and HMD685a are professional intercom headsets with flexible anti-vibration gooseneck boom microphones. They apply to requirements of demanding broadcast applications for studio or outside productions. The headset is lightweight, provides extra soft ear cushions and headband paddings for outstanding wearing comfort even during extra soft ear cushions headset is provided with a dynamic vocal unidirectional patterned microphone, featuring excellent acoustic performance and a reliable noise suppression.

- Lightweight with extra soft cushions for comfort fit
- Accurate and linear sound reproduction for professional Radio and TV applications
- Microphone provides audio transmission in broadcast quality
- Reliable performance ensures long lifetime use
- Folding design for easy storage

#### Specifications

Headphone	
Transducer principle	Dynamic, closed
Ear coupling	Circumaural
Frequency response	20-20,000 Hz
Impedance	400 Ω
Sensitivity	96 dB at 1 kHz, 1 mW
Max. Input Power	100 mW
Microphone	
Transducer principle	Dynamic
Polar Pattern	Cardioid
Frequency response	50-15,000 Hz
Sensitivity	-64 dBV/Pa (0.6 mV/Pa) at 1 kHz
Impedance	250 Ω
Finish	Black
Dimensions	H210 x W175 mm
Net Weight	342 g (12.06 oz)
Packaging	Colorful outer packaging

# Measurement Microphone



## ECM999

### 1/2" Measurement Microphone

#### Measurement / Recording

The ECM999 is an omni-directional microphone for free-field measurement with built-in highly-reliable circuit, 1/4" pre-polarized condenser capsule, high stability, low distortion, and less noise in performance. Its excellent flat frequency response makes it an ideal candidate for sonic analysis systems and for special recording as well.

- Sturdy metal construction, durable black finish
- Very flat response, excellent electro-acoustic characteristics
- Ideal for room sonic analysis systems, measurement, testing and recording
- Powered by phantom power 12-52V DC
- Standard 1/2" measurement diameter

#### Specifications



Type	Back electret, Ø6 mm (Ø0.24")
Polar Pattern	Omni
Frequency Response	20-20,000 Hz
Sensitivity	-37 dBV/Pa (14 mV)
Output impedance	200 Ω
Minimum Load Impedance	1,000 Ω
S/N Ratio	70 dB
Equivalent Output Noise	24 dB
Max. SPL	132 dB SPL
Dynamic Range	108 dB
Power Requirements	12-52V DC, 2 mA
Finish	Black
Connector	XLR3M
Dimensions	Ø21 x 192 mm, Ø0.83" x 7.56"
Net Weight	140 g (4.9 oz)
Accessories Furnished	HM10S mic clip with screw knob, YA2 threaded adapter, S02 windscreen
Packaging	A1 carrying case, colorful outer sleeve

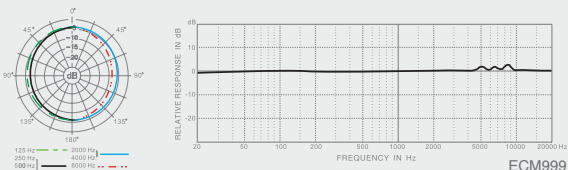

## ECM888B

### 1/4" Measurement Microphone

#### Measurement / Recording

The ECM888B is a 1/4" standard measurement microphone powered by an internal battery. There is no external power needed for easier connection to various devices such as a real time analyzer, PC, or palm-size devices. Its wide and flat frequency response makes the ECM888B an ideal measurement and recording microphone.

- Metal structure with champagne silver finish
- Wide frequency response from 20 Hz to 20 kHz
- Suitable for spectrum analyzer, audio testing and measurement applications
- Internal battery, 6V 4LR44 battery
- 1/4" industrial standard diameter

#### Specifications



Type	Back electret, Ø6 mm (Ø0.24")
Polar Pattern	Omni
Frequency Response	20-20,000 Hz
Sensitivity	-48 dBV/Pa (4 mV)
Output Impedance	800 Ω
Minimum Load Impedance	3 kΩ
S/N Ratio	72 dB
Equivalent Output Noise	22 dB
Max. SPL	132 dB SPL
Dynamic Range	110 dB
Power Requirements	6V 4LR44, 0.5 mA, >200 hours
Finish	Champagne silver
Connector	XLR3M
Dimensions	Ø21 x 170 mm, Ø0.83" x 6.7"
Net Weight	150 g (5.3 oz), without battery
Accessories Furnished	HM32 shock mount, YA2 threaded adapter, 4LR44 battery
Packaging	A1 protective carrying case, colorful sleeve

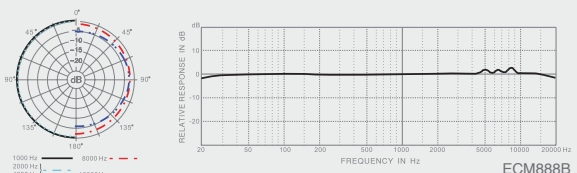



## E302 Mini Test Microphone

Home Theater / PC / Notebook

Omni measurement microphone is especially designed for home theater automatic alignment setting. Permanent attached cable with 3.5 mm stereo plug. It's suitable for popular plug-in power mic inputs and simple to use.

- Sturdy metal construction, black finish
- Very flat response, excellent electro-acoustic characteristics
- Ideal for home theater automatic alignment setting
- Permanent attached 8-meter cable 3.5 mm stereo plug, wired as mono

### Specifications



Type	Back electrets, Ø6 mm (Ø0.24")
Polar Pattern	Omni
Frequency Response	20-20,000 Hz
Sensitivity	-42 dBV/Pa (7.94 mV)
Output Impedance	2.2 kΩ
Power Requirements	3-9V DC, 0.5 mA
Finish	Black
Connector	1/8" (3.5 mm) stereo mini plug, wired as mono, 8-meter cable
Dimensions	Ø21 x 128.5 mm, Ø0.83" x 5.1"
Net Weight	180 g (6.3 oz)
Accessories Furnished	DS01 table stand, HM9A mic clip
Packaging	White box

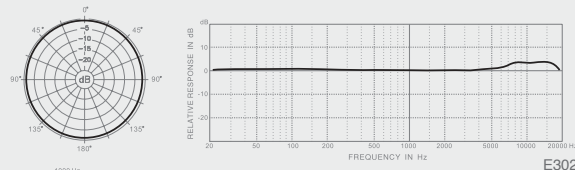

E302



## PINK STICK Signal Generator

Measurement / Recording

The Pink Stick is a random noise generator with built-in XLR-3M connector. It can be directly plugged into the microphone pre-amplifier which provides phantom power, so no battery is needed. Its rotary switch selects between pink noise, 1 kHz tone, and pulse tone and there is mute setting in between every signal for easy protection.

- Built-in pink noise, 1kHz, and pulse tone
- Extremely compact size
- Integral XLR3M connector for direct plug-in to the microphone preamplifier
- Phantom powered
- No batteries required
- Mute setting in between every signal for easy protection

### Specifications

Type	Balanced mic level output
Noise Pattern	Pink noise, 1 kHz, pulse
Output Level	Pink noise: -14 dBu, 1 kHz: -4.5 dBu, Pulse: -29 dBu
Power Requirements	48V DC phantom
Finish	Champagne silver
Connector	XLR3M
Dimensions	Ø22 x 110 mm, Ø0.89" x 4.35"
Net Weight	120 g (4.2 oz)
Packaging	Plastic locket



## ECM999U

### USB Measurement Microphone Set

#### Measurement / Recording

The ECM999U is an omni-directional microphone for free-field measurement, inheriting the professional-grade performance of the ECM999. With a USB Type-C interface, it is plug-and-play without the need for phantom power or an additional audio interface. It features a 1/4" pre-polarized condenser capsule and a highly reliable built-in circuit, ensuring high stability, low distortion, and low noise performance. Its exceptionally flat frequency response makes it an ideal choice for acoustic analysis, measurement, and special recording applications.

- USB Type-C connectivity, plug-and-play, no additional audio interface or phantom power required
- Sturdy metal construction, solemn black finish, durable and resistant to interference
- Extremely flat frequency response, providing professional-grade acoustic measurement accuracy
- Ideal for room sonic analysis, measurement, testing, and recording, compatible with various measurement software
- Standard 1/2" measurement diameter, widely applicable in professional testing environments

#### Specifications



Type	USB Measurement Microphone
Polar Pattern	Omni
Frequency Response	10-20,000 Hz
Sensitivity	-38 ± 2 dBV/Pa
Max. SPL	133 dB
Bit rate	24 bit
Sampling rate	48 kHz
Power Supply	USB 5V
Finish	Black
Connector	Type – c
Dimensions	Ø21 × 181 mm (Ø0.83" × 7.12")
Net Weight	142 g (5 oz)
Compatibility	Win10, Win11, Mac
Accessories Furnished	DS01 Table Stand, HM10S MIC Clip, S02 Windscreen, 2-meter USB Cable
Packaging	Storage bag, colorful outer sleeve

# Wireless Systems



## UK82

### Professional Manufacturer Of Entertainment Vocal System

#### School Classroom / KTV

UK82 features digital frequency-hopping spread spectrum (FHSS) technique. With up to 200 selectable frequencies across 50MHz bandwidth under 250k channel spacing. UK82 allows multi-sets of systems to work at the same time without interference.

The special designed high-and-low power switch function not only provides the smooth transmission in high-power transmission occasions (like gathering place) but also is able to save the battery power in low-power transmission occasions (like classroom or KTV room).

- UK82 is equipped with UHF ultra-high frequency range to provide less interference than the traditional VHF frequency range and provide higher fidelity and more reliable transmission
- UK82 features digital frequency-hopping spread spectrum (FHSS) technique. With up to 200 selectable frequencies across 50MHz bandwidth under 250k channel spacing. UK82 allows multi-sets of systems to work at the same time without interference
- The advanced automatically frequency pairing technology enables the transmitter to target the channel automatically by just pressing the button even if the frequencies of the transmitter and the receiver are not matched
- The special designed high-and-low power switch function not only provides the smooth transmission in high-power transmission occasions (like gathering place) but also is able to save the battery power in low- power transmission occasions (like classroom or KTV room)
- The unique locking function of the receiver avoids misoperation
- High quality LCD screen to provide clear understanding of the working status

#### Specifications

Modulation Type	FM + Digital Auxiliary Channel
S/N	95 dB (A-weighted, 1 KHz 1%)
THD	0.57% 1KHz
Max. SPL	130 dB
Operation Distance	50 m (Outdoor, within visual range)
Numbers of Channel	100 Channels for A, B Channel each
Audio Frequency Response	80 Hz-16 kHz
Carrier Frequency Range	A ch 640-664.75 MHz / B ch 665-689.75 MHz
Receiver Sensitivity	-95 dBm
Receiver Power Supply	AC 100-240V D12V 2000 mA
Transmitter Current	125 mA @ 3 V
Transmit RF Power	<13 dBm
Transmitter Power Supply	2'AA
Packaging	Colorful outer packaging



## UK3

### Handheld Wireless Microphone

#### School Classroom / KTV

The brand-new UK3 handheld wireless microphone crystal-clear audio quality and seamless transmission. Stepping onto the stage, every word and sentence holds its unique value. Specifically designed for these special moments, we are proud to introduce the brand-new UK3 handheld wireless microphone, equipped with UHF fixed-frequency circuitry, it ensures that every word you speak is transmitted with unmatched clarity and stability.

Forget the tedious setup process. The UK3 operates on a fixed frequency, eliminating the hassle of frequency matching. Simply turn it on, and you're free to use it as you wish.

UK3 is more than just a microphone; it embodies the perfect blend of professionalism, convenience, and efficiency. Whether for business meetings or small events, it ensures that your voice is precisely delivered to every listener. Choose UK3, and experience the perfect harmony of audio quality and freedom. Let's work together to make sure your voice is perfectly captured and transmitted, anytime and anywhere.

- Provides clear audio transmission, ensuring every word and sentence from the user is perfectly conveyed.
- Utilizes digital pilot tone technology, offering more stable transmission and significantly reducing the possibility of interference.
- Eliminates the need for complex frequency matching, ready to use with a simple push of a button.
- Versatile: Suitable for a range of occasions, from professional business meetings to small events, always ensuring optimal audio quality.

#### Specifications

Modulation Type	FM + Digital Auxiliary Channel
S/N	90 dB (A-weighted, 1 KHz)
THD	0.2% 1 KHz
Operation Distance	50 m
Numbers of Channel	1 Channels
Audio Frequency Response	80 Hz - 16 kHz
Carrier Frequency Range	642 MHz
Receiver Sensitivity	-95 dBm
Receiver Power Supply	AC 100-240 V DC 12V $\approx$ 1000 mA
Monitor	LED
Packaging	Colorful outer packaging

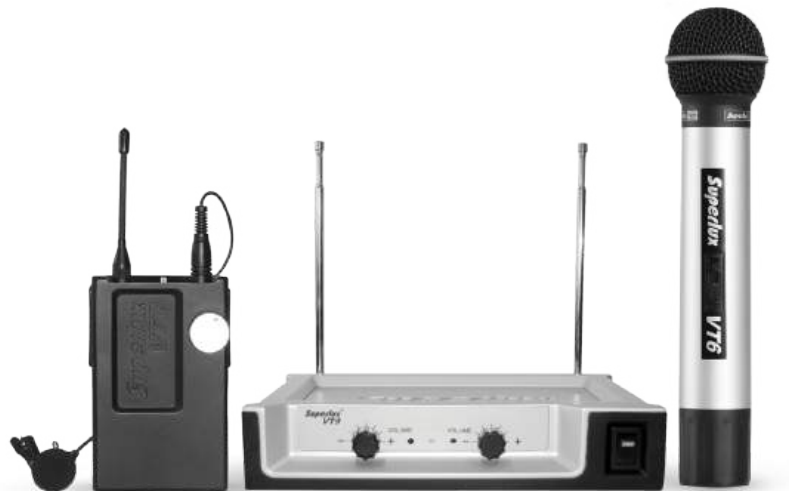

VT7

VT9

VT6

## VT9

### Practical Wireless System

#### Family Karaoke / PA

The VT9 Series wireless system is built for karaoke and general PA applications. This system has been carefully designed to ensure that a clear and warm vocal will be reproduced and has a highly steady wireless system within effective operating distance. This series is the most popular for installation in karaoke boxes, school teaching, speech, and night club applications.

- Quartz oscillation fixed frequency Receiver, no need to match the channel
- Frequency range: 170 MHz-250 MHz
- HF with multiple narrow-band and MF with selected filter to minimize the interference of hash
- Low voltage working design, battery powered handheld transmitter works even when voltage is lowered to 5V
- ALC circuitry protects microphone from high sound pressure, low distortion
- Eliminate unwanted pulse noise design while turning ON or OFF transmitter
- Quartz oscillation mode to ensure ultra-stability
- Advance compander circuitry reduces noise and increases dynamic range
- Feedback eliminator to increase the maximum feedback level
- Independent output and mixed output

VT96 handheld system includes:

- 1 VT9 Receiver
- 2 VT6 Handheld transmitters

VT97 / 12A lavalier system includes:

- 1 VT9 Receiver
- 2 VT7 Bodypack transmitters
- 2 E12A / 3.5 mm plug lavalier microphones

VT97 / 10B headworn system includes:

- 1 VT9 Receiver
- 2 VT7 Bodypack transmitters
- 2 E10B / 3.5 mm plug headworn microphones

VT967 / 12A Handheld & Lavalier System includes:

- 1 VT9 Receiver
- 1 VT6 Handheld transmitter
- 1 VT7 Bodypack transmitter
- 1 E12A / 3.5 mm plug lavalier microphone

VT967 / 10B Handheld & Headworn System includes:

- 1 VT9 Receiver
- 1 VT6 Handheld transmitter
- 1 VT7 Bodypack transmitter
- 1 E10B / 3.5 mm plug headworn microphone

VT97 / 12A + 10B Lavalier & Headworn System includes:

- 1 VT9 Receiver
- 2 VT7 Bodypack transmitters
- 1 E12A / 3.5 mm plug lavalier microphone
- 1 E10B / 3.5 mm plug headworn microphone

#### Specifications

Carrier Frequency	VHF 170-250 MHz
Frequency Response	80 Hz-15,000 Hz
Frequency Stability	± 0.005%
S/N Ratio	>70 dB
Total Harmonic Distortion	<0.5% (1,000 Hz)
Channel numbers	2
Operating Range	40 meters in open area

#### Specifications

#### VT9 Receiver

Squelch Control	Noise Lock
Receiving Sensitivity	-80 dBm
False Image Interfere Rate	≥ 80 dB
Power Requirement	AC 100-240 V DC 12V === 300 mA
Output Type	Separate or mixed output

#### Specifications

#### VT6 Handheld & VT7 Bodypack Transmitters

Indicator	Green: battery enough; Red: battery low
Frequency Deviation	±23 kHz
Stability	±0.005 %
Modulation	FM
Transmission Power	≤10 mW
Power Requirement	9V tier battery (VT6); 2 x 1.5V AA battery (VT7)

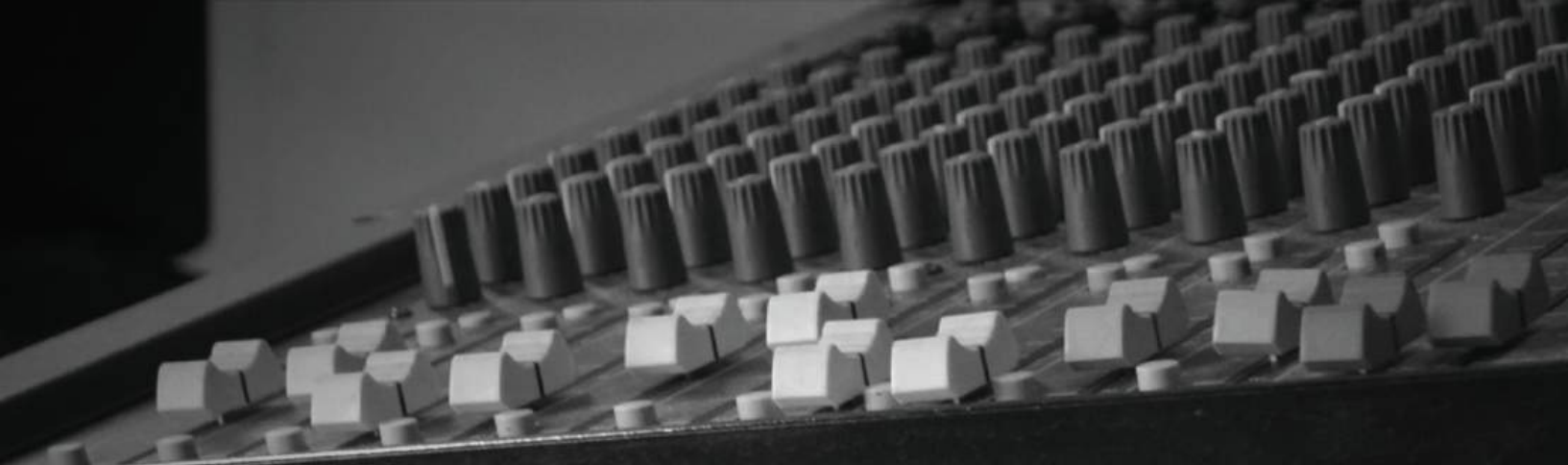

# **Microphone Accessories**

# Preamplifiers, Phantom Power Supplies



## PS418D Pre-Amplifier

The condenser miniature microphones, for example, PRA383, E308, PRA30, and WU518, need phantom power to work. The PS418D is just what they need. It can be powered by phantom power or battery, and switchable low cut filter helps to reduce low band noise.

- Two options for Power Requirements: phantom or battery
- Low-cut filter switch
- Transistor output transformer circuit

### Specifications

Frequency Response	25-20,000 Hz
Output Impedance	Phantom: 200 Ω, Battery: 270 Ω
Min. Load Impedance	1,000 Ω
Power Requirements	Phantom: 9-52V DC, 2 mA, Battery: 1.5V AA/UM3
Low Frequency Filter	80 Hz @ 12 dB / oct
Connector	TA3M (input); XLR3M (output)
Dimension	W63 x H84 x D22.5 mm (W2.48" x H3.3" x D0.89")
Net Weight	245 g (9.9 oz)
Packaging	White box



## PS418S Pre-Amplifier

The PS418S provides a pre-amplifier to miniature microphones, such as PRA383, E308, PRA30, and WU518 that have tiny inline design minimized space requirements. The PS418S is necessarily powered by phantom supply.

- Low profile design
- Phantom power needed

### Specifications

Frequency Response	25-20,000 Hz
Output Impedance	200 Ω
Min. Load Impedance	1,000 Ω
Power Requirements	9-52VDC, 2 mA
Connector	TA3M (input); XLR3M (output)
Dimensions	Ø21 x 106 mm (Ø0.83" x 4.18")
Net Weight	118 g (4.2 oz)
Packaging	White box



## PS2A Phantom Power Supply

The PS2A is a 48V dual channel phantom power supply. It widens the microphone output's dynamic range and produces more output gain. It operates with an auto power source ranging from 110V AC to 230V AC.

- The PS2A phantom power unit can be used to power 2 condenser microphones or a pair of stereo condenser microphones
- Low undulation and background noise output (lower than common mixer's phantom unit around -12 dB), it is the best for recording
- The PS2A fits any 48V condenser microphone, it presents low noise natural true sound

### Specifications

Power Requirements	AC 110-230V (50-60 Hz)
DC Output	48 ± 2V
Signal Separability	≥ 95 dB
Current Output	Max. 2 × 6.5 mA (short circuit)
Undulatory Voltage	≤ 0.15 mV
Power Consumption	2 W
Connector	XLR
Dimensions	W160 × H55 × D130 mm (W6.3" × H2.2" × D5.1")
Net Weight	1.4 kg (3.1 lbs)
Accessories Furnished	Power cord
Packaging	White box



## PS2B Phantom Power Supply

The PS2B provides both 12V and 48V output voltage, powered by two 9V batteries or 12V DC output AC adapter (option). It is very convenient and reliable for either indoor or outdoor use.

- Powered by two 9V batteries or 12 VDC adapter (option)
- Supply power to 2 microphones simultaneously
- 3-position switch (12V / OFF / 48V): 48V for microphones with working voltage between 24V- 48V; 12V for microphones with lower voltages
- Low-noise circuit design

### Specifications

Power Requirements	Two 9V (1604A) batteries or 12V DC adapter (Optional)
Connectors	Input: 2 XLR3F, Output: 2 XLR3M
Dimensions (with foot pads)	155 × 57 × 108 mm (6.1" × 2.2" × 4.3")
Weight (with batteries)	650 g (22.9 oz)
Accessories Furnished	2 × 9V (1604A) batteries
Packaging	Colorful outer packaging



## CP818

### Impedance Converter

- XLR3F-1/4" (6.3 mm) TS
- Permits use of longer microphone cables
- Maintains high-frequency response
- Reduces noise pickup
- Convert low impedance to high or versa

#### Specifications

Input Impedance	250 Ω (nominal)
Output Impedance	50,000 Ω (nominal)
Frequency Response	20-20,000 Hz



## CP828

### Impedance Converter

- XLR3M-1/4" (6.3 mm) TS
- Permits use of long microphone cables
- Maintains high-frequency response
- Reduces noise pickup
- Simple DI suitable for electric guitar, electric bass, electric violin, keyboard and sending signal to the mixer
- Convert low impedance to high or versa

#### Specifications

Input Impedance	250 Ω (nominal)
Output Impedance	50,000 Ω (nominal)
Frequency Response	20-20,000 Hz



## CP838

### Impedance Converter

- XLR3M-1/4" (6.3 mm) TS socket
- Permits use of long microphone cables
- Maintains high-frequency response
- Reduces noise pickup
- Perfectly matched by connecting to Superlux D112 Harmony microphone (the TS connector should plug into the low impedance microphone input for better results)
- Convert low impedance to high or versa

#### Specifications

Input Impedance	250 Ω (nominal)
Output Impedance	50,000 Ω (nominal)
Frequency Response	20-20,000 Hz

## Pop Filters



Microphone is not included



## HM20

### Metal Mesh Pop Filter

The HM20 Professional Pop Filter eliminates plosives and protects your microphone from saliva. Constructed from long-lasting stretched mesh steel, the metal mesh perforations direct plosive energy downward and away from the microphone capsule. It's easy to clean, and includes 12" gooseneck and 5/8" threaded screw mounting bracket. It is compatible with most mic mounts and tripod stands.

- Ø127.5 mm (Ø5") metal pop screen
- Long lasting stretched mesh steel construction
- Metal mesh perforations direct plosive energy downward about 30 dB
- Easy to clean
- 12" gooseneck and 5/8" threaded screw mounting bracket included

## HM43

### Metal Mesh Pop Filter

The HM43 is a high quality, professional metal pop filter for Superlux S241 studio condenser microphone. The clip can hold the S241 steadily, it is also suitable for Ø20-22 mm condenser microphones.

- The HM43 is the pop filter for Superlux S241 condenser microphone
- Metal pop filter with a Ø70 mm diameter
- It also suitable for microphones with a diameter between 20-22 mm
- Easy to clean

## HM18AG

### Professional Pop Filter (2 screens)

The HM18AG (2 screens) is a professional double layer pop filter. It includes 2 screens: metal mesh and nylon fabric. With a 5/8" threaded adapter, the HM18AG can be mounted on a microphone stand to protect the microphone from explosive pop sound. It will not affect high frequency response.

- It includes double layer metal mesh and double layer nylon fabric
- 5/8" threaded adapter
- Easy to mount on microphone stand

## HM91

### Large Diameter Double Layer Filter

The HM91 is a professional pop filter. It includes double layer filters with Ø185 mm. The bracket pad can protect the microphone from scratches. Its gooseneck diameter is Ø8.5 mm, filter frame Ø185 mm (Ø7.28") and net weight is 0.45 kg (0.9 lbs).

- Double layer filter
- Ø185 mm (Ø7.28") nylon pop screen
- Bracket pad protects the microphone from scratches

# General Microphone Clips



**HM8**  
Adapter

CMH8 serial large diaphragm condenser microphone adapter (M22 x 1.0), YA2 threaded adapter included.

HM8 Champagne silver  
HM8B Black



**HM9**  
Mic Clip

For Ø20-35 mm microphone.

HM9A with plastic thread (5/8")  
HM9B with metal thread (5/8")



**HM10**  
Mic Clip

For Ø19-24 mm microphone.

HM10A with plastic thread (5/8")  
HM10S with screw knob and metal thread (5/8")



**HM16**  
Mic Clip

For Ø23-30 mm microphone.

HM16B with metal thread (5/8")  
HM16S with screw knob and metal thread (5/8")



**HM29**  
Wireless Mic Clip

For Ø29-39 mm wireless microphone.

HM29B with metal thread (5/8")  
HM29S with screw knob and metal thread (5/8")



**HM37**  
Mic Clip

For Ø18-20 mm microphone.

HM37B with metal thread (5/8")  
HM37S with screw knob and metal thread (5/8")



**HM38**  
Mic Clip

For Ø24-26 mm microphone.

HM38B with metal thread (5/8")  
HM38S with screw knob and metal thread (5/8")



**HM39**  
Wireless Mic Clip

For Ø32-38 mm wireless microphone.

HM39B with metal thread (5/8")  
HM39S with screw knob and metal thread (5/8")



**HM42**  
Mic Clip

For Ø24-32 mm microphone.

HM42A with plastic thread (5/8")  
HM42B with metal thread (5/8")



**HM101A**  
Mic Clip

For Ø16-45 mm microphone, with metal thread (5/8").



**YA1 YA2 YA3**  
5/8"-3/8" Threaded Adapter

YA1 Copper  
YA2 Zinc alloy  
YA3 Plastic  
\*1 in 1 pack or 10 in 1 pack

**Model name code:**

Thread for Europe is Ø3/8", thread for US is Ø5/8"

A Clip with plastic thread (5/8")

B Clip with metal thread (5/8")

C Camera adapter

S Clip with screw knob and metal thread (5/8")

**Microphone clips**

Model	Diameter
HM8	CMH8 Exclusive
HM9	20-35 mm
HM10	19-24 mm
HM16	23-30 mm
HM29	29-39 mm
HM37	18-20 mm
HM38	24-26 mm
HM39	32-38 mm
HM42	24-32 mm
HM101B	16-45 mm

# Camera Microphone Mount Adapters



**YA10**  
Camera Mic Adapter

Adapter for camera mount microphone with hot-shoe locking screw and 5/8" metal thread.



**HM35C**  
Camera Mic Shock Mount

Suitable for Ø15-27 mm microphones mounted onto camera.



**HM40C**  
Camera Mic Shock Mount

Suitable for Ø12-30 mm microphones mounted onto camera.

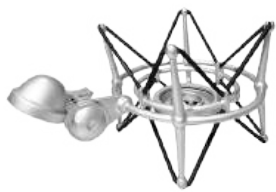

### HM56

#### Elastic Shock Mount

For E202, E205, E205U and E206 microphones.



### HM56B

#### Elastic Shock Mount

For E202, E205, E205U and E206 microphones.



### HM60

#### Elastic suspension shock mount

M22 × 1 thread. Elastic Shock mount for: L401U.



### HM61

#### Elastic suspension shock mount

M22 × 1 thread. Elastic Shock mount for: E431U.



### HM57

#### Elastic Shock Mount

M22 × 1 thread, 2 colors to choose from Champagne silver or black, YA2 threaded adapter included.

Elastic Shock mount for:  
CMH8A/B/C/D/G  
CMH8AH/BH/CH



### HM57E

#### Elastic Shock Mount

Elastic shock mount for microphone with M25 × 1 thread, dark green color, YA2 threaded adapter included.



### HM7

#### Elastic Shock Mount

M22 × 1 thread, Champagne silver color, YA2 threaded adapter included. Elastic shock mount is suitable for large diaphragm condenser microphone.

Elastic Shock mount for:  
CMH8A/B/C/D/G  
CMH8AH/BH/CH



### HM26A

#### Elastic Shock Mount

Elastic shock mount, YA2 threaded adapter included.

Elastic Shock mount for:  
CMH8A/B/C/D/G  
CMH8AH/BH/CH



### HM26B

#### Elastic Shock Mount

Elastic shock mount, YA2 threaded adapter included. Suitable for Ø22-26 mm microphone.



### HM26C

#### Elastic Shock Mount

Elastic shock mount, YA2 threaded adapter included. Suitable for HO8 microphone.



### HM31

#### Elastic Shock Mount

Shock mount is suitable for R102 & R102MKII ribbon microphone, YA2 threaded adapter included.



### HM30 / HM30S

#### Shock Mount

ID 20.4 mm, pipe length 40.5 mm, suitable for Ø20.8-24 mm microphones.

HM30S Shock mount for: S502, S502MKII, PRO218A, and PRA318L

#### Microphone clips

Model	Diameter or suitable microphones
HM7	CMH8 Series, except for CMH8K
HM32	20-26 mm
HM33	22-24 mm
HM35	15-27 mm
HM40	12-30 mm
HM40C	12-30 mm
HM54	24-40 mm

### HM33

#### Shock Mount

Suitable for Ø22-24 mm microphone, 5/8"-3/8" YA2 adapter included.

### HM35

#### Shock Mount

Suitable for Ø15-27 mm microphone, 5/8"-3/8" YA2 adapter included.

### HM32

#### Shock Mount

Suitable for Ø20-26 mm microphone, pipe can be extended from 54-76 mm, 2 ways to install rubber band, screw knob and YA2 threaded adapter included.



## HM40

### Shock Mount

Suitable for Ø12-30 mm microphone, 5/8"-3/8" YA2 adapter included, pipe length 90 mm.



- a** Elastic shock mount
- b** Acoustic arrangement
- c** Screw knob
- d** Metal thread



## HM54

### Shock Mount

Suitable for Ø24-40 mm microphone, pipe can be extended from 54-74 mm, 2 ways to install rubber band, screw knob and YA2 threaded adapter included.



- a** 2 ways to install rubber band, fits different diameters
- b** Pipe can be extended

## Dual microphone adapters



## C2

### Dual Mic Adapter

The distance between 2 microphones can be adjusted from 6-17 cm.



## HM15

### Dual Mic Adapter

The distance between 2 microphones is 17 cm for ORTF stereo recording mode, the diameter of 2 microphones clip adapter is 3/8", YA2 threaded adapter for mic stand included.



## MA90

### Stereo Recording Microphone Bar

MA90 is the best tool for A/B & ORTF stereo recording.  
 Length: 620 mm (24.4")  
 Net Weight: 0.64 kg (1.41 lbs)  
 Microphone angle detent every 15°

# Drum Clamps



## DMC01

### Drum Clamp

Clamps to drum rim, rod sticks, built-in 3/8" thread for microphone clip.



## DMC02

### Drum Clamp

Clamps to drum rim, rod sticks, built-in 3/8" thread for microphone clip.



## DMC03

### Drum Clamp

Clamps to drum rim, rod sticks, built-in 3/8" thread for microphone clip.



## HM12A

### Drum Clamp

Clamps to drum rim, rod sticks, built-in 5/8" thread for microphone clip.



## HM12E

### Drum Clamp

Clamps to drum rim, rod sticks, built-in 5/8" thread for microphone clip.



## HM12F

### Drum Clamp

Clamps on both ends attach to drum rim, rod sticks and microphone.



## HM12C

### Universal Clamp

Clamps on both ends of gooseneck attach to drum rim, rod sticks and microphone.



## HM12D

### Universal Clamp

Clamps on both ends of gooseneck attach to drum rim, rod sticks and microphone, built-in 5/8" thread for microphone clip.



## HM12G

### Drum Clamp

HM12G handlers are molded by elastic plastics, unlikely to deform, and they are adjustable for both wireless microphones of large diameter and taper microphones of small diameter. Rotatable within 180°. If applied with stands like HM12D or HM6, it will be even convenient to handle.



## HM25

### Drum Clamp

Clamps to drum rim, microphone clip attached, microphone height adjustable.

There are 3 models:

HM12C	80 mm
HM12CA	120 mm
HM12CB	160 mm

There are 5 models:

HM12D	80 mm
HM12DA	120 mm
HM12DB	160 mm
HM12DC	200 mm
HM12DD	300 mm

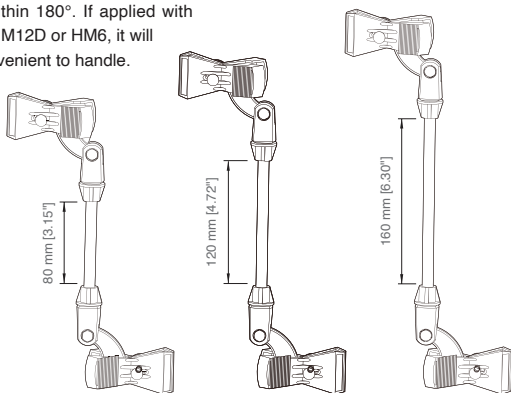

HM12C Series

HM12C

HM12CA

HM12CB

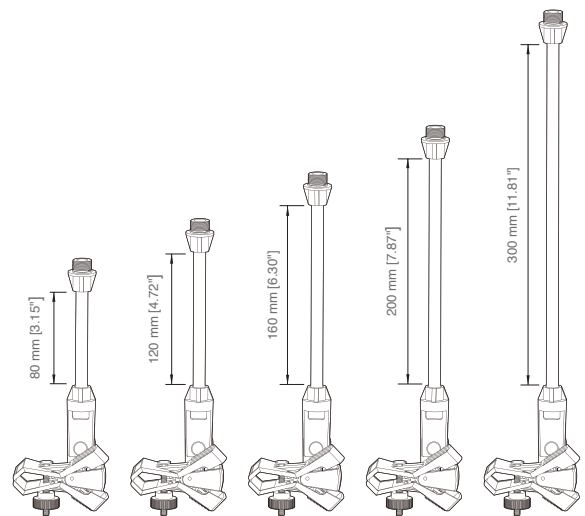

HM12D Series

HM12D

HM12DA

HM12DB

HM12DC

HM12DD

# Windscreens



## S02

### Measurement Mic Foam

Suitable for Ø7-10 mm microphone such as ECM999.



## S04

### Gooseneck Mic Foam

Suitable for Ø7-10 mm microphone such as PRA518.



## S05F

### Microphone Foam

Suitable for Ø6 mm microphone such as PRA528.



## S07F

### Microphone Foam

Suitable for Ø23 mm microphone such as PRA318L, PRA318S.



## S08F

### Pencil Type Mic Foam

Suitable for Ø20 mm microphone such as CMH8K.



## S09

### Instrument Mic Foam

Suitable for Ø23-30 mm microphone such as E124.



## S09F

### 1/2" Diaphragm Mic Foam

Suitable for Ø22 mm microphone such as S241.



## S11

### Headworn Mic Foam

Suitable for Ø10-18 mm microphone such as PRA20/30.



## S13F

### Lavalier Mic Foam

Suitable for Ø8 mm microphone such as WO (U) 518.



## S25

### XY Stereo Mic Foam

Suitable for E524D.



## S40

### Vocal Handheld Mic Foam

Suitable for Ø46-52 mm microphone. There are 5 colors to choose from: Black, Orange, Blue, Red, Yellow.



## S65

### Large Diaphragm Mic Foam

Suitable for Ø50-55 mm microphone such as CMH8 series.



## S14

### Shotgun Mic Foam

Suitable for Ø18-21 mm microphone, for example: PRA116B, PRA118S.



## S15

### Shotgun Mic Foam

Suitable for Ø18-21 mm microphone, for example: PRA118L.

### Specifications F indicates there is a frame inside the foam Unit: mm

Model No.	Inside diameter	Depth	Diameter	Microphone diameter	Suitable microphones	Color
S02	6	25	21	7-10	ECM999	Black
S04	6	31	25	7-10	PRA518	Black
S06	10	13	18	10-15	PRA52	Black, White
S07	21	55	46	22-30	PRA318S / L, E531	Black
S08F	20	19	35	20	CMH8K	Black
S09	22	52	46.5	23-30	E124	Black
S09F	22	36	46.5	22	S241	Black
S11	16	17	28	10-18	PRA20 / 30	Black
S12	8	5	11	8	WO(U)518	Black
S13	8	5	20	8	WO(U)518	Black
S14	17	260	43	18-21	PRA116B, PRA118S	Black
S15	17	390	43	18-21	PRA118L	Black
S18	20	52	38	21-29	PRA528DS	Black
S19	29	30	50	30-34	PRA538	Black
S20	18	30	45	19-25	E109	Black
S21F	12.5	28	27	12.5	E322, PRA528 Series	Black, White
S22F	12.5	36	35	12.5	E322, PRA528 Series	Black, White
S23	7	25	25	8-12	E10A, E10B	Black, Grey
S25	19	38	80x55x55	20-22	E524D	Black
S27	6	25	21	7-10	E102	Black
S32	21	150	45	21.5-23	E525S	Black
S33	21	295	45	21.5-23	E525L	Black
S40	50	60	55	46-52	Hand held vocal	Black, Blue, Orange, Red, Yellow
S50	35	71	70	35-55	E522, E523	Black
S53	5.5	16	23	6-9	E12A	Black
S55F	11	17.5	23	11.5-12	E309D PRO	Black
S56	15	45	33	16	E361	Black
S58	40	65	80	40-45	PRO238MKII	Black
S65	46	90	52	50-55	CMH8 Series	Black

# **Headphones & Headsets**



## HD660PRO

### Professional Studio Closed-Back Headphone

#### Recording Studio

HD660PRO is a professional closed-back dynamic headphone. With its neutral frequency response and extremely detailed sound the HD660PRO truly delivers pin point accuracy of instruments and vocals. Live performances sound excellent and powerful. "Natural and well-balanced sound profile" is the core characteristic of HD660PRO.

The flatter and wider high frequency response and lower distortion makes HD660PRO the perfect monitoring headphone for studio, post production and broadcasting application. HD660PRO is equipped with an improved headband design and softer velvet earpads to ensure listening comfort and fit during long term use. HD660PRO is available in 32Ω and 150Ω versions to satisfy different environment needs.

- Suitable for studio, monitoring or broadcast application
- 40 mm diameter driver
- Natural and well-balanced sound profile with low distortion
- Excellent sound isolation
- Ultra soft velvet earpads
- Features with 32 Ω and 150 Ω two versions to satisfy different environment needs
- Single-sided cable

#### Specifications

Driver	40 mm neodymium
Impedance	32 Ω & 150 Ω
Sensitivity	92 dB
Frequency Response	10 Hz-30 KHz
Connector	3.5 mm plug (Box included / 6.3 mm adapter)
Net Weight	325 g (11.46 oz)
Accessories Furnished	Soft carrying pouch, Screw-on gold-coated 3.5mm to 6.3mm stereo adapter



## HD330PRO

### Professional Semi-open Headphone

#### Recording Studio

HD330PRO is the circumaural, semi-open headphone which aims to attenuate ambient noise but allows the airflow generated by the vibration of the lamination to pass the well-designed grille hole on the earcup freely at the same time. It is suitable for most all kinds of the music. HD330PRO features with wide range frequency response and dynamic sound. Slightly forward sounding mids perfectly bring out the body and the emotion of vocals and instruments. Penetrating highs and bass deliver details and texture but not overstated.

HD330PRO gives you the "front row" sound image of the concert to enjoy the very rich sound while keep substantial spaces for precise soundstage between instruments. You will be pleased to be involved in the very intimate and engaging music experience of this headphone. HD330PRO is equipped with an improved headband design and softer velvet earpads to ensure wearing comfort and fit during long term use. HD330PRO is available in 32Ω and 150Ω versions to satisfy different environment needs.

- Solid bass, emotional mids, and bright, beautiful highs
- "Front row" experience for very intimate and engaging music experience
- Extraordinary wearing comfort and fit during long term use
- Features with 32Ω and 150Ω two versions to satisfy different environment needs

#### Specifications

Driver	40 mm neodymium
Impedance	32 Ω & 150 Ω
Sensitivity	93 dB
Frequency Response	10 Hz-30 KHz
Cable	2.5-meter (8.2 ft.)
Connector	3.5 mm plug (Box included / 6.3 mm adapter)
Net Weight	315 g (11.11 oz)
Accessories Furnished	Soft carrying pouch, Screw-on gold-coated 3.5mm to 6.3mm stereo adapter

# HD668BMKII

## Professional Studio Standard Headphones

### Recording Studio

The HD668B has been a classic in online forums for 15 years, earning the title of "King of Balanced and Authentic Sound." Building on this, Superlux introduces the HD668BMKII, which retains the classic design while adding innovative features for an enhanced listening experience. With a new diaphragm material, the HD668BMKII significantly improves sound resolution, delivering richer, more detailed audio. It maintains a neutral, balanced tuning with clear mids, smooth highs, and strong bass that doesn't overwhelm other frequencies.

The redesigned structure ensures a comfortable fit for long periods, whether you're working or relaxing. Lightweight and snug, it reduces pressure, making it ideal for extended wear. Combining professional sound quality with user-friendly operation, the HD668BMKII is perfect for both studio work and personal music enjoyment.

- Classic Redesign: Keeps the iconic HD668B look, adding new features
- Enhanced Sound: New diaphragm material for improved sound clarity and detail
- Balanced Tuning: Clear mids, bright highs, and deep bass without overpowering
- Comfort Fit: Lightweight, redesigned for extended comfort
- User-Friendly: Professional sound with simple, intuitive controls for any use

### Specifications

Types	Dynamic, Semi-open
Driver	Ø50 mm, Neodymium
Sensitivity	98 dB SPL (1 mW)
Frequency Response	10-30,000 Hz
Max. Input Power	300 mW
Rated Impedance	56 Ω (Copper-coated aluminium wire)
Ear Pads	High-quality protein PU leather earmuffs
Cables	Separate connection cable, Ø3.5x1.5 m
Connector	3.5 mm gold-plated to 6.3 mm
Caliper Pressure	Approx. 4.5 N
Finish	Black
Net Weight (without cable)	260 g (9.17 oz)
Accessories Furnished	1/4" (6.3mm) adapter, 1.5M straight cable, Carrying pouch



1. Adjustable headband design allows vertical sliding with a press.
2. Ear pads, 1 pair.
3. Detachable cable insert and rotate to align with the 'lock' symbol to secure.

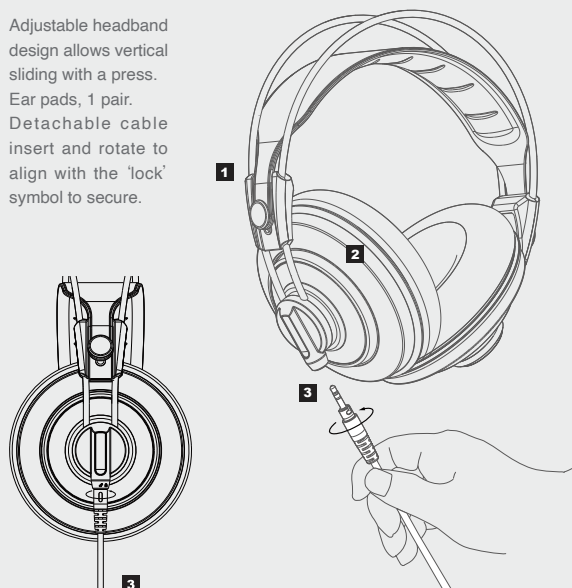



## HD687

### Semi-Open Type Headphone

Classic Music / POP Music / Rock Music

Equipped with the tailored ultra-high precision triple-layer diaphragm in order to reproduce the nature sound with less sound coloration and more balanced sound field. You are able to catch the clear resolution of each part and open sound field especially for the elasticity and the lasting charm of the bass instrument which is perfect for pop and rock.

- Semi-open, Circumaural
- Very suitable for classic music appreciation
- Tailored ultra-high precision double-layer diaphragm design
- Low distortion, keeping high sound quality
- Detachable single side design
- 40 Ω impedance to provide best use with portable device which can also be used with the high-definition headphone amplifier system

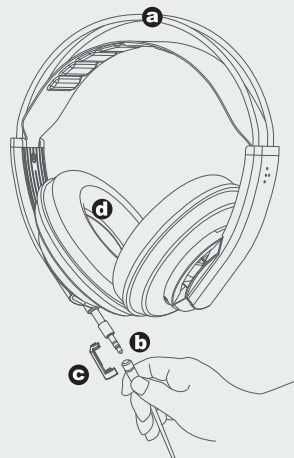

- a** Self-adjusting headband
- b** Detachable
- c** Cable clip
- d** Ear pads

Ear Pad Kit EPK687 is for HD687 and HD688 headphone. Each kit includes a pair of earpad and a pair of foam disks.

#### Specifications

Type	Dynamic, Semi-open
Driver	Ø51 mm, neodymium
Sensitivity	92 dB SPL (1 mW) at 1KHz
Frequency Response	10-30,000 Hz
Max. Input Power	200 mW
Rated Impedance	40 Ω (copper-coated aluminum wire)
Headphone Caliper Pressure	5 N
Cable	Detachable 1-meter (3.3 ft.) & 3-meter (9.8 ft.) straight, single-sided; plugin cable on headphones (mini stereo connector)
Connectors	Gold plated stereo mini plug
Net Weight (without cable)	250 g (8.8 oz)
Accessories Furnished	FD1YW 1M straight cable, FD3YW 3M straight cable, 3.5 mm/6.3 mm Plug adapter, Cable Clip, Carrying Pouch



## HD688

### Closed-back Type Headphone

Heavy Bass Music / POP Music / Rock Music

Equipped with the tailored ultra-high precision triple-layer diaphragm in order to reproduce the nature sound with less sound coloration and more balanced sound field. You are able to catch the clear resolution of each part and open sound field especially for the elasticity and the lasting charm of the bass instrument which is perfect for pop and rock.

- Closed-back, Circumaural
- Excellent sound quality
- Tailored ultra-high precision double-layer diaphragm design
- Low distortion, keeping high sound quality
- Detachable single side design
- 40 Ω impedance to provide best use with portable device which can also be used with the high-definition headphone amplifier system



- a** Self-adjusting headband
- b** Detachable
- c** Cable clip
- d** Ear pads

Ear Pad Kit EPK687 is for HD687 and HD688 headphone. Each kit includes a pair of earpad and a pair of foam disks.

#### Specifications

Type	Dynamic, Closed-back
Driver	Ø51 mm, neodymium
Sensitivity	94 dB SPL (1 mW) at 1KHz
Frequency Response	10-30,000 Hz
Max. Input Power	200 mW
Rated Impedance	40 Ω (copper-coated aluminum wire)
Headphone Caliper Pressure	5 N
Cable	Detachable 1-meter (3.3 ft.) & 3-meter (9.8 ft.) straight, single-sided; plugin cable on headphones (mini stereo connector)
Connectors	Gold plated stereo mini plug
Net Weight (without cable)	250 g (8.8 oz)
Accessories Furnished	FD1YW 1M straight cable, FD3YW 3M straight cable, 3.5 mm/6.3 mm Plug adapter, Cable Clip, Carrying Pouch



## HD671

### Silicone Material Closed-back Headphone

Long Term Wearing / Cybercafe / Library / Multiple Users

This over-ear headphone with self-adjusting headband is equipped with a Ø50mm dynamic driver and closed-back structure.

HD671 is simple and fashionable in design and super lightweight with a great fit. The HD671 features a low impedance and extraordinary sound quality even when connecting directly to smart phones.

HD671 is the most light contact pressure closed-back headphone in the world. Equipped with soft silicone earpads, HD671 delivers optimal fit and comfort as well as superior isolation.

- Dynamic closed-back headphone
- Ø50mm precise composite diaphragm
- Lightweight design
- Studio monitoring grade, precise and balance sound
- Robust structure design

The advantage of the silicone earpads:

- The high flexibility and softness of the silicone earpads provides best-fit for the ears
- The silicone earpads significantly reduce sound leakage for the best listening experience with more powerful bass
- High durability compared to the normal earpads
- Extraordinary noise reduction for excellent ambient noise isolation
- Washable pads for easy cleaning
- The soft pads enable long term wearing
- Non-toxic design

#### Specifications

Type	Dynamic, Closed-back
Driver	Ø50 mm, neodymium
Frequency Response	20-20,000 Hz
Impedence	32 Ω
Sensitivity	95 dB (1 mW)
Connector	Gold plated 3.5 mm stereo mini plug
Cable length	Ø3.5 × 2.5 m
Headphone Caliper Pressure	3.5 N
Finish	Black / White
Accessories Furnished	Soft carrying pouch, Screw-on gold-coated 3.5mm to 6.3mm stereo adapter



## HD672

### Silicone Material Semi-Open Headphone

Long Term Wearing / Cybercafe / Library / Multiple Users

HD672 is equipped with the Ø50mm specialized precise composite diaphragm. Its balanced frequency response, high sensitivity and low impedance provides perfect sound quality as well as clarity and details.

HD672 can be used with audio devices with a low power output. Equipped with soft silicone earpads, lightweight and durable structure, the HD672 is able to deliver ultimate comfort during long-time usage. HD672 is the ideal partner for music appreciation and music reproduction. HD672 makes enjoying high quality music reproduction effortless.

- Dynamic semi-open headphone
- Ø50mm precise composite diaphragm
- Lightweight design
- Studio monitoring grade, precise and balance sound
- Robust structure design

The advantage of the silicone earpads:

- The high flexibility and softness of the silicone earpads provides best-fit for the ears
- High durability compared to the normal earpads
- Washable pads for easy cleaning
- The soft pads enable long term wearing
- Non-toxic design

#### Specifications

Type	Dynamic, Semi-open
Driver	Ø50 mm, neodymium
Frequency Response	20-20,000 Hz
Impedence	32 Ω
Sensitivity	95 dB (1 mW)
Connector	Gold plated 3.5 mm stereo mini plug
Cable length	Ø3.5 × 2.5 m
Headphone Caliper Pressure	3.5 N
Finish	Black / White
Accessories Furnished	Soft carrying pouch, Screw-on gold-coated 3.5mm to 6.3mm stereo adapter



## HD662EVO

### Professional Monitoring Closed-back Headphone

#### Recording Studio / Stage

The best-selling model HD662 is a high quality headphone with rich bass, crystal clear high resolution and accurate sound field positioning. Now the new HD662EVO upgraded version has a completely new, more slender shape and an improved smoother, more neutral, treble tone. The HD662EVO easily meets the requirements of stage and studio professionals for a high-quality sound in monitoring headphones.

- Ø50 mm large-diaphragm speaker unit to reproduce accurate sound and large dynamic
- Aural design provides natural sound, able to maintain a comfortable feel during prolonged use
- Self-adjusting headband provides the best fit
- Circumaural, Closed-back
- Next evolution of new HD662EVO with new styling and more slender design

#### Specifications

Type	Dynamic, Closed-back
Driver	Ø50 mm, Neodymium
Sensitivity	98 dB SPL (1 mW) at 1 KHz
Frequency Response	10-30,000 Hz
Max. Input Power	200 mW
Rated Impedance	32 Ω (Copper-coated aluminium wire)
Earpads	Leatherette
Headphone Caliper Pressure	7.5 N
Cables	Detachable 1-meter (3.3 ft.) & 3-meter (9.8 ft.) straight, single-sided; plug-in cable on headphones (mini stereo connector)
Connector	Gold plated stereo mini plug plus 3.5 mm-to-¼" jack adapter
Finish	Black / White
Weight (w/o cable)	250 g (8.8 oz)
Accessories Furnished	1M straight cable, 3M straight cable, ¼" (6.3mm) adapter, Cable Clip, Carrying Pouch



## HD681EVO

### Professional Monitoring Semi-open Headphone

#### Recording Studio

The best-selling model HD681 is a high quality headphone with rich bass, crystal clear high resolution and accurate sound field positioning. Now the new HD681EVO upgraded version has a completely new, more slender shape and an improved smoother, more neutral, treble tone. The HD681EVO easily meets the requirements of stage and studio professionals for a high-quality sound in monitoring headphones.

- New styling and more slender design, plus an improved smoother, more neutral, treble tone
- Ø50 mm large-diaphragm speaker unit to reproduce accurate sound and large dynamic
- Semi-open acoustic design
- Aural design provides natural sound, able to maintain a comfortable feel during prolonged use
- Self-adjusting headband provides the best fit
- Detachable, single side cable

#### Specifications

Type	Dynamic, Semi-open
Driver	Ø50 mm, Neodymium
Sensitivity	98 dB SPL (1 mW) at 1 KHz
Frequency Response	10-30,000 Hz
Max. Input Power	300 mW
Rated Impedance	32 Ω (Copper-coated aluminium wire)
Earpads	Leatherette
Headphone Caliper Pressure	3.5 N
Cables	Detachable 1-meter (3.3 ft.) & 3-meter (9.8 ft.) straight, single-sided; plug-in cable on headphones (mini stereo connector)
Connector	Gold plated stereo mini plug
Finish	Black / White
Weight (w/o cable)	265 g (9.3 oz)
Accessories Furnished	1M straight cable, 3M straight cable, ¼" (6.3mm) adapter, Cable Clip, Carrying Pouch



## HD681AIR

### Professional Monitoring Headphones Air-Cushion Earpads Edition

#### Recording Studio / Long Term Wearing

When Superlux's best-selling headphones, the HD681, meet specially designed air-cushion earpads, it creates a stunningly expansive auditory feast!

Thanks to the soft, thin air-cushion material, the HD681 becomes lighter and more snug to wear. Compared to traditional leather ear pads, the air-cushioned ear pads can self-adjust to the irregular shape of the human head, significantly improving the long-standing issue of bass leakage for headphone manufacturers. Simultaneously, the lightweight and elastic ear pad material provides subtle vibrations on the skin's surface, offering an additional vibration akin to an extra subwoofer, making music appreciation even more immersive!

The HD681-AIR edition package includes both traditional leather earpads and extra air-cushion earpads, inviting all music enthusiasts to embrace and explore different listening experiences!

- Enjoy a wider soundstage with specially designed air-cushion earpads on the best-selling HD681 headphones
- Soft, thin earpads material ensures a snug fit and lightweight feel for extended wear
- Includes both air-cushion and traditional leather earpads for customizable listening

The advantage of the silicone earpads:

- The high flexibility and softness of the silicone earpads provides best-fit for the ears
- High durability compared to the normal earpads
- Washable pads for easy cleaning
- The soft pads enable long term wearing
- Non-toxic design

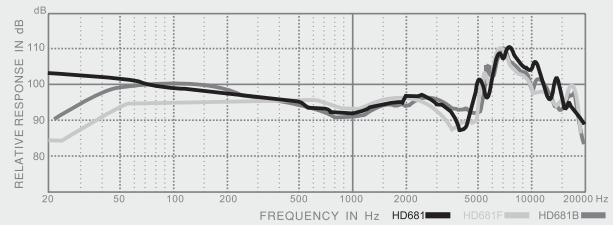
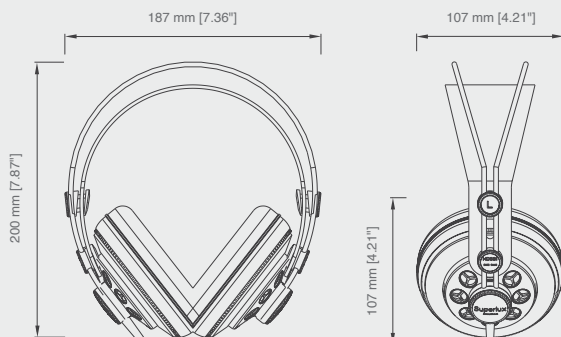

\*FR charts shown above are test results determined by China Standard IEC318 ear simulation.



Deep low frequency "On stage" sound, perfect for enjoying the beauty of classical music & other large ensembles. Both the HD681 & P-brand HP890 have a similar curve, presenting a bright and clear sound. When playing classical music, the HD681 will surprise you with its breadth, clarity and dynamic presence.

#### Specifications

Types	Circumaural, Semi-open
Driver	Ø50 mm, Neodymium
Sensitivity	98 dB SPL (1 mW)
Frequency Response	10-30,000 Hz
Max. Input Power	300 mW
Rated Impedance	32 Ω (Copper-coated aluminium wire)
Earpads	Latherette, Air-Cushion earpads
Cables	2.5 meter (8.2 ft.) straight
Connector	Gold-plated stereo mini plug plus 3.5-to-6.3 adapter
Weight (w/o cable)	320 g (11.28 oz)
Accessories Furnished	3.5 mm to 6.3 mm Plug Adapter, Air-cushion Earpads, Carrying Pouch



# HD669

## Professional Studio Standard Monitoring Headphones

### Recording Studio

The HD669 are closed-back, circumaural headphones designed for professional monitoring applications. Although suitable for a very wide range of applications, the exceptional attenuation of external noise makes the HD669 particularly useful for use in a high-noise environment.

The balanced, high definition and clarity sound of the HD669 assures that a professional sound engineer can have full confidence when recording or monitoring.

- High resolution drivers
- Precision tuned acoustic chamber
- Patented durable structure
- Comfortable, self-adjusting headband pads
- Detachable, single side cable

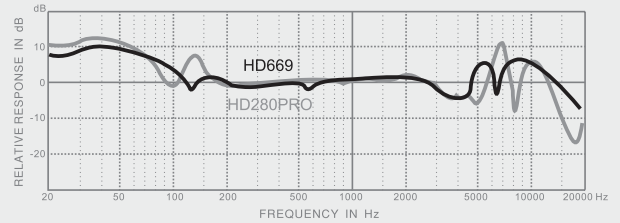

\*FR charts shown above are test results determined by China Standard IEC318 ear simulation.

Both the HD669 and HD280 PRO have a similar frequency curve. HD669 delivers natural and excellent balanced sound, presenting the crystal clarity and high resolution demanded by professional users.

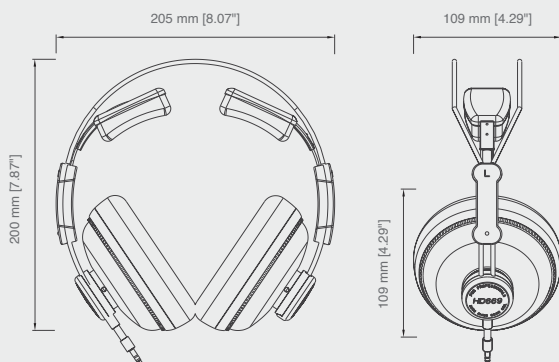

### Specifications

Type	Dynamic, Closed-back
Driver	Ø50 mm, Neodymium
Sensitivity	98 dB SPL (1 mW) at 1 KHz
Frequency Response	10-30,000 Hz
Max. Input Power	200 mW
Rated Impedance	56 Ω (Copper-coated aluminium wire)
Earpads	Leatherette
Cables	Detachable 1-meter (3.3 ft.) & 3-meter (9.8 ft.) straight, single-sided; plug-in cable on headphones (mini stereo connector)
Connector	Gold plated stereo mini plug
Finish	Black
Weight (w/o cable)	235 g (8.2 oz)
Accessories Furnished	1M straight cable, 3M straight cable, 1/4" (6.3mm) adapter, Cable Clip, Carrying Pouch



# HD668B

## Professional Studio Standard Monitoring Headphones

### Recording Studio

The HD668B is a semi-open dynamic headphone whose sound quality meets the demands of even professional recording studios. The balanced and high definition sound of the HD668B assures that a professional sound engineer can have full confidence when mixing down or during post production.

Its patented sturdy headband structure provides longlasting durability even in challenging conditions, yet its light weight and optimized mechanical pressure provides long-term wearing comfort.

- High resolution drivers
- Precision tuned acoustic chamber
- Patented durable structure
- Comfortable, self-adjusting headband pads
- Detachable, single side cable

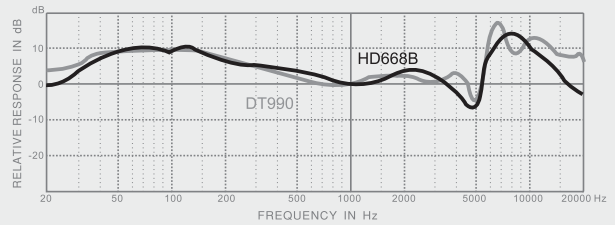

\*FR charts shown above are test results determined by China Standard IEC318 ear simulation.

Both the HD668B and DT990 have a similar frequency curve. The HD668B delivers a natural and excellently balanced sound, presenting the crystal clarity and high resolution demanded by professional users.

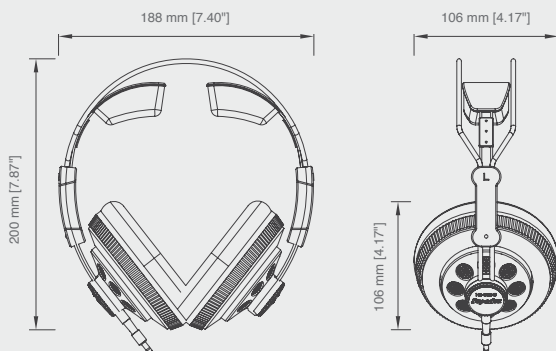

### Specifications

Types	Dynamic, Semi-open
Driver	Ø50 mm, Neodymium
Sensitivity	98 dB SPL (1 mW)
Frequency Response	10-30,000 Hz
Max. Input Power	300 mW
Rated Impedance	56 Ω (Copper-coated aluminium wire)
Earpads	Latherette
Cables	Detachable 1-meter (3.3 ft.) & 3-meter (9.8 ft.) straight, single-sided; plug-in cable on headphones (mini stereo connector)
Connector	Gold-plated stereo mini plug
Finish	Black
Weight (w/o cable)	222 g (7.8 oz)
Accessories Furnished	1M straight cable, 3M straight cable, 1/4" (6.3mm) adapter, Cable Clip, Carrying Pouch



# HD661

## Professional Monitoring Headphone

### Music Appreciation / Recording Studio

The HD661 is a closed-back, circumaural headphone which is excellent for professionals and music lovers because of its sound profile of depth of sound stage. Although suitable for a very wide range of applications, the exceptional attenuation of external noise of the HD661 makes it particularly suitable for use in a high noise environment.

The balanced, high definition and clear sound of the HD661 assures that you can hear every detail of your music.

- Outstanding sound stage reveals all the details
- High noise attenuation
- Ø40 mm high resolution drivers
- Patented self-adjusting headband for great fit and maximum comfort
- Rotating ear pad construction for convenient single-ear monitoring
- Multicolour available

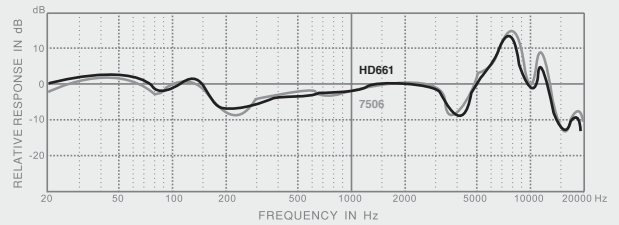

\*FR charts shown above are test results determined by China Standard IEC318 ear simulation.

Both the HD661 and MDR7506 have a similar frequency curve. The HD661 delivers a wide dynamic range and high resolution sound, presenting the crystal clear audio details demanded by professional users.

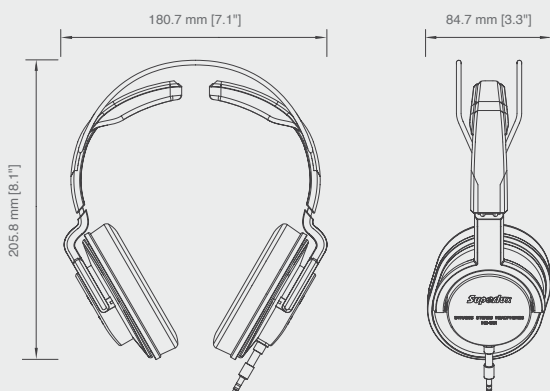

### Specifications

Type	Dynamic, Closed-back
Driver	Ø40 mm, Neodymium
Sensitivity	102 dB SPL (1 mW) at 1 KHz
Frequency Response	10-20,000 Hz
Max. Input Power	200 mW
Rated Impedance	68 Ω (Copper-coated aluminium wire)
Earpads	Leatherette
Cables	1-meter (3.3 ft.) & 3-meter (9.8 ft.) straight cable, single-sided
Connector	Stereo mini jack
Finish	Black / Gray / White / Blue / Green / Purple / Red / Orange / Baby Pink / Hot Pink
Weight (w/o cable)	224 g (7.9 oz)
Accessories Furnished	1M straight cable, 3M straight cable, 1/4" (6.3mm) adapter, Cable Clip, Carrying Pouch

# HD662 Series

## Professional Monitoring Headphones

Recording Studio / Stage monitor

The HD662 series offers three distinctive sound profile, each with its own character. These three headphones also deliver clarity, accurate and well balance sound. The ergonomically designed vinyl ear pieces combined with light weight and self-adjusting headband of these headphones make them very comfortable.

Whether you are monitoring, tracking, mixing or just listening to your MP3 music, you can expect comfort and sonic accuracy from HD662 series headphones.

- High noise attenuation
- Self-adjusting headband for great fit and maximum comfort
- Single sided, straight cable

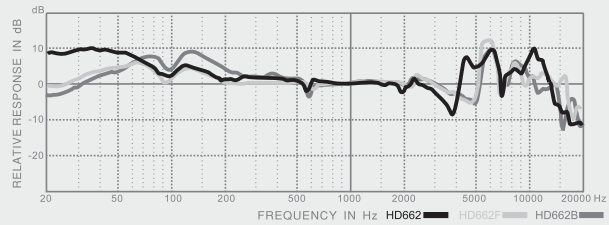

\*FR charts shown above are test results determined by China Standard IEC318 ear simulation.

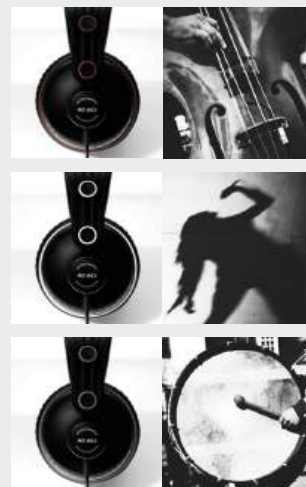

### HD662

Deep and rich bass response "On stage" sound feel. HD662 delivers deep bass, natural and well-balanced sound.

### HD662F

True bass response "Front row" sound feel. HD662F delivers true bass response, crystal clarity and precise sound characters.

### HD662B

Powerful bass punch "In hall" sound feel. HD662B delivers precisely tailored frequency response with powerful bass punch, clear midrange and extended highs.

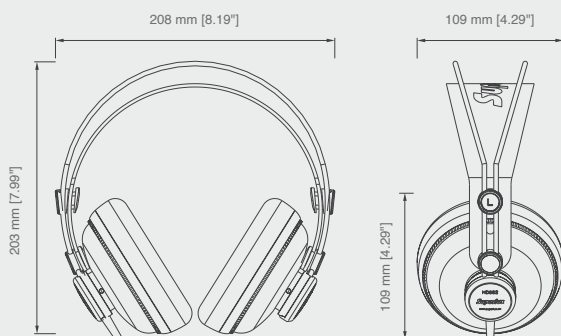

### Specifications

Type	Dynamic, Closed-back
Driver	Ø50 mm, Neodymium
Sensitivity	98 dB SPL (1 mW) at 1 KHz
Frequency Response	10-30,000 Hz
Max. Input Power	HD662: 200 mW HD662F & HD662B: 300 mW
Rated Impedance	32 Ω (Copper-coated aluminium wire)
Earpads	Leatherette
Cables	2.5 meter (8.2 ft.) straight
Connector	Gold-plated stereo mini plug plus 3.5-to-6.3 adapter
Headphone Caliper Pressure	5 N
Weight (w/o cable)	286 g (10.08 oz)
Finish	HD662 Red / HD662F White / HD662B Grey
Accessories Furnished	3.5 mm to 6.3 mm Plug Adapter, Carrying Pouch



## HD681 Series

### Professional Monitoring Headphones

#### Recording Studio

The HD681 series headphones offer 3 distinctive sound profiles, each with its own character. These three headphones also deliver excellent balance and clarity. The ergonomically-designed vinyl ear pieces combined with the light weight and self-adjusting headband of these headphones make them very comfortable.

Whether you're monitoring, tracking, mixing, or just listening to an MP3 or other audio source, you can expect comfort and sonic accuracy from your HD681 series headphones.

- Accurate and detailed sound greatly enhances your listening experience
- Self-adjusting headband for great fit and maximum comfort
- Single sided, straight cable

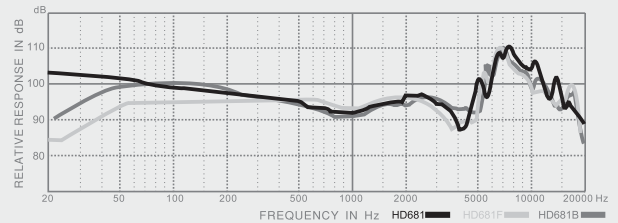

\*FR charts shown above are test results determined by China Standard IEC318 ear simulation.



#### HD681

Deep low frequency "On stage" sound, perfect for enjoying the beauty of classical music & other large ensembles. The HD681 presents a bright and clear sound. When playing classical music, the HD681 will surprise you with its breadth, clarity and dynamic presence.



#### HD681F

Flat extended frequency response "Front row" sound image, great for pop music and capturing that sweet vocal sound. The HD681F delivers a sweet sound just as if the singer was standing right in front of you.



#### HD681B

Balanced character and powerful bass "In hall" feel, great for enjoying rock music and similar exciting performance. The HD681B optimizes a powerful bass and balanced tone, and it will be rhythm from your headphones.

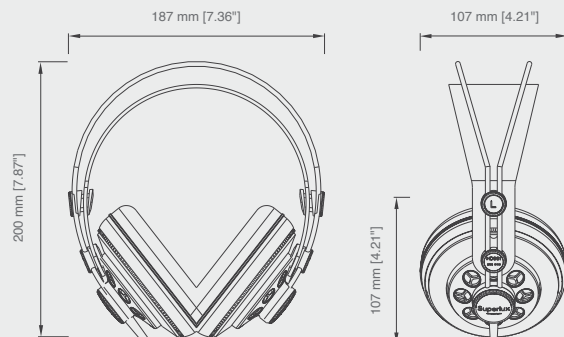

#### Specifications

Types	Dynamic, Semi-open
Driver	Ø50 mm, Neodymium
Sensitivity	98 dB SPL (1 mW)
Frequency Response	10-30,000 Hz
Max. Input Power	300 mW
Rated Impedance	32 Ω (Copper-coated aluminium wire)
Earpads	Latherette
Cables	2.5 meter (8.2 ft.) straight
Connector	Gold-plated stereo mini plug plus 3.5-to-6.3 adapter
Finish	HD681 Red / HD681F White / HD681B Grey
Weight (w/o cable)	230 g (8.11 oz)
Accessories Furnished	3.5 mm to 6.3 mm Plug Adapter, Carrying Pouch



## HD572

### Monitoring Headphones

#### Recording / DJ

The HD572 is a supra-aural close-back headphones, which offer better isolation from ambient noise and feature high sound pressure level capability and exceptional comfortable fit. The HD572 features a powerful bass punch, expressly designed to convey the power of drums, while the enhanced mid and high frequencies give high resolution and detail, working well even in noisy environments.

The folding swing-arms allow for one-sided monitoring and will fold into a small package that takes almost no space in your bag. All these features plus a wide, comfortable, moulded and detented adjustable headband, make these headphones ideal for studio and DJ use. The ruggedly constructed HD572's comfort level is as impressive as its powerful low end and accurate sonic imaging.

- Foldable swing-arms for one-sided monitoring
- Wide, comfortable headband
- Adjustable detent headband
- High SPL capability



Foldable swing-arms for one-sided monitoring

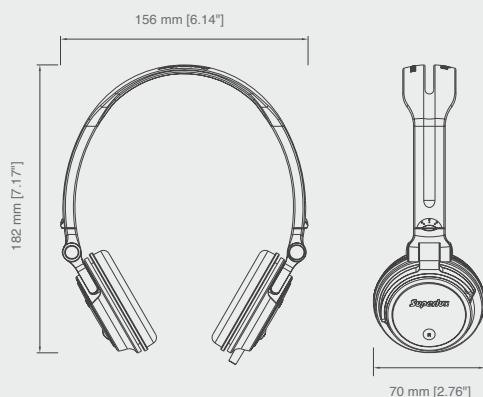

#### Specifications

Type	Dynamic, Closed-back
Driver	Ø30 mm, Neodymium
Sensitivity	99 dB SPL (1 mW) at 1 KHz
Frequency Response	20-20,000 Hz
Max. Input Power	200 mW
Rated Impedance	24 Ω (Copper-coated aluminium wire)
Earpads	Leatherette
Cables	2-meter (6.6 ft.)
Connector	Gold plated stereo mini plug
Headphone Caliper Pressure	3.5 N
Weight (w/o cable)	130 g (4.58 oz)
Finish	Black
Accessories Furnished	3.5 mm to 6.3 mm Plug Adapter, Carrying Pouch



## HD572A

### Lightweight Collapsible Headphone

#### Music Appreciation / Entertainment

The HD572A is a supra-aural open headphone with flat ear pads, offering extremely comfortable wearing. Open headphones sound more “natural” than closed models, but cannot avoid both sound leaking out from the headphones, and sound leaking in. A white body along with 4 color ear pads included makes the HD572A a perfect headphone to suit your own on-the-go style. Featuring high sound pressure level tolerance and a foldable earpads for compact storage, the HD572A is ideally suited for use with portable sound devices such as MP3 players or smartphones. Its solid powerful bass and bright mid- high frequency band makes it perfect for pop and rock music, outperforming regular mini headphones.

- Comfortable supra-aural open design
- Delivers amazing sound
- Solid powerful bass and bright mid-high frequency band
- Foldable style for easy transport
- Lightweight and comfortable for music-on-the-move
- All-purpose headphones for serious listening with home entertainment systems , portable players and multimedia devices
- Multiple colors available

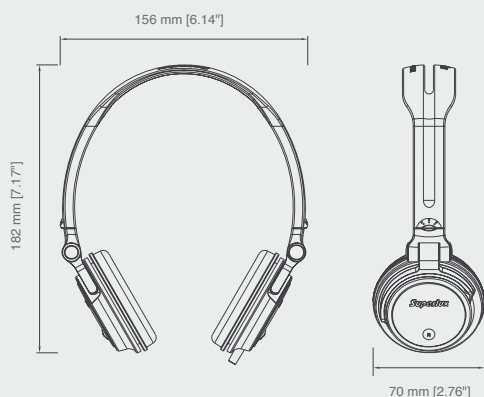

#### Specifications

Type	Dynamic, supra-aural, open
Driver	Ø30 mm, Neodymium
Sensitivity	102 dB SPL (1 mW) at 1 KHz
Frequency Response	20-20,000 Hz
Max. Input Power	200 mW
Rated Impedance	24 Ω (Copper-coated aluminium wire)
THD	< 0.25% @ 1kHz / 1V
Earpads	Sponge
Cables	1.2-meter (3.94 ft.)
Connector	Gold plated stereo mini plug
Headphone Caliper Pressure	3.5 N
Weight (w/o cable)	121 g (4.3 oz)
Accessories Furnished	Colorful Earpads, Carrying Pouch



## HD660

### Professional Monitoring Headphone

#### Recording Studio

The HD660 is a closed-back dynamic headphone for the most demanding professionals. The accurate sound profile and comfortable headband make the HD660 the perfect monitoring headphone for recording studios, post production or broadcasting applications.

With a carefully tailored frequency response, the HD660 offers an excellent clarity of sound with a natural and balanced character. Soft earpads and adjustable, sliding earpieces, together with a single-sided connecting cable, ensure listening comfort during long term use.

- Natural and well-balanced sound profile
- Ultra-detailed high and mid-range reproduction
- Durable headband construction with optimized pressure
- Single sided cable

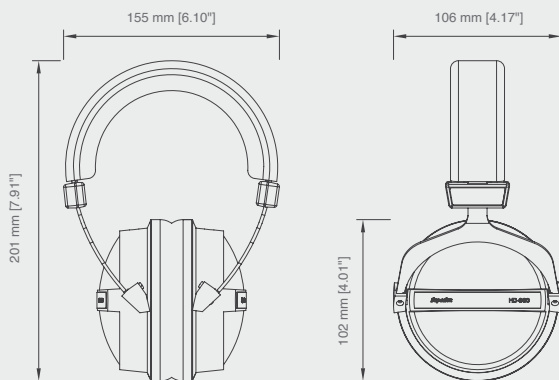

#### Specifications

Type	Dynamic, Closed-back
Driver	Ø40 mm, Neodymium
Sensitivity	96 dB SPL (1 mW) at 1 KHz
Frequency Response	10-30,000 Hz
Max. Input Power	100 mW
Rated Impedance	150 Ω
Earpads	Leatherette
Cables	3-meter (9.8 ft.) coiled, single-sided cable
Connector	Screw-on gold plated stereo mini plug
Headphone Caliper Pressure	6 N
Weight (with cable)	250 g (8.8 oz)
Finish	Black
Accessories Furnished	Threaded 1/4" gold-plated stereo adapter, Carrying case



## HD330

### Audiophile Headphone

#### Monitor / Music Appreciation

The HD330 is a semi-open dynamic audiophile headphone suitable for most kinds of music. The accurate sound profile and comfortable headband make the HD330 the perfect headphone for both the music enthusiast and the professional recording engineer.

With a carefully tailored frequency response and enhanced bass, the HD330 offers a bass punch and excellent clarity of sound with a natural and balanced character. Soft earpads and adjustable, sliding earpieces, together with a single-sided connecting cable, ensure listening comfort during long-term use. A sturdy plastic storage box ensures secure protection during transportation.

- Enhanced bass
- Natural and well-balanced sound profile
- Ultra-detailed high and mid-range reproduction
- Durable headband construction with optimized pressure

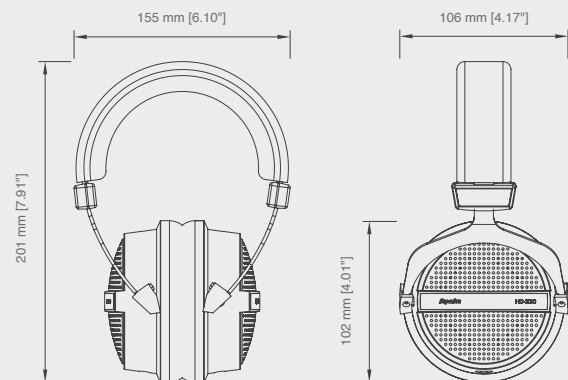

#### Specifications

Type	Dynamic, Semi-open
Driver	Ø40 mm, Neodymium
Sensitivity	96 dB SPL (1 mW) at 1 KHz
Frequency Response	10-30,000 Hz
Max. Input Power	100 mW
Rated Impedance	150 Ω (Copper-coated aluminium wire)
Earpads	Leatherette
Cables	3-meter (9.8 ft.) coiled, single-sided cable
Connector	Gold plated stereo mini plug plus 3.5 to 6.3 mm adapter
Headphone Caliper Pressure	6 N
Weight (with cable)	244 g (8.6 oz)
Finish	Black
Accessories Furnished	1/4" (6.3 mm) adapter, Carrying case



# Drummer Headphone



## HD667

### Professional Drummer Headphones

#### Monitor / Recording Studio

HD667 is a high-quality monitoring headphone designed specifically for drummers. With its simple yet refined appearance, it perfectly embodies the drummer's understated yet rebellious personality. Every detail reflects a professional standard and unique style. Equipped with a 40 mm driver, it captures every sound detail with precision, whether it's deep bass or crisp highs, delivering a clean and clear sound quality. As the second-generation professional drummer headphone from Superlux, the HD667 features an upgraded sponge headband design, offering an even more comfortable wearing experience. Whether used in the studio or on stage for extended periods, it effectively reduces fatigue, providing continuous comfort.

The HD667 also comes with a 2-meter detachable cable, featuring a locking mechanism to ensure a stable connection and prevent accidental disconnections. The cable includes an in-line volume control, allowing you to adjust the volume easily at any time without relying on external devices, enhancing the convenience and freedom of your listening experience. Additionally, the headphones come with a soft velvet pouch, offering protection when not in use, preventing scratches and damage, and ensuring the headphones always remain in like-new condition, providing a more refined user experience.

- **Designed for Drummers:** Captures every drum sound detail with clarity and precision, providing clean and clear audio, ideal for professional monitoring needs
- **40 mm Driver:** Delivers powerful bass and crisp highs, ensuring every detail of the sound is perfectly reproduced
- **Comfortable Sponge Headband:** The upgraded sponge headband design ensures pressure-free comfort, making it suitable for long-term use
- **Stable Detachable Cable:** Equipped with a 2-meter detachable cable and locking mechanism, ensuring a stable connection and preventing accidental disconnections
- **Convenient Volume Control:** The cable features an in-line volume control, allowing you to adjust the volume with ease, offering simple and convenient operation
- **Soft Velvet Storage Pouch:** Includes a soft velvet pouch to protect the headphones from scratches and damage, keeping them in like-new condition and easy to carry and store

#### Specifications

Type	Dynamic, Closed-back
Driver	Ø40 mm, Neodymium
Sensitivity	102 dB SPL (1 mW) at 1 KHz
Frequency Response	10-20,000 Hz
Max. Input Power	200 mW
Rated Impedance	32 Ω @1k Hz
Ear pads	Leatherette
Cables	2-meter straight cable
Connector	Gold plated stereo mini plug plus 3.5-6.3 adapter
Net Weight (Without cable)	335 g (11.81 oz.)
Accessories Furnished	2M Straight cable, Carrying pouch, 3.5 mm to 6.3 mm Plug adapter



## HD665

### Professional Studio Headphone

#### Monitor / Recording Studio

With HD665's well-defined bass reproduction and clear mid-high sound profile, these professional studio monitoring headphones are perfect for drummers and bass players.

They provide great isolation and drastically reduce levels of external sound reaching a musician's ears, offering valuable protection from potential damage. Self-adjusting headband and foam cushions ensure great fit and maximum comfort. HD665 is great for recording and live situations or playing along with recorded music.

- Well-defined bass reproduction and high resolution character
- Large, high-performance 40 mm (1.6") drivers provide high sound pressure level and convincing sound
- Advanced closed-back design ensures high noise reduction
- Auto-adjustable headband and circumaural design for comfort during long work sessions

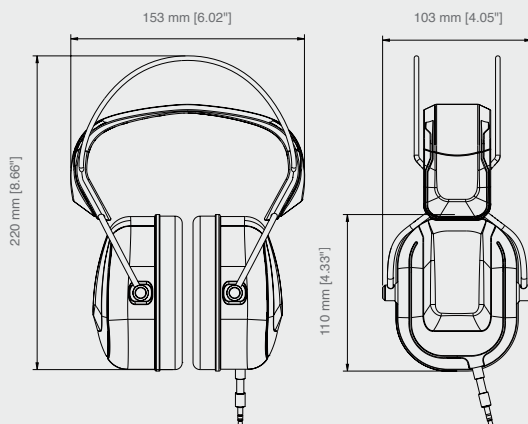

#### Specifications

Type	Dynamic, Closed-back
Driver	Ø40 mm, Neodymium
Sensitivity	102 dB SPL (1 mW) at 1 KHz
Frequency Response	10-20,000 Hz
Max. Input Power	200 mW
Rated Impedance	68 Ω (Copper-coated aluminum wire)
Earpads	Leatherette
Cables	3-meter (9.8 ft.) straight, single-sided, plugin cable on headphones (mini stereo connector)
Connector	Gold plated stereo mini plug plus 3.5-6.3 adapter
Headphone Caliper Pressure	10 N
Weight (with cable)	400 g (14.1 oz)
Accessories Furnished	3M straight cable, 1/4" (6.3 mm) adapter, Cable clip, Carrying pouch



## HD631

### DJ Headphone

#### DJ / Professional Monitor

HD631 is a high sound quality headphone developed specially for professional DJs, designed to clearly emphasize the beat of the music as well as capturing its more subtle nuances. With its 51 mm (2") extra-large diaphragms and highenergy Neodymium magnets, HD631 presents an excellent, balanced sound profile while giving an extra punch to the low end frequencies.

- Powerful bass and clear mid-to-high sound ranges capture subtle nuances of the music
- 51 mm (2") large diaphragm offers high efficiency and wide dynamic range
- Patented auto-adjustable headband construction offers a truly comfortable
- Rotating ear pad construction for convenient single-ear monitoring
- Detachable 3m coiled cable, included cable clip secures the detachable cable from pulling out by accident

#### Specifications

Type	Dynamic, Closed-back
Driver	Ø51 mm, Neodymium
Sensitivity	101 dB SPL (1 mW) at 1 KHz
Frequency Response	20-20,000 Hz
Max. Input Power	3,000 mW
Rated Impedance	40 Ω
Earpads	Leatherette
Headphone Caliper Pressure	5 N
Cables	3-meter (9.8 ft.) coiled, single-sided cable
Connector	Gold plated stereo mini plug plus 3.5-6.3 adapter
Finish	Black / Red
Weight (with cable)	300 g (10.58 oz)
Accessories Furnished	3M coiled cable, 1/4" (6.3 mm) adapter, Cable clip, Carrying pouch



## HD562

### All-Purpose Headphone

Recording / Monitoring / Music / Entertainment / DJ

Featuring a tailored sound profile with extended frequency response and higher sound pressure level, the HD562 is an all-purpose headphone capable of revealing every detail of the sound. Its light-weight and soft cushioning makes the HD562 comfortable even in a long session. Its excellent isolation also makes the HD562 perform well in high noise environments while a rotatable ear cup allows for single-ear monitoring. People will find the HD562 is the right choice in headphones, perfect for music / entertainment, ENG, live or studio use and also ideal for cameramen and DJs.

- Comfortable fit due to its light-weight, split headband and soft ear pads
- Excellent noise isolation achieved by its closed design
- Swiveling ear cup for single-ear monitoring
- Detachable cable

#### Specifications

Type	Supra-aural, Closed-back
Driver	Ø39 mm, Neodymium
Sensitivity	99 dB SPL (1 mW) at 1 KHz
Frequency Response	10-30,000 Hz
Max. Input Power	200 mW
Rated Impedance	70 Ω (Copper-coated aluminium wire)
Earpads	Leatherette
Cables	Detachable 1.2M (3.94 ft.), straight, single-sided, 3M coiled cable
Connector	Gold plated stereo mini plug
Weight (with cable)	180 g (6.3 oz)
Finish	Black / White / Red
Accessories Furnished	1.2M straight cable, 1/4" (6.3 mm) adapter, Cable clip, Carrying pouch



## HD685

### High-Definition Stereo Headphone

Music Appreciation

Designed to reproduce a tight bass while also featuring a sweet and clear mid-high sound profile, the HD685 is a pleasant partner for enjoying your music on the move, whether walking or sitting in a coffee shop. Its foldable structure allows for easy storage, saving your space, and the extra headphone cable includes an in-line control with microphone to allow you to easily pick up an incoming call. The HD685 is the perfect companion to enjoy your favorite music wherever you go.

- Reveals details and powerful bass for today's music
- In-line control headphone cable with microphone, made for smartphones
- Soft ear pads and headband provide comfortable fit
- Foldable design for easy storage

#### Specifications

Type	Dynamic, Closed-back
Driver	Ø40 mm, Neodymium
Sensitivity	102 dB SPL (1 mW) at 1 KHz
Frequency Response	10-20,000 Hz
Max. Input Power	200 mW
Rated Impedance	68 Ω
Earpads	Leatherette
Headphone Caliper Pressure	4.5 N
Cables	1.2-meter (3.94 ft.) cable with in-line control and mic / 1.2-meter (3.94 ft.) standard headphone cable
Connector	1/8 (3.5 mm) low profile angled, plug / 1/8 (3.5 mm) straight plug
Finish	Black
Weight (with cable)	285 g (10.05 oz)
Accessories Furnished	1.2-meter (3') straight cable, 1.2-meter remote & mic cable, Cable clip, Carrying pouch



## HD581

### Supra-Aural Headphone

Recording / Entertainment

HD581 is a unique structural design of the closed headphones, using Ø39 mm drivers for wide and balanced frequency response, great extensity. Premium earpads material for durability and comfort. The head band fits most shapes and sizes. Perfect for professional monitoring and personal entertainment. Simple matte black and elegant white.

- Unique structure design to achieve ultimate comfort even when long-time wearing
- Equipped with tailored Ø39 mm driver for wide and balanced frequency response, great extensity, and high-resolution sound quality
- Premium earpad material for high durability and comfort

#### Specifications

Type	Dynamic, Supra-aural
Driver	Ø39 mm, Neodymium
Sensitivity	103 dB SPL (1 mW) at 1 KHz
Frequency Response	20-20,000 Hz
Max. Input Power	200 mW
Rated Impedance	70 Ω
Earpads	Leatherette
Headphone Caliper Pressure	3.5 N
Cables	1-meter (3.3 ft.) straight, double-sided
Connector	Gold plated stereo mini plug
Finish	Black / White
Weight (w/o cable)	185 g (6.52 oz)
Accessories Furnished	1-meter (3.3') straight cable, Carrying pouch



## HD440

### Booming Bass Headphone

Entertainment / Games

The HD440 features a booming bass and crystal-clear high frequency. It's great for most kinds of music and exceptional for computer gaming. The included self-adjusting headband and optimized headband pressure offer a truly comfortable fit for long-term use. The included sturdy plastic storage box ensures secure protection during transportation.

- Booming bass headphones, great for most kinds of music
- Self-adjusting headband for optimum fit
- High noise attenuation for optimum ambient-noise control

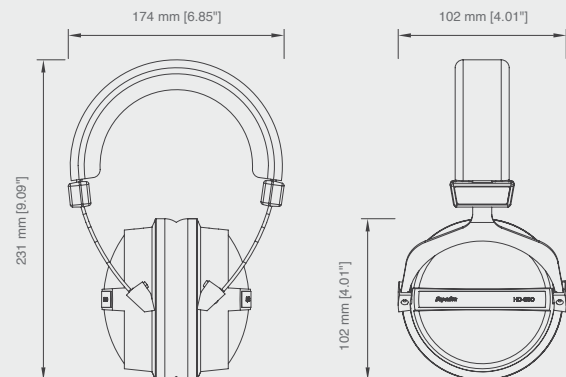

#### Specifications

Type	Dynamic, Closed-back
Driver	Ø40 mm, Neodymium
Sensitivity	96 dB SPL (1 mW) at 1 KHz
Frequency Response	20-20,000 Hz
Max. Input Power	100 mW
Rated Impedance	150 Ω (Copper-coated aluminium wire)
Earpads	Leatherette
Cables	2.5-meter (8.2 ft.) straight, single-sided cable
Connector	Gold plated stereo mini plug
Headphone Caliper Pressure	4 N
Finish	Black
Weight (with cable)	300 g (10.6 oz)
Accessories Furnished	1/4" (6.3 mm) adapter, Carrying pouch

# HD651

## Circumaural Closed-Back Headphone

### Music Appreciation / Entertainment

HD651 presents accurate and rich bass, and excellent vocal sound, perfect for both music lovers and artists. Powerful 40 mm (1.6 in.) speakers provide a superbly natural, uncoloured sound. When you are monitoring or just listening to an MP3, you can expect comfort and sonic accuracy from your HD651 headphones. HD651 comes with multicolour options and allows you to pick up your favourite one.

- Accurate and rich bass, and excellent vocal sound
- 40 mm speaker driver
- High-energy neodymium magnet
- Patented self-adjusting soft rubber headpad construction
- Multicolour available

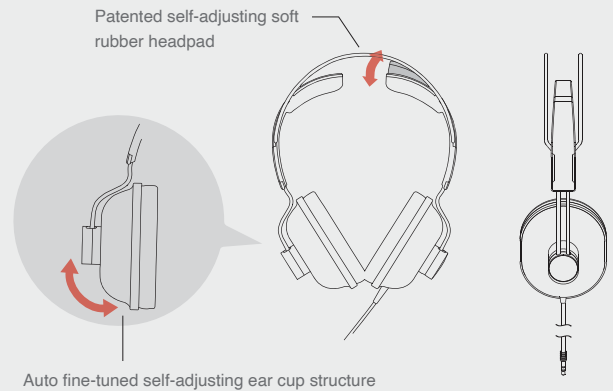

HD651 comes multicolor options

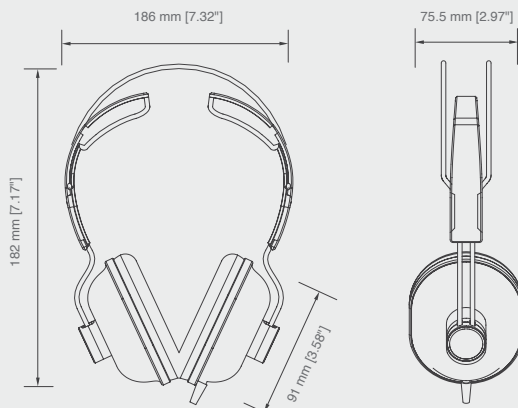

### Specifications

Types	Dynamic, Closed-back
Driver	Ø40 mm, Neodymium
Sensitivity	98 dB SPL (1 mW) at 1 KHz
Frequency Response	20-20,000 Hz
Max. Input Power	200 mW
Rated Impedance	32 Ω (Copper-coated aluminium wire)
Earpads	Leatherette
Cables	2-meter (6.6 ft.) straight cable, single-sided
Connector	Stereo mini jack 3.5 mm & 6.3 mm plug adapter
Headphone Caliper Pressure	4.5 N
Finish	Black / Gray / White / Navy Blue / Green / Purple / Red / Yellow / Baby Pink / Hot Pink
Weight (with cable)	185 g (6.5 oz)
Accessories Furnished	Carrying pouch



## HD387

### In-Ear Headphone

#### Entertainment / Sports

HD387 is equipped with 8 mm drivers which provides wide and flat frequency response and full spectrum details. Delicate treble and powerful bass delivers immersive music experience!

The unique Cubic backcup design of HD387 delivers the same bass reflection effect as the speaker cabinet to provide deep but clean bass frequency. The ergonomic detachable ear hook design with stability and comfort characteristic will fit your ear when exercise.

- Cubic backcup design delivers the bass reflection effect same as the speaker cabinet to provide deep but clean bass frequency for wide range use
- Ø8 mm driver provides wide and flat frequency response and studio-level sound quality
- Equipped with three different sizes of earplugs and earhooks for every individual to find the best fit
- Ergonomic design improves the stability on ear and prevents fall off easily

#### Specifications

Types	Dynamic, In-ear
Driver	Ø8 mm, Neodymium
Sensitivity	106 dB SPL (1 mW) at 1 KHz
Frequency Response	20-20,000 Hz
Rated Impedance	16 Ω (Copper-coated aluminium wire)
Cables	1.2 meter (3.9 ft.)
Connector	Gold-plated stereo mini jack
Finish	Black / White / Rose Gold
Weight (with cable)	18 g (0.63 oz)
Accessories Furnished	Ear plugs S, M, L, Ear hooks S, M, L, Carrying pouch



## HD387i

### In-Ear Headphone With Remote And Mic

#### Entertainment / Sports

HD387i includes an in-line remote control with microphone for your smartphone or iDevice. It is able to:

- Adjust the volume by pressing the “+” and “-” buttons
- Control music and video playback — including play / pause and next / previous — by pressing the centre button
- Record voice memos on supported devices
- Answer and end calls

- Cubic backcup design delivers the bass reflection effect same as the speaker cabinet to provide deep but clean bass frequency for wide range use
- Ø8 mm driver provides wide and flat frequency response and studio-level sound quality
- Equipped with three different sizes of earplugs and earhooks for every individual to find the best fit
- Ergonomic design improves the stability on ear and prevents fall off easily

#### Specifications

Types	Dynamic, In-ear
Driver	Ø8 mm, Neodymium
Sensitivity	106 dB SPL (1 mW) at 1 KHz
Frequency Response	20-20,000 Hz
Rated Impedance	16 Ω (Copper-coated aluminium wire)
Cables	1.2 meter (3.9 ft.)
Connector	Gold-plated stereo mini jack
Finish	White
Weight (with cable)	18 g (0.63 oz)
Accessories Furnished	Ear plugs S, M, L, Ear hooks S, M, L, Carrying pouch

## Accessories



### HD361

#### In-ear Monitor Headphone

Entertainment / Long Term Wearing

HD361 is a professional monitoring in ear headphone with ultra-high SPL, low distortion, and excellent transient response, which delivers clean and clear sound without any coloration as if you were there ! Ergonomic in ear design to achieve ultimate comfort even when enjoying the pure sound quality after long-time wearing.

- Special resonance box cavity
- Concealing flat curvature design for on site monitoring
- High efficiency and wide dynamic performance
- Low distortion and excellent transient response
- Pure sound reproduction as if you were there!
- Ergonomic design to achieve stable and comfortable wearing



### Y-SPLIT

#### Music Sharing Plug

Black, red and white, three colors.

### Specifications

Types	Dynamic, In-ear
Driver	Ø8 mm, Neodymium
Frequency Response	20-20,000 Hz
Rated Impedance	16 Ω (Copper-coated aluminium wire)
Sensitivity	102 dB SPL (1 mW) at 1 KHz
Cables	0.6-meter (2 ft.) + 0.6-meter (2 ft.)
Connector	Ø3.5 mm (Gold plated stereo mini plug)
Weight (with cable)	18 g (0.63 oz)
Accessories Furnished	Ear plugs S, M, L, Ear hooks S, M, L, Carrying pouch



## HD351

### Lightweight In-Ear Headphone

#### Entertainment

Keeping it simple, the HD351 features classic black or white colour options and delivers outstanding sound quality in a lightweight in-ear headphone.

Equipped with 13.5 mm neodymium drivers, the Superlux HD351 delivers an impressive listening experience. With low distortion and a strong bass line, the HD351 brings an authentic and detailed sound experience.

Equipped with three different sizes of earplugs, the HD351 enables you to find the best fit to eliminate background noise in noisy environments so that all you have to do is pay attention to and enjoy the music.

- Equipped with high efficiency 13.5 mm neodymium drivers to bring clear sound quality
- Classic and simple design. Suitable for portable use
- Comfortable and personalized fit
- Natural, clean, and rich sound quality
- Delivered with three different sizes of earplugs

#### Specifications

Types	Dynamic, In-ear
Driver	Ø13.5 mm, Neodymium
Sensitivity	106 dB SPL (1 mW) at 1 KHz
Frequency Response	20-20,000 Hz
Max. Input Power	50 mW
Rated Impedance	16 Ω (Copper-coated aluminium wire)
Cables	1.2 meter (3.9 ft.)
Connector	Ø3.5 mm (Gold plated stereo mini plug)
Weight (with cable)	
Accessories Furnished	Ear plugs S, M, L



## HD386

### In-Ear Headphone

#### Music Appreciation / Entertainment / Smart phones and tablet PC

The HD386 headphone features a crystal-clear and balanced sound profile that presents the detailed character and richness of each instrument. Great for most kinds of music, the HD386 is ideal for capturing those sweet vocal sounds. As for the sound image presented by the HD386, it gives you the feeling of actually being there, as if you were sitting on the front row in a concert hall.

THE HD386 has a comfortable, personalized fit with superior noise isolation to ensure your complete enjoyment of the music. Six color options are available to allow you to pick up one in your favorite color and a sturdy carrying case is included for safely storing your HD386.

- Dynamic, in-ear headphones
- Comfortable and personalized fit
- Natural, crystal-clear sound
- Convenient carrying case
- Three sizes of ear adapters for a truly comfortable fit



#### Specifications

Types	Dynamic, In-ear
Driver	Ø13.5 mm, Neodymium
Sensitivity	103 dB SPL (1 mW) at 1 KHz
Frequency Response	20-20,000 Hz
Max. Input Power	50 mW
Rated Impedance	16 Ω (Copper-coated aluminium wire)
Cables	1.2 meter (3.9 ft.) straight cable
Connector	Gold plated stereo mini plug
Finish	Baby Pink / Hot Pink / Green / Black / White / Red
Weight (with cable)	16 g (0.56 oz)
Accessories Furnished	Ear adapter, black, large, 1 pair, Ear adapter, grey, medium, 1 pair, Ear adapter, white, small, 1 pair, already put on headphones, Convenient carrying box

# HD381 Series

## In-ear Monitoring Headphone

### Music Appreciation / Entertainment / Monitoring

The HD381 series headphones feature a comfortable, personalized fit with superior noise isolation and offer 3 distinctive sound profiles, each with its own character.

The patented multi-functional cable wrapper / clip wraps the headphone cable neatly or can be clipped on clothes or necktie for added convenience. The HD381 series' high quality reproduction of the natural sound is ideally suited for personal entertainment.

- Comfortable and personalized fit
- Natural, balanced sound
- High efficiency and wide dynamic range
- Patented dual function cable wrapper / clip included



Patented multi-function cable wrapped clip

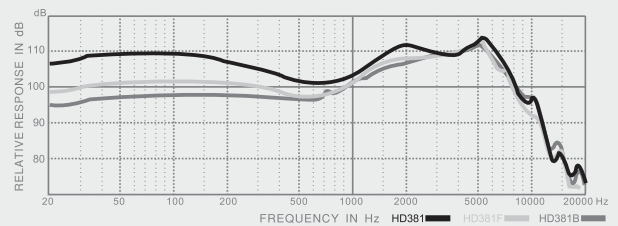

\*FR charts shown above are test results determined by China Standard IEC318 ear simulation.



#### HD381

Rich bass and powerful low end, "On stage" sound, perfect for enjoying that booming bass sound. HD381 presents a pronounced bass presence and will surprise you with its powerful low end performance.



#### HD381F

Flat frequency response, "Front row" sound image, great for most kinds of music and capturing those sweet vocal sounds. The HD381F features a flat response, suitable for most kinds of music, and delivers a sweet vocal sound, as if the singer was standing right in front of you.



#### HD381B

Crystal clear sound, deep and tight bass, "In hall" feel. HD381B the best choice for personal entertainment as well as professional in-ear monitoring applications.

### Specifications

Types	Dynamic, In-ear
Driver	Ø13.5 mm, Neodymium
Sensitivity	103 dB SPL (1 mW) at 1 KHz
Frequency Response	20-20,000 Hz
Max. Input Power	50 mW
Rated Impedance	16 Ω (Copper-coated aluminium wire)
Cables	0.6-meter (1.9 ft.)
Connector	Gold plated stereo mini plug
Weight (with cable)	12 g (0.42 oz)
Finish	HD381 Black / HD381F White / HD381B Grey
Accessories Furnished	Cable wrapper, Ear adapters S, M, L, 0.6 m extension cable



## HMC660PRO

### Professional Headset With Incorporated Condenser Mic

#### Recording Studio / Broadcast

HMC660PRO series are closed-back condenser headsets designed for live broadcasts, DJ's, video conferences, gaming, and multimedia applications. With its tailored frequency response and extremely detailed studio-grade quality driver, HMC660PRO truly delivers the voice of instruments and vocals and the penetration in live environment. HMC660PRO provides precise accuracy and well-balanced sound profile, flatter and wider frequency response and lower distortion.

Equipped with professional condenser capsule with special-designed low proximity effect feature, HMC660PRO avoids the unwanted "pop" sound when use. Moreover, the incorporated condenser mic provides a tailored vocal frequency response that increases intelligibility and offers high gain before feedback. The improved headband design and softer velvet earpads of HMC660PRO ensure listening comfort and fit during long term use. HMC660PRO is available in 32Ω and 150Ω versions to satisfy different environment needs.

- Closed-back headset with condenser microphone
- Professional headset derived from the HD660PRO studio headphone
- Closed-back headphones for optimum ambient noise attenuation
- Integrated professional condenser microphone with supercardioid polar pattern to give excellent speech intelligibility
- Soft velvet earpads ensure listening comfort and fit after long time use

HMC660PRO	MIC, HP: 3.5 mm (1/8") TRRS
HMC660PROE	MIC: 3.5 mm (1/8") stereo mic plug wired as mono; HP: screw-on 3.5 mm (1/8") stereo headphone plug with a 3.5 mm (1/8") to 6.3 mm (1/4") adapter
HMC660PROX	MIC: XLR mic plug; HP: screw-on 3.5 mm (1/8") stereo headphone plug with a 3.5 mm (1/8") to 6.3 mm (1/4") adapter

#### Specifications



Headphones	Type	Dynamic, closed-back
Sensitivity		96 dB SPL (1 mW)
Frequency Response		10 – 30,000 Hz
Max. Input Power		100 mW
Rated Impedance		32 Ω & 150 Ω
Clamping Force		approx. 5N
Cables		2-meter straight cable
Microphone	Type	Condenser Microphone
Polar Pattern		SuperCardioid
Frequency Response		20-20,000 Hz
Sensitivity		-30 ± 3 dBV/Pa
Impedance		2.2K Ω
S/N Ratio		72 dB
Equivalent Noise Level		22 dB
Max. SPL		135 dB SPL
Dynamic Range		113 dB
Power Requirement		1.5-5V / 500uA
Finish		Black
Connector		3.5 mm TRRS
Accessories Furnished		S11 Headworn mic foam, Carrying pouch



## HMD660PRO

### Professional Headset With Incorporated Dynamic Mic

#### Recording Studio / Broadcast

HMD660PRO series are closed-back dynamic headsets designed for live broadcasts, DJ's, video conferences, gaming, and multimedia applications. With its tailored frequency response and extremely detailed studio-grade quality driver, HMD660PRO truly delivers the voice of instruments and vocals and the penetration in live environment. HMD660PRO provides precise accuracy and well-balanced sound profile, flatter and wider frequency response and lower distortion.

Equipped with professional super-cardioid dynamic capsule, HMD660PRO effectively eliminates the unwanted ambient noise and provides perfect speech intelligibility. The improved headband design and softer velvet earpads of HMD660PRO ensure listening comfort and fit during long term use. HMD660PRO is available in 32Ω and 150Ω versions to satisfy different environment needs.

- Dynamic closed back headset
- Professional headset derived from the HD660PRO studio headphone
- Closed-back headphones for optimum ambient noise attenuation
- Integrated professional dynamic microphone with supercardioid polar pattern to give excellent speech intelligibility
- Soft velvet earpads ensure listening comfort and fit after long time use

HMD660PRO	MIC, HP: 3.5 mm (1/8") TRRS
HMD660PROE	MIC: 3.5 mm (1/8") stereo mic plug wired as mono; HP: screw-on 3.5 mm (1/8") stereo headphone plug with a 3.5 mm (1/8") to 6.3 mm (1/4") adapter
HMD660PROX	MIC: XLR mic plug; HP: screw-on 3.5 mm (1/8") stereo headphone plug with a 3.5 mm (1/8") to 6.3 mm (1/4") adapter

#### Specifications



Headphones	Type	Dynamic, closed-back, over-ear
Sensitivity		96 dB SPL (1mW)
Frequency Response		10 – 30,000 Hz
Max. Input Power		100 mW
Rated Impedance		32 Ω & 150 Ω
Clamping Force		approx. 5N
Cables		2-meter straight cable
Microphone	Type	Dynamic Microphone
Polar Pattern		SuperCardioid
Frequency Response		60-17,000 Hz
Sensitivity		-59 dBV/pa
Impedance		500 Ω
Equivalent Noise Level		15 dB
Max. SPL		130 dB
Finish		Black
Connector		3.5 mm TRRS
Accessories Furnished		Headworn mic foam, Carrying pouch

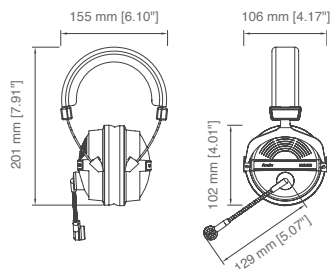

## HMC660

### Professional Headset & Incorporated Condenser Mic

#### Recording Studio / Broadcast

The HMC660 series of stereo headsets are designed for the professionals that demand high quality monitoring plus communication. Their precision acoustic design, integrating drivers, ear padding, and headband, combined with a professional condenser microphone for a balanced tone with high dynamic range make these headsets perfect for both listening and talking. They are ideal for live broadcasts, DJ's, desktop video conferences, on-line gaming and multimedia applications.

- Excellent details, clear midrange and extended highs
- Professional headset derived from the HD660 studio headphone
- Integrated professional condenser microphone PRA30 with supercardioid polar pattern gives high gain before feedback

HMC660	3-meter (9.8') coil spring cord, open end.
HMC660X	3-meter (9.8') coil spring cord, screw-on 3.5 mm (1/8") stereo headphone plug with a 3.5 mm (1/8") to 6.3 mm (1/4") adapter and an XLR mic plug.
HMC660E	3-meter (9.8') coil spring cord, screw-on 3.5 mm (1/8") stereo headphone plug with a 3.5 mm (1/8") to 6.3 mm (1/4") adapter and a 3.5 mm (1/8") stereo mic plug wired as mono.

#### Specifications



Headphones	
Transducer principle	Dynamic, Closed-back
Sensitivity	96 dB SPL (1 mW)
Frequency Response	10-30,000 Hz
Max. Input Power	100 mW
Rated Impedance	150 Ω (Copper-coated aluminium wire)
Caliper Pressure	6 N
Weight (w/o cable)	233 g (8.21 oz)
Microphone	
Transducer principle	Back electret condenser
Polar Pattern	Supercardioid
Frequency response	50-15,000 Hz
Sensitivity	-40 dBV / Pa (10 mV / Pa)
Max. SPL	136 dB SPL (THD ≤ 1% 1 kHz)
Equivalent Output Noise (A-weighted)	24 dB (IEC / DIN 651)
Rated Impedance	200 Ω
Dynamic Range	112 dB
Power Requirements	1.5 to 9V DC phantom power
Current Consumption	3 mA
Finish	Black
Accessories Furnished	S11 Windscreen, Carrying case

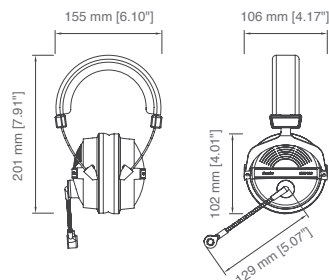
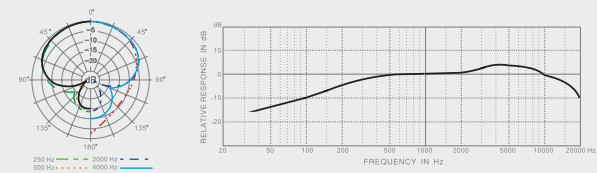

## HMD660

### Professional Headset & Incorporated Dynamic Mic

#### Recording Studio / Broadcast

The HMD660 series of stereo headsets are designed for the professionals that demand high quality monitoring plus communication. Their precision acoustic design, integrating drivers, ear padding, and headband, combined with a professional dynamic microphone for a balanced tone with high dynamic range make these headsets perfect for both listening and talking. They are ideal for live broadcasts, DJ's, desktop video conferences, on-line gaming and multimedia applications.

- Excellent details, clear midrange and extended highs
- Professional headset derived from the HD660 studio headphone
- Integrated professional dynamic microphone PRA20 with cardioid polar pattern gives high gain before feedback

HMD660	3-meter (9.8') coil spring cord, open end.
HMD660X	3-meter (9.8') coil spring cord, screw-on 3.5 mm (1/8") stereo headphone plug with a 3.5 mm (1/8") to 6.3 mm (1/4") adapter and an XLR mic plug.
HMD660E	3-meter (9.8') coil spring cord, screw-on 3.5 mm (1/8") stereo headphone plug with a 3.5 mm (1/8") to 6.3 mm (1/4") adapter and a 3.5 mm (1/8") stereo mic plug wired as mono.

#### Specifications



Headphones	
Transducer principle	Dynamic, Closed-back
Sensitivity	96 dB SPL (1 mW)
Frequency Response	10-30,000 Hz
Max. Input Power	100 mW
Rated Impedance	150 Ω (Copper-coated aluminium wire)
Caliper Pressure	6 N
Weight (w/o cable)	250 g (8.81 oz)
Microphone	
Transducer principle	Dynamic
Polar Pattern	Cardioid
Frequency response	150-10,000 Hz
Sensitivity	-55 ± 2 dB
Max. SPL	136 dB SPL (THD ≤ 1% 1 kHz)
Rated Impedance	250 Ω
Finish	Black
Accessories Furnished	S11 Windscreen, Carrying case

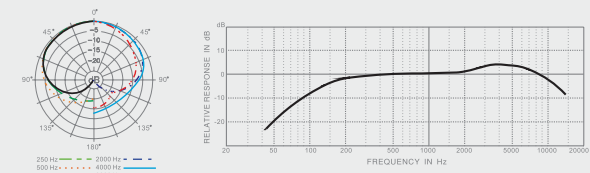



## HMD685

### Double Ear Intercom Headset

Sports Commentators / News Presenters / Podcasting / Conferencing / Intercom / Camera Use

The HMD685 and HMD685a are professional intercom headsets with flexible anti-vibration gooseneck boom microphones. They apply to requirements of demanding broadcast applications for studio or outside productions. The headset is lightweight, provides extra soft ear cushions and headband paddings for outstanding wearing comfort even during extra soft ear cushions Headset is provided with a dynamic vocal unidirectional patterned microphone, featuring excellent acoustic performance and a reliable noise suppression.

- Lightweight with extra soft cushions for comfort fit
- Accurate and linear sound reproduction for professional Radio and TV applications
- Microphone provides audio transmission in broadcast quality
- Reliable performance ensures long lifetime use
- Folding design for easy storage

#### Specifications

Headphones	
Transducer principle	Dynamic, Closed
Ear coupling	Circumaural
Frequency response	20-20,000 Hz
Impedance	Single-ear: 400 Ω Double-ear: 200 Ω
Sensitivity	96 dB SPL at 1 kHz, 1 mW Max.
Input Power	100 mW
Caliper pressure	4.5 N
Connector	1.5-meter (4.92') straight cord, 4-pin XLR female plug
Microphone	
Transducer principle	Dynamic, Cardioid
Frequency response	50-15,000 Hz
Polar Pattern	Cardioid
Sensitivity	-64 dBV/Pa (0.6 mV/Pa) at 1 kHz
Impedance	250 Ω
Finish	Black



## HMD685a

### Single Ear Intercom Headset

Sports Commentators / News Presenters / Podcasting / Conferencing / Intercom / Camera Use

The HMD685 and HMD685a are professional intercom headsets with flexible anti-vibration gooseneck boom microphones. They apply to requirements of demanding broadcast applications for studio or outside productions. The headset is lightweight, provides extra soft ear cushions and headband paddings for outstanding wearing comfort even during extra soft ear cushions Headset is provided with a dynamic vocal unidirectional patterned microphone, featuring excellent acoustic performance and a reliable noise suppression.

- Lightweight with extra soft cushions for comfort fit
- Accurate and linear sound reproduction for professional Radio and TV applications
- Microphone provides audio transmission in broadcast quality
- Reliable performance ensures long lifetime use
- Folding design for easy storage

#### Specifications

Headphones	
Transducer principle	Dynamic, Closed
Ear coupling	Circumaural
Frequency response	20-20,000 Hz
Impedance	Single-ear: 400 Ω Double-ear: 200 Ω
Sensitivity	96 dB SPL at 1 kHz, 1 mW Max.
Input Power	100 mW
Caliper pressure	4.5 N
Connector	1.5-meter (4.92') straight cord, 4-pin XLR female plug
Microphone	
Transducer principle	Dynamic, Cardioid
Frequency response	50-15,000 Hz
Polar Pattern	Cardioid
Sensitivity	-64 dBV/Pa (0.6 mV/Pa) at 1 kHz
Impedance	250 Ω
Finish	Black



## HMD685aMKII

### Single Ear Intercom Headset

Sports Commentators / News Presenters / Podcasting / Conferencing / Intercom / Camera Use

The HMD685MKII and HMD685aMKII are professional intercom headsets with flexible anti-vibration gooseneck boom microphones. They apply to requirements of demanding broadcast applications for studio or outside productions. The headset is lightweight, provides extra soft ear cushions and headband paddings for outstanding wearing comfort even during long production days. Headset is provided with a dynamic vocal unidirectional patterned microphone, featuring excellent acoustic performance and a reliable noise suppression.

- Lightweight with extra soft cushions for comfort fit
- Accurate and linear sound reproduction for professional Radio and TV applications
- Microphone provides audio transmission in broadcast quality
- Reliable performance ensures long lifetime use
- Folding design for easy storage

HMD685aMKII	3-meter (9.8') coil spring cord, open end.
HMD685aMKIIX	3-meter (9.8') coil spring cord, screw-on 3.5 mm (1/8") headphone plug with a 6.3 mm (1/4") adapter and an 3-pin XLR male mic plug.
HMD685aMKIIX4	1.5-meter (4.92') straight cord, 4-pin XLR male plug.
HMD685aMKIIX5	1.5-meter (4.92') straight cord, 5-pin XLR male plug.
HMD685aMKIIE	3-meter (9.8') coil spring cord, screw-on 3.5 mm (1/8") headphone plug with a 6.3 mm (1/4") adapter and a 3.5 mm(1/8") mic plug wired as mono.

### Specifications

Headphones	
Transducer principle	Dynamic, Closed
Ear coupling	Circumaural
Frequency response	20-20,000 Hz
Impedance	400 Ω
Sensitivity	96 dB SPL at 1 kHz, 1 mW
Max. Input Power	100 mW
Caliper pressure	4.5 N
Microphone	
Transducer principle	Condenser, noise compensating, cardioid
Frequency response	50-15,000 Hz
Polar Pattern	Cardioid
Output voltage	-64 dBV/Pa (0.6 mV/Pa) at 1 kHz
Impedance	200 Ω
Finish	Black



## HMC681EVO

### Gaming Headset For PC

Long-Time Wearing / Games

If you are looking for a gaming headset for your long gaming sessions with a comfortable fit and exciting sound experience, the HMC681EVO is the one which professional gamers will love. HMC681EVO will let you experience you are in the game.

- 50 mm speaker units deliver pure sound from games, movies and voice chat
- Unidirectional boom microphone to minimize ambient noise
- Powerful bass and clear mid-to-high sound ranges reproduce every detail in the game
- Circumaural ear pads with a self-adjusting structure ensure perfect fit to the user
- Semi-open acoustic design keeps your head cool and comfortable

### Specifications

Headphones	
Type	Dynamic, Semi-open, Circumaural
Frequency Response	10-30,000 Hz
Impedance	32 Ω (CCAW)
Sensitivity	98 dB SPL
Max. Input Power	300 mW
Microphone	
Frequency Response	80-15,000 Hz
Pick-up pattern	Unidirectional
Impedance	2.2 kΩ
Sensitivity	-45 dBV/Pa (5.6 mV)
General Data	
Cable Length	3-meter (9.8 ft.)
Connectors	2 × 3.5 mm (1/8")
Weight	355 g (12.5 oz.)
Finish	Black



## HMC631

### Professional-Grade PC Gaming Headset

#### Long-Time Wearing / Games

The HMC631 delivers high-quality sound, rugged construction and superior comfort in stylish design. 51 mm premium speakers bring an extra level of realism and excitement to video gaming, giving every detail in the game so you can react quickly to sound cues.

The HMC631 features a boom microphone that offers highly intelligible voice reproduction and filters out most background noise. This headset lets you enjoy the comfort, quality and competitive edge of a professional-grade gaming headset wherever you go.

- Powerful bass and clear mid-to-high sound ranges reproduce every detail in the game.
- 51 mm (2") large diaphragm offers high efficiency and wide dynamic range.
- Patented auto-adjustable headband construction offers a truly comfortable fit.
- Unidirectional boom microphone.
- Passive noise reduction.
- In-live volume control and microphone ON/OFF switch.

#### Specifications

Headphones	
Transducer principle	Circumaural, Closed-back
Sensitivity	102 dB SPL (1 mW)
Frequency Response	20-20,000 Hz
Max. Input Power	1,000 mW
Rated Impedance	40 Ω (Copper-coated aluminium wire)
Cable Length	3-meter (9.8 ft.)
Connectors	2 × 3.5 mm (1/8") stereo jack
Finish	Gray / White / Red
Weight (w/o cable)	350 g (12.3 oz)
Microphone	
Transducer principle	Condenser
Polar Pattern	Cardioid
Frequency response	80-15,000 Hz
Sensitivity	-40 dBV / Pa (10 mV)
Rated Impedance	2.2 kΩ
Finish	Black

**A/HD381  
B/HD681  
C/HD662**  
**Headphone Demo Station**



A/HD381



B/HD681



C/HD662

**Demo Station / Multi-Functional Display**

Superlux is now offering you a unique platform for headphone demonstrations and displays. It is a sales kit which allows customers to test and compare various models of headphones. One kit can accommodate up to three headphones simultaneously. Powered by two AA batteries or AC power, it is easy to use and easy to move anywhere you want to exhibit your products.

- A sales kit for testing and comparison
- Battery powered or AC powered
- Port for iPod Nano for music demos
- HA3D headphones amp included (Mic pre-amp is an option)
- Built-in external audio source input jack
- Built-in extra headphone output jack , making it easy to bring your own headphones for comparison
- Can be hung on a wall with thief- and pulling-proof or placed on a table and even fixed in place with screws if desired

A/HD381 Battery powered / AC powered, HD381, HD381B & HD381F included.

B/HD681 Battery powered / AC powered, HD681, HD681B & HD681F included.

C/HD662 Battery powered / AC powered, HD662, HD662B & HD662F included.



# **Portable PA Systems & Speakers**

# SP Series

## SP108

### Portable PA System

Travel Musician / Busker / Guitarists / Public / Speakers / Vocalists / Performers

The SP Series compact design allows for ease of transportation, while its user-friendly controls offer ease of operation, making it the perfect choice for schools, churches, civic organizations and small musical groups. The SP Series features dual two-way speakers driven by a powered mixer with a class-D power amp, making it ideal for both vocal and musical applications. The convenient accessory compartment storage for cables and additional microphones. This clever design allows the powered mixer to be installed in the speaker compartment or detached for easy positioning and access. The SP Series is a high-performance live-sound system that will deliver your music or message where you go, indoor or out.

- 300W, 8-ch powered mixer
- 8" 2-way speaker
- Less weight, and easy to carry, transport and setup
- Powered mixer with class D power amp, 2-band channel EQ, reverb, and mic stand mountable
- Built-in limiter to prevent overload and damage to amp and speakers
- XLR3F, 1/4" (6.3 mm) and RCA jacks for versatile inputs
- Powered mixer can be used either while installed in the speaker compartment or detached for easy positioning and access
- Storage compartment in the speaker cabinet for packing the included cables, and your microphones
- Speakers can be used as mains or floor monitor

System Includes:

- 2 speakers: SP108 with 8" 2-way; SP110 with 10" 2-way
- 1 Powered Mixer
- 2 speaker cables, 4.5-meter
- 1 power cord

## SP110

### Portable PA System

Travel Musician / Busker / Guitarists / Public / Speakers / Vocalists / Performers

The SP Series compact design allows for ease of transportation, while its user-friendly controls offer ease of operation, making it the perfect choice for schools, churches, civic organizations and small musical groups. The SP Series features dual two-way speakers driven by a powered mixer with a class-D power amp, making it ideal for both vocal and musical applications. The convenient accessory compartment storage for cables and additional microphones. This clever design allows the powered mixer to be installed in the speaker compartment or detached for easy positioning and access. The SP Series is a high-performance live-sound system that will deliver your music or message where you go, indoor or out.

- 500W, 10-ch powered mixer
- 10" 2-way speaker
- Phantom power for condenser microphones
- Compressor and limiter circuitry on channel 1 and 2 for flexible dynamic control
- 35 mm speaker stand socket included
- Less weight, and easy to carry, transport and setup
- Powered mixer with class D power amp, 2-band channel EQ, reverb, and mic stand mountable
- Built-in limiter to prevent overload and damage to amp and speakers
- XLR3F, 1/4" (6.3 mm) and RCA jacks for versatile inputs
- Powered mixer can be used either while installed in the speaker compartment or detached for easy positioning and access
- Storage compartment in the speaker cabinet for packing the included cables, and your microphones
- Speakers can be used as mains or floor monitor

System Includes:

- 2 speakers: SP108 with 8" 2-way; SP110 with 10" 2-way
- 1 Powered Mixer
- 2 speaker cables, 4.5-meter
- 1 power cord



SP108

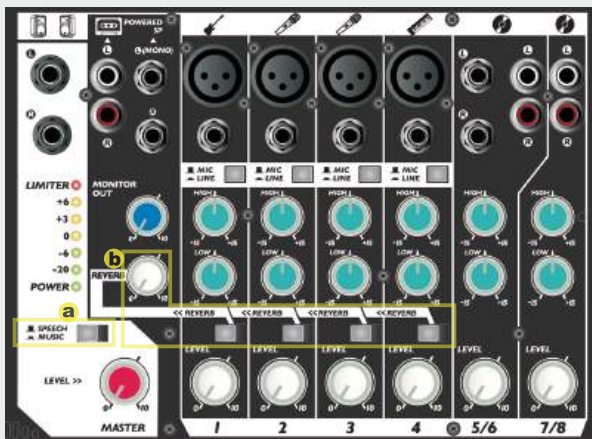

SP110

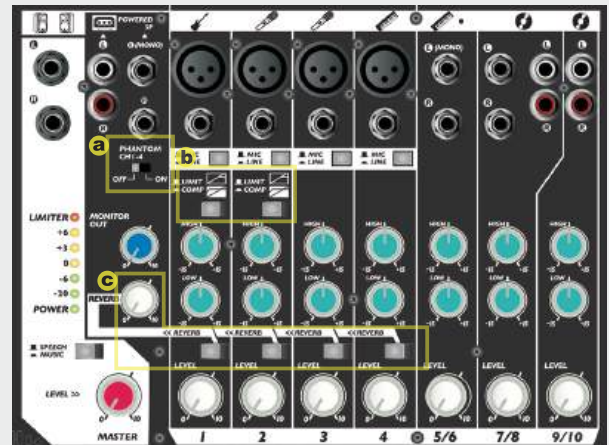

- a MUSIC/SPEECH switch: Ensures the sound system will have the ultimate vocal clarity in speech applications.
- b Reverb Processor: Adds reverberation to your mics and instruments on 4 mic/line channels.

- a Phantom Power: Provides 15V DC phantom power for condenser mics on 4 mic channels.
- b LIMIT/COMP switches: Provides limiting or compression to mic/line channels 1 and 2 for dynamic control.
- c DIGITAL REVERB: Adds high quality digital reverb, giving additional ambience to your sound source.

### Mixer Specifications

Model No.	SP108	SP110
Max. Output Power @10% THD at 1 kHz (Speaker L / R)	150 W + 150 W / 6 Ω	250 W + 250 W / 4 Ω
Output Power (RMS) @10% THD at 1 kHz (Speaker L / R)	100 W + 100 W / 6 Ω	200 W + 200 W / 4 Ω
Frequency Response	20-20 kHz	20-20 kHz
THD	≤0.5 % @20-20 kHz, +14 dBu	≤0.5 % @20-20 kHz, +14 dBu
Hum and Noise 20-20 kHz, Rs=150 Ω, MIC / LINE switch=MIC	≤ -67 dBu residual output noise (SPEAKER L / R)	≤ -64 dBu residual output noise (SPEAKER L / R)
Crosstalk (1 kHz)	≤ -88 dBu residual output noise (Monitor, Rec outputs)	≤ -87 dBu residual output noise (Monitor, Rec outputs)
Phantom Power	NA	Channel 1-4
Compressor / Limiter	NA	ON: Compressing; OFF: Limiting (Channel 1-2)
EQ on input channels	±15 dB, HIGH 10 kHz , LOW 100 Hz	±15 dB, HIGH 10 kHz , LOW 100 Hz
Power Requirements	115V / 60 Hz; 230V / 50 Hz	115V / 60 Hz; 230V / 50 Hz
AC Connector	Male IEC	Male IEC
Power Consumption	70 W	65 W
Net Weight (mixer and two speakers)	16.9 kg (37.2 lbs)	23 kg (50.7 lbs)
Dimensions	Speaker: 455 x 275 x 265 mm (H17.9 x W10.8 x D10.4 in.) Mixer: 95 x 290 x 160.5 mm (H3.7 x W11.4 x D6.3 in. )	Speaker: 545 x 343 x 300 mm (H21.5 x W13.5 x D11.8 in.) Mixer: 175 x 330 x 112 mm (H6.9 x W13 x D4.4 in.)

### Speaker Specifications

Enclosure	Bass-reflex type, PP, black	Bass-reflex type, PP, black
Speaker Driver	LF: 8" (20 cm) HF: 1" (2.54 cm) compression driver	LF: 10" (25.4 cm) HF: 1" (2.54 cm) compression driver
Crossover	4 kHz	4 kHz
Frequency Response (-10 dB)	55-20 kHz	52-20 kHz
Max. Output SPL	112 dB SPL	116 dB SPL
Optional Items	VT96 VHF wireless system (two handheld transmitters), MS432, microphone stand with adjustable height 52-140 cm and microphone stand adapter, SPS410AB light Aluminum speaker stand	

# Speakers

# SFD Series

## SF8D

### 8" Two-way Full-Range Speaker

Street buskers / Guitarist / Public speaker / Singer / Performers

Brand-new design class-D amplifier and switch-mode power supplier provide extremely high efficiency performance and light-weight portability. Extensive DSP processing is employed throughout, providing levels of sonic clarity, crossover, EQ, limiter and system protection. SF D-series give a new definition of powered speaker, and match the requirement of critical professional engineers.

- Lightweight portable active speakers with class-D amplifier and switch-mode power supply
- integrated 24-bit digital signal processor for ultimate system control and speaker protection
- Comfortable ergonomic handles
- Perform as main PA or stage monitors

#### Specifications

Type	8-inch, two way
LF Power Amp	100 W RMS (Class D) ; 160 W Peak
HFPower Amp	25 W RMS; 40 W Peak
Frequency Reponse (-10 dB)	62-20k Hz
Input Sensitivity	Line: 0.775 V (0 dBu)
Max. Peak SPL	120 dB SPL
Driver	LF: L8G Ferrite driver, 8" (200 mm) HF: H25G 1"(25.4 mm)
HF Horn Coverage Angles	H90° x V45°
Crossover Frequency	2.4k Hz
Input Impedance	Line: Bal: 66k Ω ; Unbal: 33k Ω Mic: 2k Ω
Angles for floor Monitor	45° & 55°
Mounting Method	Integral 1 3/8" Pole Mount Receptable
Suspension	4*M8 (2 on top, 2 on bottom)
Enclosure Material	PP
Finish	Black
Connectors	Input: XLR3F + 6.3 mm (combo), Loop Through: XLR3M
AC Connector	Male IEC
Indicaotrs	Power: Blue; Limit: Red; Standby:Green; Mic Level: Amber
Power Requirement	115V / 60 Hz, 230V / 50 Hz
Dimensions	H45.5 x W27.5 x D26.1 cm (H17.9 x W10.8 x D10.3 in.)
Net Weight	8 kg (17.6 lbs)

## SF10D

### 10" Two-way Full-Range Speaker

Street buskers / Guitarist / Public speaker / Singer / Performers

Brand-new design class-D amplifier and switch-mode power supplier provide extremely high efficiency performance and light-weight portability. Extensive DSP processing is employed throughout, providing levels of sonic clarity, crossover, EQ, limiter and system protection. SF D-series give a new definition of powered speaker, and match the requirement of critical professional engineers.

- Lightweight portable active speakers with class-D amplifier and switch-mode power supply
- integrated 24-bit digital signal processor for ultimate system control and speaker protection
- Comfortable ergonomic handles
- Perform as main PA or stage monitors

#### Specifications

Type	10-inch, two way
LF Power Amp	100 W RMS (Class D) ; 160 W Peak
HFPower Amp	25 W RMS; 40 W Peak
Frequency Reponse (-10 dB)	60-20k Hz
Input Sensitivity	Line: 0.775 V (0 dBu)
Max. Peak SPL	121 dB SPL
Driver	LF: L10G Ferrite driver, 10"(255mm) HF: H25G 1"(25.4mm)
HF Horn Coverage Angles	H90° x V45°
Crossover Frequency	2.4k Hz
Input Impedance	Line: Bal: 66k Ω ; Unbal: 33k Ω Mic: 2k Ω
Angles for floor Monitor	45° & 55°
Mounting Method	Integral 1 3/8" Pole Mount Receptable
Suspension	5*M8 (2 on top, 2 on bottom, 1 on rear)
Enclosure Material	PP
Finish	Black
Connectors	Input: XLR3F + 6.3 mm (combo), Loop Through: XLR3M
AC Connector	Male IEC
Indicaotrs	Power: Blue; Limit: Red; Standby:Green; Mic Level: Amber
Power Requirement	115V / 60 Hz, 230V / 50 Hz
Dimensions	H54.3 x W33.5 x D32.4 cm (H21.4 x W13.2 x D12.8 in)
Net Weight	10.2 kg (22.5 lbs)



## SF12D

### 12" Two-way Full-Range Speaker

Street buskers / Guitarist / Public speaker / Singer / Performers

Brand-new design class-D amplifier and switch-mode power supplier provide extremely high efficiency performance and light-weight portability. Extensive DSP processing is employed throughout, providing levels of sonic clarity, crossover, EQ, limiter and system protection. SF D-series give a new definition of powered speaker, and match the requirement of critical professional engineers.

- Lightweight portable active speakers with class-D amplifier and switch-mode power supply
- integrated 24-bit digital signal processor for ultimate system control and speaker protection
- Comfortable ergonomic handles
- Perform as main PA or stage monitors

#### Specifications

Type	12-inch, two way
LF Power Amp	200 W RMS (Class D) ; 320 W Peak
HFPower Amp	50 W RMS; 80 W Peak
Frequency Reponse (-10 dB)	55-20k Hz
Input Sensitivity	Line: 0.775 V (0 dBu)
Max. Peak SPL	125 dB SPL
Driver	LF: L12K Ferrite driver, 12" (304.8 mm) HF: H25G, 1"(25.4 mm)
HF Horn Coverage Angles	H90° x V45°
Crossover Frequency	2.4k Hz
Input Impedance	Line: Bal: 66k Ω; Unbal: 33k Ω Mic: 2k Ω
Angles for floor Monitor	45° & 55°
Mounting Method	Integral 1 3/8" Pole Mount Receptable
Suspension	5*M8 (2 on top, 2 on bottom, 1 on rear)
Enclosure Material	PP
Finish	Black
Connectors	Input: XLR3F + 6.3 mm (combo), Loop Through: XLR3M
AC Connector	Male IEC
Indicaotrs	Power: Blue; Limit: Red Standby: Green; Mic Level: Amber
Power Requirement	115V / 60 Hz, 230V / 50 Hz
Dimensions	H62.3 x W37.8 x D36.3 cm (H24.5 x W14.9 x D14.3 in.)
Net Weight	18 kg (39.7 lbs)

## SF15D

### 15" Two-way Full-Range Speaker

Street buskers / Guitarist / Public speaker / Singer / Performers

Brand-new design class-D amplifier and switch-mode power supplier provide extremely high efficiency performance and light-weight portability. Extensive DSP processing is employed throughout, providing levels of sonic clarity, crossover, EQ, limiter and system protection. SF D-series give a new definition of powered speaker, and match the requirement of critical professional engineers.

- Lightweight portable active speakers with class-D amplifier and switch-mode power supply
- integrated 24-bit digital signal processor for ultimate system control and speaker protection
- Comfortable ergonomic handles
- Perform as main PA or stage monitors

#### Specifications

Type	15-inch, two way
LF Power Amp	200 W RMS (Class D) ; 320 W Peak
HFPower Amp	50 W RMS; 80 W Peak
Frequency Reponse (-10 dB)	52-20k Hz
Input Sensitivity	Line: 0.775 V (0 dBu)
Max. Peak SPL	126 dB SPL
Driver	LF: L15K Ferrite driver, 15" (381 mm) HF: H25G, 1"(25.4 mm)
HF Horn Coverage Angles	H90° x V45°
Crossover Frequency	2.4k Hz
Input Impedance	Line: Bal: 66k Ω; Unbal: 33k Ω Mic: 2k Ω
Angles for floor Monitor	45° & 55°
Mounting Method	Integral 1 3/8" Pole Mount Receptable
Suspension	5*M8 (2 on top, 2 on bottom, 1 on rear)
Enclosure Material	PP
Finish	Black
Connectors	Input: XLR3F + 6.3 mm (combo), Loop Through: XLR3M
AC Connector	Male IEC
Indicaotrs	Power: Blue; Limit: Red Standby: Green; Mic Level: Amber
Power Requirement	115V / 60 Hz, 230V / 50 Hz
Dimensions	H70 x W47 x D41 cm (H27.5 x W18.5 x D16.1 in.)
Net Weight	21.5 kg (47.4 lbs)



## SF12DS

### 12" Active Subwoofer Speaker

Street buskers / Guitarist / Public speaker / Singer / Performers

Extending the SF-D series full-range speakers size-defying performance and sleek styling into the low-end realm, the packs 700 W of self-powered punch into a low-profile wood enclosure. Match full-range speaker with subwoofer and hear just how big a small rig can sound, whether you want to add a tight thump to a DJ set or give the highs and mids some breathing room in a live performance.

- High power 700W (RMS), class-D
- Powerful, engaging bass response
- Integrated 24-bit digital signal processor for ultimate system control and speaker protection
- Switchable EQ modes for different applications
- Pole mount for full-range systems

#### Specifications

Type	12-inch subwoofer speaker
Power Amp	700 W (Class D), RMS
Frequency Response (-10 dB)	44-118 Hz
Input Sensitivity	Line: 0.775 V (0 dBu)
Max. Peak SPL	126 dB SPL
Crossover Frequency	100 Hz
Input type	Balanced differential line
Input Impedance	20k $\Omega$
Driver	L12N Ferrite Driver 12" (304.8 mm), 2.5" coil
Enclosure Material	MDF, 15 mm
Finish	Black
Connector	Input: XLR3F, Output: XLR3M
AC Connector	Male IEC
Indicators	Power: Red; Limit: Red
Power Requirement	115 V / 60 Hz, 230 V / 50 Hz
Dimensions	H400 x W444.5 x D465 mm (H15.7 x W17.5 x D18.3 in)
Net Weight	20.4 kg (45 lbs)



## SF15DS

### 15" Active Subwoofer Speaker

Street buskers / Guitarist / Public speaker / Singer / Performers

Extending the SF-D series full-range speakers size-defying performance and sleek styling into the low-end realm, the packs 700 W of self-powered punch into a low-profile wood enclosure. Match full-range speaker with subwoofer and hear just how big a small rig can sound, whether you want to add a tight thump to a DJ set or give the highs and mids some breathing room in a live performance.

- High power 700W (RMS), class-D
- Powerful, engaging bass response
- Integrated 24-bit digital signal processor for ultimate system control and speaker protection
- Switchable EQ modes for different applications
- Pole mount for full-range systems

#### Specifications

Type	15-inch subwoofer speaker
Power Amp	700 W (Class D), RMS
Frequency Response (-10 dB)	40-118 Hz
Input Sensitivity	Line: 0.775 V (0 dBu)
Max. Peak SPL	127 dB SPL
Crossover Frequency	100 Hz
Input type	Balanced differential line
Input Impedance	20k $\Omega$
Driver	L15N Ferrite Driver 15" (381 mm), 2.5" coil
Enclosure Material	MDF, 18 mm
Finish	Black
Connector	Input: XLR3F, Output: XLR3M
AC Connector	Male IEC
Indicators	Power: Red; Limit: Red
Power Requirement	115 V / 60 Hz, 230 V / 50 Hz
Dimensions	H505 x W580 x D600 mm (H19.8 x W22.8 x D23.6 in)
Net Weight	29 kg (64 lbs)



## SF18DS

### 18" Active Subwoofer Speaker

Street buskers / Guitarist / Public speaker / Singer / Performers

Extending the SF-D series full-range speakers size-defying performance and sleek styling into the low-end realm, the packs 700 W of self-powered punch into a low-profile wood enclosure. Match full-range speaker with subwoofer and hear just how big a small rig can sound, whether you want to add a tight thump to a DJ set or give the highs and mids some breathing room in a live performance.

- High power 700W (RMS), class-D
- Powerful, engaging bass response
- Integrated 24-bit digital signal processor for ultimate system control and speaker protection
- Switchable EQ modes for different applications
- Pole mount for full-range systems

#### Specifications

Type	18-inch subwoofer speaker
Power Amp	700 W (Class D), RMS
Frequency Response (-10 dB)	35-110 Hz
Input Sensitivity	Line: 0.775 V (0 dBu)
Max. Peak SPL	130 dB SPL
Crossover Frequency	100 Hz
Input type	Balanced differential line
Input Impedance	20k $\Omega$
Driver	L18N Ferrite Driver 18" (460 mm), 3" coil
Enclosure Material	MDF, 18 mm
Finish	Black
Connector	Input: XLR3F, Output: XLR3M
AC Connector	Male IEC
Indicators	Power: Red; Limit: Red
Power Requirement	115 V / 60 Hz, 230 V / 50 Hz
Dimensions	H550 x W670 x D700 mm (H21.6 x W26.3 x D27.5 in)
Net Weight	34 kg (74.9 lbs)



SF10D + SF15DS

SF12D + SF18DS

SF8D + SF12DS

# Flagship Speakers

## SF Series

### DESIGNED FOR PERFORMANCE

This speaker series has been carefully designed from the ground up to ensure that all of the necessary components for a portable system will work together in the most efficient manner, not only providing increased performance levels but also reliability. These design improvements have extended also into the construction of the speakers, making them sturdier than ever and tough enough to handle the impacts incurred by road use. The SF series will satisfy the demand by professional users for a 3-way speaker system that is light weight, portable and tough while also delivering superior sound quality.

### LOW FREQUENCY

The low frequency driver with neodymium magnet is light but can deliver a smooth frequency response while handling very high sound pressure levels. The large diameter voice coil offers not only efficiency, but exceptionally low distortion for truly clean lows.

### HIGH FREQUENCY

Featuring a high quality voice coil, the HF compression driver is used to deliver crystal clear highs. The 90°x45° directivity waveguide horn ensures broad, consistent coverage over the entire audience area.

### RELIABILITY

All Superlux loudspeakers must endure extremely tough testing, including an overload test, to ensure years of reliable service. Active models' large integrated diecast heat-sinks, offering an exceptionally efficient cooling system, combined with built-in HF and LF protective circuitry and an extremely rugged composite enclosure with metal grille, ensure that all Superlux loudspeakers can withstand the rigors of road abuse.

### EASY TO HANDLE

The SF series has been designed for maximum ease in handling from storage to the back of your car to the gig or the stage. Through careful modeling and real-life testing, handle locations have been positioned at the exact balance points, ensuring easy handling when carrying these speakers. The molded cabinets have one handle on top and one handle on the side, making it equally easy to place the loudspeaker on a tripod stand or into the back of your car.

### VERSATILE PLACEMENT

The SF series is everything you could need in a versatile loudspeaker system. With enclosures that feature both 45° and 55° angle sides and flexible connectivity, these loudspeakers are equally useful either as a main speaker or a low-profile monitor. A standard pole mount socket with stabilizing screw and built-in non-slip rubber feet allow both secure stand mounting and free standing configurations. Integrated standard.

- Both passive and active versions are available in the SF series
- Neodymium transducer provides incredibly deep bass and acoustic power
- High-output precision titanium compression driver
- One piece structure of rear panel and heat-sink provides optimized cooling
- Molded composite cabinet is lightweight for ultimate portability
- 45° and 55° angles for aiming up toward performers when used as a floor monitor
- Flyable, pole mountable, floor wedge-able, stackable and wall mountable



## SF118AS

### 18" Active Subwoofer Speaker

Street buskers / Guitarist / Public speaker / Singer / Performers

If you prefer to have a deeper and extended low frequency response while using the SF series speakers, then the SF118AS is the right choice for you. It offers a high energy boost to those low frequencies, giving your sound that extra punch.

- Professional 18-inch active subwoofer speaker
- High power 500W (RMS), class-D
- Volume control and loop through output
- Protection circuitry with limiter
- 35 mm pole mount socket



SF118AS  
Control and connecting panel



SF110A, SF112A, SF115A  
Control and connecting panel

### Specifications

Type	18-inch subwoofer speaker
Power Amp	500 W (Class D), RMS
Frequency Response (-10 dB)	38-135 Hz
Input Sensitivity	Line: 0.775 V (0 dBu)
Max. Peak SPL	131 dB SPL
Crossover Frequency	100 Hz
Input Type	Balanced differential line
Impedance	Input: 23 kΩ, Output: 280 Ω
Driver	L18AS Ferrite Driver 18" (457.2 mm), 4" coil
Enclosure Material	MDF
Finish	Black
Connectors	Input: XLR3F, Output: XLR3M, Loop Through: XLR3M
AC Connector	Male IEC
Indicators (on rear)	Power: Green; Overload: Red
Power Requirements	115V / 60 Hz; 230V / 50 Hz
Dimensions	H64 x W55 x D53 cm (H25.5 x W22 x D21 in.)
Net Weight	42.7 kg (94 lbs)
Optional Accessories	SPA01 subwoofer pole



## SF110A

### 10" Active Full-Range Speaker

#### Street buskers / Speaker / Performers

The SF110A is a brand-new design in a molded speaker system, bringing a totally different experience in portable sound. High efficiency, high power, high penetration and tailored vocal sound profile make SF110A a perfect tool for sound reinforcement system.

- 200W power amp
- 2-way bi-amplified, optimized active speaker system
- LF transducer provides incredibly deep bass and acoustic power
- High-output precision titanium compression driver
- XLR Mic input and Combo (XLR + 1/4") Line input, and 1/4" mixed output
- Molded composite cabinet is lightweight for ultimate portability
- 45° and 55° angles for aiming up toward performers when used as a floor monitor
- Flyable, pole mountable, floor wedge-able and wall mountable

#### Specifications

Model No.	SF110A	SF112A	SF115A
Type	10-inch, two-way	12-inch, two-way	15-inch, two-way
Frequency Response (-10 dB)	60-18 kHz	50-15 kHz	45-15 kHz
Max. Peak SPL	122 dB SPL	128 dB SPL	129 dB SPL
Driver	LF: L10G ferrite, 10" (254 mm) HF: H25F, 1" (25 mm)	LF: L12FN ferrite, 12" (304 mm) HF: H44F, 1.75" (44 mm)	LF: L15FN ferrite, 15" (381 mm) HF: H44F, 1.75" (44 mm)
HF Horn Coverage Angles	H90° x V45°	H90° x V45°	H90° x V45°
Mounting Method	Integral 1 3/8" pole mount receptacle	Integral 1 3/8" pole mount receptacle	Integral 1 3/8" pole mount receptacle
Suspension	5 x M8 (2 on top, 2 on bottom, 1 on rear)	5 x M8 (2 on top, 2 on bottom, 1 on rear)	5 x M8 (2 on top, 2 on bottom, 1 on rear)
Enclosure Material	PP	PP	PP
Finish	Black	Black	Black
LF Power Amp	150 W (Class AB), RMS	300 W (Class D), RMS	300 W (Class D), RMS
HF Power Amp	50 W (Class AB), RMS	100 W (Class AB), RMS	100 W (Class AB), RMS
Input Sensitivity	Line: 1.23 V (+4 dBu)	Line: 1.23 V (+4 dBu)	Line: 1.23 V (+4 dBu)
Crossover Frequency	2.4 kHz	2.4 kHz	2.4 kHz
Input Impedance	Line: 20 kΩ Mic: 2 kΩ	Line: 20 kΩ Mic: 2 kΩ	Line: 20 kΩ Mic: 2 kΩ
Connectors	Input: XLR3F (Mic), Combo (XLR + 1/4") (Line); Mixed output: 1/4"	Input: XLR3F (Mic), Combo (XLR + 1/4") (Line); Mixed output: 1/4"	Input: XLR3F (Mic), Combo (XLR + 1/4") (Line); Mixed output: 1/4"
AC Connector	Male IEC	Male IEC	Male IEC
Indicators	Front: White-Power; Rear: Power-Green; Overload: Red	Front: White-Power; Rear: Power-Green; Overload: Red	Front: White-Power; Rear: Power-Green; Overload: Red
Power Requirements	115V / 60 Hz; 230V / 50 Hz	115V / 60 Hz; 230V / 50 Hz	115V / 60 Hz; 230V / 50 Hz
Dimensions (H x W x D)	54.3 x 33.5 x 32.4 cm (21.4 x 13.2 x 12.8 in.)	62.3 x 37.8 x 36.3 cm (24.5 x 14.9 x 14.3 in.)	70 x 47 x 41 cm (27.5 x 18.5 x 16.1 in.)
Net Weight	12 kg (26.4 lbs)	19.5 kg (43 lbs)	22 kg (48.5 lbs)
Optional Accessories	SPS410B speaker stand, A x 110 U-bracket mounting kit	SPS410B speaker stand, A x 112 U-bracket mounting kit	SPS410B speaker stand, A x 115 U-bracket mounting kit



## SF112A

### 12" Active Full-Range Speaker

#### Street buskers / Speaker / Performers

The SF112A is a brand-new design in a molded speaker system, bringing a totally different experience in portable sound. Combined with 12" molded powered subwoofer to form a 3-way full molded speaker system and provide powerful and deep sound. Integrated die-cast heatsink, it offers ultimate convection cooling system. High efficiency, high power, high penetration and tailored vocal sound profile make SF112A a perfect tool for sound reinforcement system.

- 400W power amp
- 2-way bi-amplified, optimized active speaker system
- Built-in active crossover with 24 dB/oct 4th order, Mic / line input and loop output
- Neodymium transducer provides incredibly deep bass and acoustic power
- High-output precision titanium compression driver
- One piece structure of rear panel and heat-sink provides optimized cooling
- Molded composite cabinet is lightweight for ultimate portability
- 45° and 55° angles for aiming up toward performers when used as a floor monitor
- Flyable, pole mountable, floor wedge-able, stackable and wall mountable



## SF115A

### 15" Active Full-Range Speaker

#### Street buskers / Speaker / Performers

The SF115A is a brand-new design in a molded speaker system, bringing a totally different experience in portable sound. Combined with 15" molded powered subwoofer to form a 3-way full molded speaker system and provide powerful and deep sound. Integrated die-cast heatsink, it offers ultimate convection cooling system. High efficiency, high power, high penetration and tailored vocal sound profile make SF115A a perfect tool for sound reinforcement system.

- 400W power amp
- 2-way bi-amplified, optimized active speaker system
- Built-in active crossover with 24 dB/oct 4th order, Mic / line input and loop output
- Neodymium transducer provides incredibly deep bass and acoustic power
- High-output precision titanium compression driver
- One piece structure of rear panel and heat-sink provides optimized cooling
- Molded composite cabinet is lightweight for ultimate portability
- 45° and 55° angles for aiming up toward performers when used as a floor monitor
- Flyable, pole mountable, floor wedge-able, stackable and wall mountable

# Best Value Speakers

# SF Series



## SF12AS & SF15AS 12" & 15" Active Subwoofer Speakers

The SF Best Value Series inherits the SF Flagship Series high performance and versatile enclosure. It comes in 10-inch, 12", and 15-inch full range speakers in passive and active versions, and 12" and 15" active subwoofers, making it possible to form a complete 3-way system with molded enclosures whose extended low frequency response and solid bass give an unmatched musical sound profile. Active full range speakers feature a dedicated 2-band EQ for perfect sound adjustment and the studio-quality microphone preamp ensures excellent vocal sound. Built-in protection circuitry protects the power amplifier and speaker drivers to ensure dependability. This series is also suitable for side-fill or floor monitor applications. They are pole mountable, floor wedge-able, stackable and wall mountable, making the SF series perfect for portable sound system or installation applications. The SF series was created to satisfy professionals' requirements, whether used in disco pubs, small/medium concerts, lectures or presentations.

- Both passive and active versions are available in the SF series
- Full-range Speakers
- High sensitivity long-throw low frequency transducer provides incredibly deep bass and acoustic power
- High-output precision titanium compression driver
- Molded composite cabinet is lightweight for ultimate portability
- Ergonomically shaped handles for easy carrying and setup 45° and 55° angles for aiming up toward performers when used as a floor monitor
- Ultra-wide, smooth sound dispersion
- Additional link output allows linking of additional speakers to the system
- Flyable, pole mountable, floor wedge-able, stackable and wall mountable

Street buskers / Guitarist / Public speaker / DJ / Performers

The Superlux molded powered subwoofer is the ideal solution where big sound and compact portability are required. Combining the amazing low-frequency performance of a subwoofer driver with high-efficiency 500 Watt amplifier channel and an electronic crossover, the SF12AS and SF15AS eliminate the need for a separate crossover to drive a full-range system. Through the satellite speaker output, the performance match active full range speaker can be connected to subwoofer speaker. A line level XLR output is also provided for daisy chaining to powered speakers or additional power amps. Combining with full range speaker, the active speaker creates an extended low frequency response and comes a big full sound from a very small package. The result is a compact, self-contained 3-way system that sounds much bigger than it looks.

- Professional active subwoofer speakers
- 500W (RMS) Class-D power amplifiers
- Very compact and lightweight: only 20.4kg (44.9 lbs) Integral handle
- Aluminum cast frame high power subwoofer driver
- Integral limit and protection circuitry
- XLR line level outputs for loop through and satellite output

Best value in a portable speaker system for a variety of applications

### DISCO / PUB

A pair of SF12A and a pair of SF12AS, or a pair of SF15A and a pair of SF15AS



### SMALL CONCERT

A pair of SF12A and a SF12AS, or a pair of SF15A and a SF15AS



### PRESENTATIONS

A pair of SF12A, or a pair of SF15A and a SF15AS



## Specifications

Model No.	SF12AS	SF15AS
Type	12-inch subwoofer	15-inch subwoofer
Frequency Response (-10 dB)	43-275 Hz	40-275 Hz
Max. Peak SPL	128 dB SPL	128 dB SPL
Driver	LF: L12E ferrite driver, 12" (305 mm); HF: H34G, 1.34" (34 mm)	LF: L15E ferrite driver, 15" (381 mm); HF: H34G, 1.34" (34 mm)
Mounting Method	Integral 1 3/8" pole mount receptacle	
Suspension	5 x M8 (2 on top, 2 on bottom, 1 on rear)	
Enclosure Material	PP	PP
Finish	Black	Black
LF Power Amp	500 W (Class D), RMS	500 W (Class D), RMS
Input Sensitivity	Line: 0.775 V (0 dBu)	Line: 0.775 V (0 dBu)
Crossover	100 Hz	100 Hz
Input Impedance	Line: 23 kΩ	
Connectors	Input: XLR3F; Output: XLR3M; Link Out: XLR3M	
AC Connector	Male IEC	Male IEC
Indicators (on rear)	Green: Power; Red: Overload	
Power Requirements	115V / 60 Hz; 230V / 50 Hz	115V / 60 Hz; 230V / 50 Hz
Dimensions (H x W x D)	62.3 x 37.8 x 36.3 cm (24.5 x 14.9 x 14.3 in.)	70 x 47 x 41 cm (27.5 x 18.5 x 16.1 in.)
Net Weight	20.2 kg (44.5 lbs)	23.5 kg (51.8 lbs)



SF12AS, SF15AS  
Control and connecting panel



SF10A, SF12A, SF15A  
Control and connecting panel



## SF10A

### 10" Active Full-Range Speaker

Music Appreciation / DJ / Performers

SF10A, 10-inch active full range speaker features a dedicated 2-band EQ for perfect sound adjustment and the studio-quality microphone preamp ensures excellent vocal sound. Built-in protection circuitry protects the power amplifier and speaker drivers to ensure dependability. The SF10A is also suitable for side-fill or floor monitor applications. It is pole mountable, floor wedge-able, stackable and wall mountable, making the SF10A perfect for portable sound system or installation applications.

- 200 W power amplifier
- 2-way bi-amplified, optimized active speaker system
- Integrated signal processor for ultimate system control and speaker protection
- Extremely low noise Mic / Line input with volume control and LED clip indicator
- Dedicated 2-band EQ for perfect sound adjustment

#### Specifications

Type	10-inch, two-way	12-inch, two-way	15-inch, two-way
Frequency Response (-10 dB)	60-20 kHz	55-20 kHz	52-20 kHz
Max. Peak SPL	122 dB SPL	125 dB SPL	124 dB SPL
Driver	LF: L10G ferrite driver, 10" (254 mm) HF: H34G, 1.34" (34 mm)	LF: L12G ferrite driver, 12" (305 mm) HF: H34G, 1.34" (34 mm)	LF: L15G ferrite driver, 15" (381 mm) HF: H34G, 1.34" (34 mm)
HF Horn Coverage Angles	H90° x V45°	H90° x V45°	H90° x V45°
Mounting Method	Integral 1 3/8" pole mount receptacle	Integral 1 3/8" pole mount receptacle	Integral 1 3/8" pole mount receptacle
Suspension	5 x M8 (2 on top, 2 on bottom, 1 on rear)	5 x M8 (2 on top, 2 on bottom, 1 on rear)	5 x M8 (2 on top, 2 on bottom, 1 on rear)
Enclosure Material	PP	PP	PP
Finish	Black	Black	Black
LF Power Amp	100 W RMS (Class AB); 160 W Peak	200 W RMS (Class AB); 320 W Peak	200 W RMS (Class AB); 320 W Peak
HF Power Amp	25 W (Class AB); 40 W Peak	50 W (Class AB); 80 W Peak	50 W (Class AB); 80 W Peak
Input Sensitivity	Line: 1.23 V (+4 dBu)	Line: 1.23 V (+4 dBu)	Line: 1.23 V (+4 dBu)
Crossover	2.4 kHz	2.4 kHz	2.4 kHz
EQ or HPF	12 kHz / ±15dB; 80 Hz / ±15dB	12 kHz / ±15 dB; 80 Hz / ±15 dB	12 kHz / ±15dB; 80 Hz / ±15dB
Input Impedance	Line: 20 kΩ, Mic: 2 kΩ	Line: 20 kΩ, Mic: 2 kΩ	Line: 20 kΩ, Mic: 2 kΩ
Connectors	Input: XLR3F & 1/4" (6.3 mm); Link Out: XLR3M	Input: XLR3F & 1/4" (6.3 mm); Link Out: XLR3M	Input: XLR3F & 1/4" (6.3 mm); Link Out: XLR3M
AC Connector	Male IEC	Male IEC	Male IEC
Indicators (on rear)	Green: Power; Red: Overload	Green: Power; Red: Overload	Green: Power; Red: Overload
Power Requirements	115V / 60 Hz; 230V / 50 Hz	115V / 60 Hz; 230V / 50 Hz	115V / 60 Hz; 230V / 50 Hz
Dimensions (H x W x D)	53 x 33.5 x 32 cm (20.7 x 13.19 x 12.6 in.)	62.3 x 37.8 x 36.3 cm (24.5 x 14.9 x 14.3 in.)	70 x 47 x 41 cm (27.5 x 18.5 x 16.1 in.)
Net Weight	14.5 kg (31.9 lbs)	20 kg (44 lbs)	27 kg (59.5 lbs)
Optional Accessories	SPS410B speaker stand, A x 110 U-bracket mounting kit	SPS410B speaker stand, A x 112 U-bracket mounting kit	SPS410B speaker stand, A x 115 U-bracket mounting kit



## SF12A

### 12" Active Full-Range Speaker

Music Appreciation / DJ / Performers

SF12A, 12-inch active full range speaker features a dedicated 2-band EQ for perfect sound adjustment and the studio-quality microphone preamp ensures excellent vocal sound. Built-in protection circuitry protects the power amplifier and speaker drivers to ensure dependability. The SF12A is also suitable for side-fill or floor monitor applications. It is pole mountable, floor wedge-able, stackable and wall mountable, making the SF12A perfect for portable sound system or installation applications. The SF12A was created to satisfy professionals' requirements, whether used in disco pubs, small/medium concerts, lectures or presentations.

- 400 W power amplifier
- 2-way bi-amplified, optimized active speaker system
- Integrated signal processor for ultimate system control and speaker protection
- Extremely low noise Mic / Line input with volume control and LED clip indicator
- Dedicated 2-band EQ for perfect sound adjustment



## SF15A

### 15" Active Full-Range Speaker

Music Appreciation / DJ / Performers

SF15A, 15-inch active full range speaker features a dedicated 2-band EQ for perfect sound adjustment and the studio-quality microphone preamp ensures excellent vocal sound. Built-in protection circuitry protects the power amplifier and speaker drivers to ensure dependability. The SF15A is also suitable for side-fill or floor monitor applications. It is pole mountable, floor wedge-able, stackable and wall mountable, making the SF15A perfect for portable sound system or installation applications. The SF15A was created to satisfy professionals' requirements, whether used in disco pubs, small/medium concerts, lectures or presentations.

- 400 W power amplifier
- 2-way bi-amplified, optimized active speaker system
- Integrated signal processor for ultimate system control and speaker protection
- Extremely low noise Mic / Line input with volume control and LED clip indicator
- Dedicated 2-band EQ for perfect sound adjustment



## SF8

### 8" Two-way, Passive Speaker

Live Sound / Speech / Playback / DJ / A/V / Institutional Venues

The SF8 set a best value for passive speakers. Their design provide the user an easy to use, reliable HF protection circuit and high power handling in a very compact, attractive package. Both of them are full range loudspeaker ideal for applications requiring high-quality sound. Careful attention to the dynamic requirements of music guided the design to provide high SPL. Built-in pole mount and optional rigging hardware make it easy to position for your application. The high-frequency section of the SF8 utilizes an integrated 90° x 45° horn to ensure high intelligibility. Vocals sound natural yet “cut through” reverberant, noisy rooms. The SF8 high-frequency horn is driven by the H25G, a 1 inch diaphragm, wide-bandwidth, titanium-diaphragm driver for smooth and extended high-frequency response.

- High power handling: 150W RMS; 600W peak
- High-output precision titanium compression driver
- High sensitivity long-throw low frequency transducer provides incredibly deep bass and acoustic power
- Ultra-wide, smooth dispersion
- Overload-protection circuitry ensures optimal HF driver protection
- Additional link output allows linking of additional speaker systems
- Molded composite cabinet with lightweight for ultimate portability
- Ergonomically shaped handles for easy carrying and setup 45° or 55° angles for aiming up toward performers when used as a loor monitor
- Flyable, pole mountable, floor wedge-able, and wall mountable

#### Specifications

Type	8-inch, two-way
Power Handling RMS/Peak	150 W / 600 W
Frequency Response (-10 dB)	62 Hz - 20k Hz
Rated Impedance	8 Ω
Sensitivity @1W/1m	93 dB SPL
Max. Peak SPL	120 dB
Crossover	3.5 k Hz
Protection	Internal overload Lamp on HF driver
Connectors	1 x Speakon-style + 1 x 1/4"
HF Horn Coverage, Angles (-6 dB)	90°H x 45°V
Suspension	4 x M8 (2 on top, 2 on bottom)
Angles for floor Monitor	45° & 55°
Mounting Method	Integral 1 3/8" Pole Mount Receptacle
Enclosure Material	PP
Finish	Black
Transducers / Replacement Parts	LF: L8G Ferrite driver, 8" (20.3 mm) HF: H25G, 1" (25 mm)
Dimensions (H x W x D)	45.5 x 27.5 x 26.1 cm (17.9 x 10.8 x 10.3 in.)
Net Weight	6.2 kg (13.6 lbs)
Shipping Weight	8.2 kg (18.1 lbs)



## SF8A

### 8" Active Full-Range Speaker

Live Sound / Speech / Playback / DJ / A/V / Institutional Venues

SF8A, 8-inch active full range speaker features a dedicated 2-band EQ for perfect sound adjustment and the studio-quality microphone preamp ensures excellent vocal sound. Built-in protection circuitry protects the power amplifier and speaker drivers to ensure dependability. The SF8A is also suitable for side-fill or floor monitor applications. It is pole mountable, floor wedge-able, stackable and wall mountable, making the SF8A perfect for portable sound system or installation applications.

- Full-range Speaker, 200 W power amplifier
- 2-way bi-amplified, optimized active speaker system
- Integrated signal processor for ultimate system control and speaker protection
- Extremely low noise Mic / Line input with volume control and LED clip indicator
- Dedicated 2-band EQ for perfect sound adjustment
- High sensitivity long-throw low frequency transducer provides incredibly deep bass and acoustic power
- High-output precision titanium compression driver
- Molded composite cabinet is lightweight for ultimate portability
- Ergonomically shaped handles for easy carrying and setup 45° and 55° angles for aiming up toward performers when used as a floor monitor
- Ultra-wide, smooth sound dispersion
- Additional link output allows linking of additional speakers to the system
- Flyable, pole mountable, floor wedge-able, stackable and wall mountable

#### Specifications

Type	8-inch, two-way
Frequency Response (-10 dB)	60-20 kHz
Max. Peak SPL	120 dB SPL
Driver	LF: L8G ferrite driver, 8" (20.3 mm), HF: H25G, 1" (25.4 mm)
HF Horn Coverage Angles	H90° x V45°
Mounting Method	Integral 1 3/8" pole mount receptacle
Suspension	5 x M8 (2 on top, 2 on bottom, 1 on rear)
Enclosure Material	PP
Finish	Black
LF Power Amp	100 W RMS (Class D); 160 W Peak
HF Power Amp	25 W (Class AB); 40 W Peak
Input Sensitivity	Line: 1.23 V (+4 dBu)
Crossover	2.4 kHz
EQ or HPF	12 kHz / ±15dB; 80 Hz / ±15dB
Input Impedance	Line: 20 kΩ, Mic: 2 kΩ
Connectors	Input: XLR3F & 1/4" (6.3 mm); Link Out: XLR3M
AC Connector	Male IEC
Indicators (on rear)	Green: Power; Red: Overload
Power Requirements	115V / 60 Hz; 230V / 50 Hz
Dimensions (H x W x D)	45.5 x 27.5 x 26.1 cm (17.9 x 10.8 x 10.3 in.)
Net Weight	8 kg (17.6 lbs)

# Portable Speakers

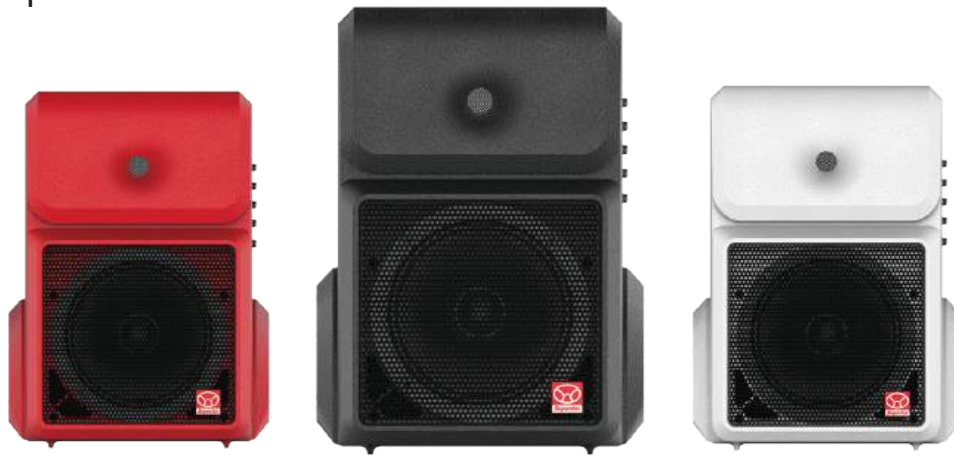

## SE108

### Multi-Functional Portable Speaker

Street Performance / Market Place / Street / Park / Classroom / Outdoor Speech / House Party

SE108 overcomes the bulky characteristic of the traditional speakers and provides ultra portability. The backpack element of SE108 fully reflects its personality and the design concepts. The built-in wireless microphone system and Bluetooth technology will free your hands and provide easy connection with any devices without constraints of cables.

- Light-weighted and easy portability. Backpack aesthetic design
- Easy to use and operate
- With headphone monitor output jack
- With two TRS jack inputs and separated volume control
- Built-in Bluetooth function. Bluetooth 4.1 technology for more convenient music input connection
- With REVERB function
- The two-stage hidden EQ can adjust the treble and bass sound quality perfectly
- Battery use for more than 5 hours

## SE108W

### Multi-Functional Portable Speaker

Street Performance / Market Place / Street / Park / Classroom / Outdoor Speech / House Party

SE108W overcomes the bulky characteristic of the traditional speakers and provides ultra portability. The backpack element of SE108W fully reflects its personality and the design concepts. The built-in wireless microphone system and Bluetooth technology will free your hands and provide easy connection with any devices without constraints of cables.

- Light-weighted and easy portability. Backpack aesthetic design
- Easy to use and operate
- With headphone monitor output jack
- With two TRS jack inputs and separated volume control
- Built-in Bluetooth function. Bluetooth 4.1 technology for more convenient music input connection
- With REVERB function
- The two-stage hidden EQ can adjust the treble and bass sound quality perfectly
- Furnished with an U channel wireless microphone
- Battery use for more than 5 hours



Wired / Wireless Monitor Headsets

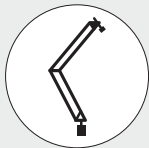

Extension arm Clip for mobile phone



6.3 mm Input



6.3 mm Input



Mic Stand Speaker Stand



3.5 mm-3.5 mm AUX Input

SE108 / SE108W Connection Device

### Specifications

Driver	LF: 8" / HF: 1" compression driver
LF Power Amp	40W
Frequency Response (-10 dB)	55-20 kHz
Input Sensitivity	Mic: -38 dBu / Line: 0 dBu
Max. Peak SPL	110 dB SPL
Crossover	4k Hz
Input	6.3 mm LINE IN & MIC, 3.5 mm AUX IN
Impedance	MIC=1.65KΩ / LINE=22.5KΩ
Enclosure Material	PP
Output	Headphone out
RMS Output Power	40W/4Ω (@THD<1% at 1KHz)
Total Harmonic Distortion	≤0.3% @20-20,000Hz, +14 dBu
Charging Requirement	12V / 7.5AH (Charger included)
Dimensions ( H x W x D )	441 x 330 x 262 mm (17.3 x 12.9 x 10.3 in.)
NET Weight	10 kg (22 lbs)



# Karaoke Speakers

# SK Series



## SK110 KARAOKE Speaker

### KTV Night Club / Entertainment Places

SK110 deliver mid-range vocal with high clarity and much deeper bass keeping the power but showing much variety of the bass details, which is the best choice of the KTV room.

- SK110 are comprised of a 10" woofer for low distortion, and a 1.76" diameter neodymium compression driver for tweeter
- Interior cabinet structure design delivers more power and strength of the bass
- The rating power reaches 300W RMS
- High-end passive crossover design eliminates the overlapping of the frequency as much as possible
- The enclosure is made of high quality plywood with 15mm thickness and wearproof finish
- The speaker panel is equipped with 1 standard speaker loop through jack
- The cabinet is integrated with 9 x M10 suspension points, and 4 x M10 installation points for KTV hanging installation use
- SK110 deliver mid-range vocal with high clarity and much deeper bass keeping the power but showing much variety of the bass details, which is the best choice of the KTV room

### Specifications

Type	10-inch two-way
Frequency Response	90-20 kHz
Sensitivity	95 dB
Rated Impedance	8 Ω
Max. SPL	122 dB
Power Handling (RMS)	300 W
Dispersing Angle	H70° × V100°
LF Driver	10 inch
HF Driver	H34C 1.76" (34 mm)
Suspension	1" Speakon-Style Connectors
Enclosure Material	15 mm plywood
Dimensions (H × W × D)	
Net Weight	

## SK112 KARAOKE Speaker

### KTV Night Club / Entertainment Places

SK112 deliver mid-range vocal with high clarity and much deeper bass keeping the power but showing much variety of the bass details, which is the best choice of the KTV room.

- SK112 are comprised of a 12" woofer for low distortion, and a 1.76" diameter neodymium compression driver for tweeter
- Interior cabinet structure design delivers more power and strength of the bass
- The rating power reaches 300W RMS
- High-end passive crossover design eliminates the overlapping of the frequency as much as possible
- The enclosure is made of high quality plywood with 15mm thickness and wearproof finish
- The speaker panel is equipped with 1 standard speaker loop through jack
- The cabinet is integrated with 9 x M10 suspension points, and 4 x M10 installation points for KTV hanging installation use
- SK112 deliver mid-range vocal with high clarity and much deeper bass keeping the power but showing much variety of the bass details, which is the best choice of the KTV room

### Specifications

Type	12-inch two-way
Frequency Response	90-20kHz
Sensitivity	97 dB
Rated Impedance	8 Ω
Max. SPL	124 dB
Power Handling (RMS)	350 W
Dispersing Angle	H70° × V60°
LF Driver	12 inch
HF Driver	H34C 1.76" (34 mm)
Suspension	2" Speakon-Style Connectors
Enclosure Material	15 mm plywood
Dimensions (H × W × D)	
Net Weight	

# Monitor Speakers

# BES Series



## BES3.5

### 3.5" Two-way monitor speaker

Project / Home Studio / Near Field Monitoring / DAW workstation / Home Theaters

The BES series is Superlux's latest offering designed specifically for personal studios and multi-purpose audio applications, available in two options: 3.5-inch and 5-inch models.

The BES3.5 is a 3.5-inch two-way monitor system that includes one active and one passive speaker, combining high-accuracy sound quality with flexible connectivity options. Ideal for music production, video editing, and daily listening, the BES3.5 delivers exceptional sound detail, ensuring accurate reproduction across all frequencies. Its sleek design and durable construction make it a reliable choice for various environments.

With multiple connection options, including TRS and 1/8-inch inputs, the BES3.5 easily integrates with a wide range of audio devices. Additionally, it features high and low-frequency gain and attenuation controls to better adapt to different room environments and speaker placements.

- 3.5" Woofer and 1" Tweeter: Delivers powerful, deep bass and crisp, clear highs, ensuring a balanced sound across the entire frequency range
- 50-Watt Output Power: Perfectly suited for various audio needs, ideal for both desktop and near-field monitoring environments
- Multiple Connectivity Options: Supports TRS and 1/8" inputs, effortlessly compatible with a wide range of audio devices
- Rear Volume control: Convenient for users to quickly adjust volume, enhancing ease of use and overall experience

### Specifications

Crossover Frequency	3 KHz
Max. SPL	100 dB SPL
Frequency Response (-3 dB)	80 - 20 KHz
Impedance	10k Ω
LF	3.5 in.
HF	1 in. Cloth Diaphragm
Enclosure Material	Wood
Input Impedance	Bal: 1/4" TRS Unbal: RCA 1/8" Stereo
TRIM for HF	+3 dB / -3 dB
TRIM for LF	+3 dB / -3 dB
Output Power	50W
Ac Power	AC 100-240V 50-60 Hz
Dimension (W x H x D)	150 x 226 x 180 mm (5.90 x 8.89 x 7.08 in.)
Net Weight (1 pair)	4.3 kg (151.6 oz)

## BES5

### 5" Two-way monitor speaker

Project / Home Studio / Near Field Monitoring / DAW workstation / Home Theaters

The BES series is Superlux's latest offering designed specifically for personal studios and multi-purpose audio applications, available in two options: 3.5-inch and 5-inch models.

The BES5 is a 5-inch two-way monitor system that includes one active and one passive speaker, combining high-accuracy sound quality with flexible connectivity options. Ideal for music production, video editing, and daily listening, the BES5 delivers exceptional sound detail, ensuring accurate reproduction across all frequencies. Its sleek design and durable construction make it a reliable choice for various environments.

With multiple connection options, including TRS and 1/8-inch inputs, the BES5 easily integrates with a wide range of audio devices. Additionally, it features high and low-frequency gain and attenuation controls to better adapt to different room environments and speaker placements.

- 5" Woofer and 1" Tweeter: Delivers powerful, deep bass and crisp, clear highs, ensuring a balanced sound across the entire frequency range
- 100-Watt Output Power: Perfectly suited for various audio needs, ideal for both desktop and near-field monitoring environments
- Multiple Connectivity Options: Supports TRS and 1/8" inputs, effortlessly compatible with a wide range of audio devices
- Rear Volume control: Convenient for users to quickly adjust volume, enhancing ease of use and overall experience

### Specifications

Crossover Frequency	3 KHz
Max. SPL	105 dB SPL
Frequency Response (-3 dB)	60 - 20 KHz
Impedance	10k Ω
LF	5 in.
HF	1 in. Cloth Diaphragm
Enclosure Material	Wood
Input Impedance	Bal: 1/4" TRS Unbal: RCA 1/8" Stereo
TRIM for HF	+3 dB / -3 dB
TRIM for LF	+3 dB / -3 dB
Output Power	100W
Ac Power	AC 100-240V 50-60 Hz
Dimension (W x H x D)	175 x 260 x 230 mm (6.88 x 10.23 x 9.05 in.)
Net Weight (1 pair)	6.7 kg (236.3 oz)



## BES5A

### 5" 2-Way Active Studio Monitor Speaker

Project / Home Studio / Near Field Monitoring / DAW workstation / Home Theaters

The Superlux BES5A is a very compact bi-amplified active monitor speaker. Its bass reflex system delivers outstanding monitoring precision for digital or analog production in stereo or surround formats, with performance comparable to much larger systems. Advanced driver and enclosure design are carefully matched with superior amplifier and electronic circuitry.

Bass response has been widened down to 50Hz while distortion is substantially lower. The BES5A's excellent directivity characteristics and accurate imaging together with its compact size and flexible connectivity make the BES5A the perfect monitoring tool for a wide range of applications.

- Integrated die-cast heat-sink and back panel ensures the ultimate efficient cooling
- Advanced bi-amplified power, 40W for LF and 30W for HF
- 5" cone woofer and 1" titanium dome high frequency drivers
- Frequency response 50Hz- 22kHz
- XLR balanced input and 1/4" unbalanced input.
- TRIM Control for High and Low
- Magnetic shielding

The Superlux BES Series monitors combine the best sound engineering, ID style, quality construction and superb value, making them ideal for all monitoring applications.

Engineers specializing in application, acoustics, mechanics and electronics have worked together to create this series of active monitors including the active sub-woofer to match with the main monitors.

The best value represented by these monitors is achieved through its production plan: Superlux builds these speakers with key components in our own facility including the drivers and molded enclosures.

The BES series of studio monitors incorporates the BES5A with a molded enclosure and the BES6, BES8 and BES110AS with wooden enclosures. The BES110AS is a 10" active subwoofer, offering extended bass response. The BES series models offer an exceptionally high quality and the best value for all monitoring applications.

### Specifications

Type	Bi-amp 2-way Active Speaker
Crossover Frequency	2.5 kHz, 24 dB/oct
Overall Frequency Response	50Hz - 22 kHz
Maximum Output Level	101 dB, 1m on Axis
Magnetic Shielding	Yes
Components LF/ HF	5"/ 1" titanium dome
Enclosure Type, Material	Bass-Reflex, PP
Output Power LF/ HF	40W/ 30W
Signal to Noise Ratio	>=93 dB
Input Sensitivity, VR @ center	XLR: +4 dBu, 1/4": -10 dBu
Connectors	XLR & 1/4"
Controls	Volume at the front Power ON/OFF at the front TRIM for HF: +1.5/ 0/ -1.5dB@ 15 kHz TRIM for LF: +1.5/ 0/ -1.5dB@ 60 Hz
Indicators	Green for Power and red for clipping
Power Consumption	60W
Dimension (WxHxD)	287 x 178 x 217 mm (11.3" x 7" x 8.5")
Net Weight (one speaker)	6.4 kg (14.1 lbs)
Shipping Weight (two speakers)	16 kg (35.2 lbs)



BES5A control and connecting panel



BES110A control and connecting panel

**Electronics**



## HA3D

### Compact Headphone Amplifier

#### Outdoor Recording / Home Studio

Superlux HA3D is a portable, stereo headphone amplifier designed for demanding and critical audio monitoring. This audiophile-quality headphone amp is ideal for adding headphone feeds for portable, studio, and audio enthusiast applications. The HA3D provides 3 independent headphone feeds from balanced or unbalanced line sources. Each headphone output is controlled by the associated level control, equipped with independent peak LED, and 1/4-inch output connector. With its extended bandwidth and high current/voltage drive capability the HA3D can drive headphones of various impedances to high levels with very low distortion, important for monitoring in high SPL environments. It can be powered from two-AA batteries or external DC. The HA3D will provide years of superb audio performance under the most demanding field conditions.

- 3 independent headphone outputs with individual volume controls
- Frequency response from 10 Hz to 50 kHz
- $\geq 120$  dB dynamic range
- High power driving capability, drives headphones to high levels with very low distortion
- Individual peak indicators show overload of each headphone feed
- Master Stereo / Mono switch
- Powered by 2 AA alkaline batteries or adapter with 5 – 17 V output
- Versatile input and output connectors
- Sturdy Aluminum alloy structure

#### Specifications

Frequency Response	10-50,000 Hz, $\pm 1.0$ dB, any input to any output, gain control set to 50%
Voltage Gain	Gain, Loop Out, Headphone output, Bal. Line: -3 dB, 34 dB, HP Input: -1 dB, 35 dB
Output Clipping Level	+18 dBu Minimum with 600 $\Omega$ load +16 dBu Minimum with 300 $\Omega$ load
Headphone Output impedance	200 $\Omega$
Input Clipping Level	XLR3F: +24 dBu
Dynamic Range	$\geq 120$ dB (Balanced line inputs)
THD + Noise	0.03% maximum (10-22,000 Hz @ +10 dBu input and output level, 300 $\Omega$ load, 10-22,000 Hz filter bandwidth)
Inputs	XLR3F electronically balanced, 22,000 $\Omega$ impedance 1/4" unbalanced, 9,100 $\Omega$ impedance 1/8" unbalanced, 9,100 $\Omega$ impedance, Note: only one set of inputs (balanced or unbalanced) should be connected at a time
Loop Output	Unbalanced, 200 $\Omega$ output impedance
Internal Voltage Rails	$\pm 15$ V, regulated
Power	Internal: 2 AA alkaline batteries, 12 hours life typical driving one 75 $\Omega$ headset; External: 5-17 V via threaded coaxial connector, (5.5 mm outer diameter, 2.1 mm inner diameter), pin positive, sleeve negative. Voltages above 17 VDC cause no damage to unit, but will open an internal poly fuse. Poly fuse will reset when voltage is removed.
Power LED	Green indicates power and good battery. Red indicates power with low batteries. LED turns red when approximately 4 hours of battery life remain.
Finish	Black
Dimensions	H43 x W94 x D140 mm (H1.69" x W3.7" x D5.51" in.)
Net Weight (Unit Only)	560 g (19.75 oz.)



## HA40

### 4-ch Headphone Amplifier

#### Outdoor Recording / Home Studio

Superlux HA40 is a high-grade, stereo headphone amplifier designed for demanding and critical audio monitoring. This audiophile-quality headphone amp is ideal for adding headphone feeds for studio and audio enthusiast applications.

The HA40 provides 4 independent headphone outputs. Each headphone output is controlled by the associated level control and 1/4-inch output connector. With its extended bandwidth and high current/voltage drive capability the HA40 can drive headphones of various impedances to high levels with very low distortion, important for monitoring in high SPL environments.

- 4 independent headphone outputs with individual volume controls
- High power driving capability, drives headphones to high levels with very low distortion
- Extended frequency response offers outstanding audio performance
- DC 12V adapter included

#### Specifications

Frequency response	10-50 Hz $\pm 1.0$ dB
Voltage gain	34 dB (unbalanced)
Output clipping level	+18 dB
Output impedance	200 $\Omega$
Input clipping level	+24 dB
Dynamic range	$> \pm 120$ dB
S/N ration	0.03%
Input impedance	unbal. 22k $\Omega$
Loop output impedance	200 $\Omega$
Power requirement	external power adapter, 12VDC/200mA
Power Range	100V-240VAC, depends on country
Power Indicator	red LED, located on the power switch
Dimensions	H 46 x W 200 x D 143 mm (H1.81" x W7.8" x D5.62" in.)
Net Weight	575 g (20.3 oz)



## HA4D

### Four Channel Headphone Amplifier

Podcast / Home Studio

#### HEADPHONE AMP FOR PODCAST

For podcast, there are sometimes host and guests recording together in the same room. But if there is only one headphone jack on the interface, you will need a headphone amplifier for all.

#### INTUITIVE OPERATION

HA4D is a studio-grade quality stereo headphone amplifier. It provides four independent 1/8" headphone output jack. Each headphone output is controlled by the associated level control and mute button for ultra-flexibility adjustment.

Unlike ordinary headphone amp, HA4D is powered by USB-C cable. It is very convenient because it can be powered by power port, power bank or even laptop.

- High quality circuit design.  $\geq 100$  dB dynamic range. Able to drive headphone to high levels with very low distortion
- 4 independent headphone outputs with individual volume control and mute button
- Compact and low-profile design
- Intuitive operation interface designed for Podcaster
- Powered by USB-C port

#### Specifications

Gain	24 dB
Clipping Level	+20 dBu
Output impedance	47 $\Omega$
Frequency Response	10-50K Hz +/- 1.0 dB
Dynamic Range	$\geq 100$ dB
S/N Ratio	< 0.03%
Inputs impedance	1,000 $\Omega$
Power	Type-C DC 5V
Finish	Dark gray
Dimensions	120 x 70 x 30 mm (4.72" x 2.75" x 1.18" in.)
Net Weight	233 g (8.21 oz.)



## HA1D

### Personal Monitor Amplifier

Podcast / Home Studio

In both stage performances and creative sessions within the recording studio, the ability to listen to every intricate detail of the band or music is an indispensable key factor. This crucial element directly impacts the quality and performance of musical presentations.

The Superlux HA1D has been meticulously designed to deliver an outstanding sound monitoring experience. Its lightweight and portable design, along with the thoughtful belt clip, liberates you from equipment constraints during performances. Simply connect the output of your mixing console or other devices to HA1D's XLR/1/4" dual-use input jack, insert 2xAAA batteries, and instantly monitor through HA1D's headphone output!

Equipped with a calibrated volume control, you can effortlessly adjust the sound volume to suit your personal preferences. The built-in stereo/mono source switch allows quick mode changes according to different scenarios and needs. It's all under your control, giving you complete mastery over music monitoring!

- Clear amplification of details and exceptional sound quality make it an excellent monitoring companion for stage performances or studio creations
- The compact and portable design, along with the considerate belt clip, liberates you from equipment constraints during performances
- Powered by AAA batteries, providing up to 12 hours of enduring battery life
- Equipped with a scaled volume control for easy adjustment, allowing you to achieve the optimal audio intensity according to personal preferences
- Stereo/mono source switch for on-the-fly mode changes, adapting to different scenes and requirements at any time

#### Specifications

Input	XLR-1/4" Locking COMBO Jack
Output	1/8" TRS, stereo
Impedance	0.5 $\Omega$
Max. output	2 x 100 mW@16 $\Omega$
Output Switch	Stereo / Mono output switch
Batteries	2 x AAA (not included)
Battery Life	~12 hours
Dimensions	H33 x W38 x D132 mm (H1.3" x W1.5" x D5.2" in.)
Weight	140 g (0.3 lbs)



## FMX22D

### Battery Microphone Amplifiers / Mixer

#### Field Recording / Studio

The FMX22D is a 2 channel studio grade microphone mixer designed for remote or field mixing in video, film, broadcast or professional recording applications. The compact and lightweight mixer boasts an impressive feature set starting with 2 transformer balanced XLR microphone inputs and stereo (L/R) XLR outputs. Separate stereo tape output and tape return input are provided, both feature 1/8" (3.5 mm) mini stereo jacks.

The mixer supplies +15V and +48V phantom power and a 1/4" TRS phone/headphone monitor output allows monitoring of main and tape return inputs. Both channels feature user switchable, two-stage limiting for control over signal overload and distortion. The low-cut filter removes low frequency noise caused by wind and proximity effect. Also provided is an internal test tone oscillator and slate microphone for signal calibration. The FMX22D is powered via 2 AA alkaline batteries or external DC power source.

- 2 full function microphone preamps with stereo link
- 48V or 15V phantom power supply
- 2 frequency low cut filters and adjustable limiters
- Independent gain/level control for each input and L/C/R panning controls
- Dual 7-segment peak level LED meter with 3 stage brightness control
- Built-in 1 kHz tone generator plus slate microphone for sound file identification and level matching with recorders/camcorders
- Balanced and unbalanced line level outputs for connecting with professional and prosumer recording devices
- Tape return monitor input with independent level alignments. A 3-position monitor switch with center position for normal monitoring, and left side to switch on tape return, while the right side is instant release for momentary tape return
- Powerful headphone output for professional headphone monitoring
- Operates with 2 AA batteries as well as external DC power
- Sturdy aluminum alloy case

#### Specifications

Inputs	2-XLR 3-pin female
Outputs	2-XLR 3-pin male
Monitor/Headphone Out	1/4" (6.3 mm) TRS Phone output jack
ALT I/O	Tape Out: 1/8" (3.5 mm) unbalanced output jack Tape RTN: 1/8" (3.5 mm) unbalanced input jack
Input Impedance	Transformer-balanced, 2 k $\Omega$
Output Impedance	XLR3M: 120 $\Omega$ ; Tape (3.5 mm) : 2.1 k $\Omega$
Gain	Mic In to Line Out: 66 dB Mic In to Line Out: 56 dB phantom power on Mic In to Tape Out: 56 dB Mic In to Tape Out: 46 dB phantom power on
Hum & Noise	EIN: -126 dBu minimum (150 $\Omega$ source, flat weighting, 20-20 kHz bandwidth, gain control set at 50%, phantom off)
Frequency Response	20-30 kHz
THD	0.08% max
Phantom Power	+15V & +48V
Power	2 AA alkaline batteries - 6 hours life typically (phantom off) External 5-17 VDC via coaxial connector, (5.5 mm outer diameter, 2.1 mm inner diameter), pin positive, sleeve negative. Voltages above 17 VDC cause no damage to unit, but will open an internal poly fuse. Poly fuse will reset when voltage is removed
Dimensions	H43 x W94 x D140 mm (H1.69" x W3.7" x D5.51" in.)
Net Weight	0.95 kg (2.1 lbs)

**Personal Audio**

# Headphones



## HD671

### Silicone Material Closed-back Headphone

Long Term Wearing / Cybercafe / Library / Multiple Users

This over-ear headphone with self-adjusting headband is equipped with a Ø50mm dynamic driver and closed-back structure. HD671 is simple and fashionable in design and super lightweight with a great fit. The HD671 features a low impedance and extraordinary sound quality even when connecting directly to smart phones. HD671 is the most light contact pressure closed-back headphone in the world. Equipped with soft silicone earpads, HD671 delivers optimal fit and comfort as well as superior isolation.

- Dynamic closed-back headphone
- Ø50mm precise composite diaphragm
- Lightweight design
- Studio monitoring grade, precise and balance sound
- Robust structure design

The advantage of the silicone earpads:

- The high flexibility and softness of the silicone earpads provides best-fit for the ears
- The silicone earpads significantly reduce sound leakage for the best listening experience with more powerful bass
- High durability compared to the normal earpads
- Extraordinary noise reduction for excellent ambient noise isolation
- Washable pads for easy cleaning
- The soft pads enable long term wearing
- Non-toxic design

### Specifications

Type	Dynamic, Closed-back
Driver	Ø50 mm, neodymium
Frequency Response	20-20,000 Hz
Impedance	32 Ω
Sensitivity	95 dB (1 mW)
Connector	Gold plated 3.5 mm stereo mini plug
Cable length	Ø3.5 x 2.5 m
Headphone Caliper Pressure	3.5 N
Finish	Black / White
Accessories Furnished	Soft carrying pouch, Screw-on gold-coated 3.5mm to 6.3mm stereo adapter



## HD330PRO

### Professional Semi-open Headphone

Recording Studio

HD330PRO is the circumaural, semi-open headphone which aims to attenuate ambient noise but allows the airflow generated by the vibration of the lamination to pass the well-designed grille hole on the earcup freely at the same time. It is suitable for most all kinds of the music. HD330PRO features with wide range frequency response and dynamic sound. Slightly forward sounding mids perfectly bring out the body and the emotion of vocals and instruments. Penetrating highs and bass deliver details and texture but not overstated.

HD330PRO gives you the “front row” sound image of the concert to enjoy the very rich sound while keep substantial spaces for precise soundstage between instruments. You will be pleased to be involved in the very intimate and engaging music experience of this headphone. HD330PRO is equipped with an improved headband design and softer velvet earpads to ensure wearing comfort and fit during long term use. HD330PRO is available in 32Ω and 150Ω versions to satisfy different environment needs.

- Solid bass, emotional mids, and bright, beautiful highs
- “Front row” experience for very intimate and engaging music experience
- Extraordinary wearing comfort and fit during long term use
- Features with 32Ω and 150Ω two versions to satisfy different environment needs

### Specifications

Driver	40 mm neodymium
Impedance	32 Ω & 150 Ω
Sensitivity	93 dB
Frequency Response	10 Hz-30 KHz
Cable	2.5-meter (8.2 ft.)
Connector	3.5 mm plug (Box included / 6.3 mm adapter)
Net Weight	315 g (11.11 oz)
Accessories Furnished	Soft carrying pouch, Screw-on gold-coated 3.5mm to 6.3mm stereo adapter



## HD351

### Lightweight In-Ear Headphone

#### Entertainment

Keeping it simple, the HD351 features classic black or white colour options and delivers outstanding sound quality in a lightweight in-ear headphone.

Equipped with 13.5 mm neodymium drivers, the Superlux HD351 delivers an impressive listening experience. With low distortion and a strong bass line, the HD351 brings an authentic and detailed sound experience.

Equipped with three different sizes of earplugs, the HD351 enables you to find the best fit to eliminate background noise in noisy environments so that all you have to do is pay attention to and enjoy the music.

- Equipped with high efficiency 13.5 mm neodymium drivers to bring clear sound quality
- Classic and simple design. Suitable for portable use
- Comfortable and personalized fit
- Natural, clean, and rich sound quality
- Delivered with three different sizes of earplugs

#### Specifications

Types	Dynamic, In-ear
Driver	Ø13.5 mm, Neodymium
Sensitivity	106 dB SPL (1 mW) at 1 KHz
Frequency Response	20-20,000 Hz
Max. Input Power	50 mW
Rated Impedance	16 Ω (Copper-coated aluminium wire)
Cables	1.2 meter (3.9 ft.)
Connector	Ø3.5 mm (Gold plated stereo mini plug)
Weight (with cable)	
Accessories Furnished	Ear plugs S, M, L



## HD685

### High-Definition Stereo Headphone

#### Music Appreciation

Designed to reproduce a tight bass while also featuring a sweet and clear mid-high sound profile, the HD685 is a pleasant partner for enjoying your music on the move, whether walking or sitting in a coffee shop. Its foldable structure allows for easy storage, saving your space, and the extra headphone cable includes an in-line control with microphone to allow you to easily pick up an incoming call. The HD685 is the perfect companion to enjoy your favorite music wherever you go.

- Reveals details and powerful bass for today's music
- In-line control headphone cable with microphone, made for smartphones
- Soft ear pads and headband provide comfortable fit
- Foldable design for easy storage

#### Specifications

Type	Dynamic, Closed-back
Driver	Ø40 mm, Neodymium
Sensitivity	102 dB SPL (1 mW) at 1 KHz
Frequency Response	10-20,000 Hz
Max. Input Power	200 mW
Rated Impedance	68 Ω
Earpads	Leatherette
Headphone Caliper Pressure	4.5 N
Cables	1.2-meter (3.94 ft.) cable with in-line control and mic / 1.2-meter (3.94 ft.) standard headphone cable
Connector	1/8 (3.5 mm) low profile angled, plug / 1/8 (3.5 mm) straight plug
Finish	Black
Weight (with cable)	285 g (10.05 oz)
Accessories Furnished	1.2-meter (3') straight cable, 1.2-meter remote & mic cable, Cable clip, Carrying pouch



# HD651

## Circumaural Closed-Back Headphone

### Music Appreciation / Entertainment

HD651 presents accurate and rich bass, and excellent vocal sound, perfect for both music lovers and artists. Powerful 40 mm (1.6 in.) speakers provide a superbly natural, uncoloured sound. When you are monitoring or just listening to an MP3, you can expect comfort and sonic accuracy from your HD651 headphones. HD651 comes with multicolour options and allows you to pick up your favourite one.

- Accurate and rich bass, and excellent vocal sound
- 40 mm speaker driver
- High-energy neodymium magnet
- Patented self-adjusting soft rubber headpad construction
- Multicolour available

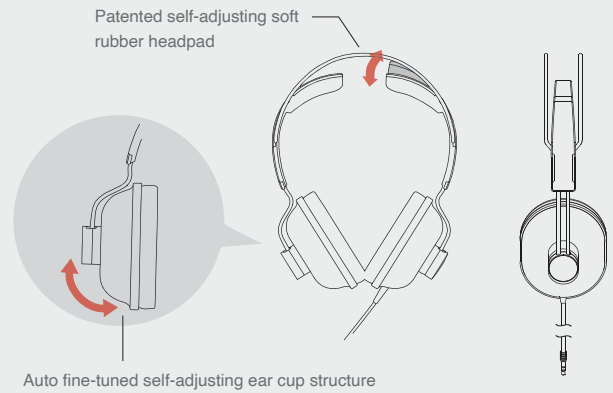

HD651 comes multicolor options

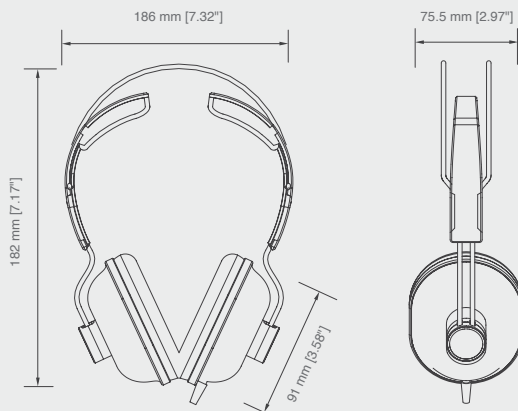

### Specifications

Types	Dynamic, Closed-back
Driver	Ø40 mm, Neodymium
Sensitivity	98 dB SPL (1 mW) at 1 KHz
Frequency Response	20-20,000 Hz
Max. Input Power	200 mW
Rated Impedance	32 Ω (Copper-coated aluminium wire)
Earpads	Leatherette
Cables	2-meter (6.6 ft.) straight cable, single-sided
Connector	Stereo mini jack 3.5 mm & 6.3 mm plug adapter
Headphone Caliper Pressure	4.5 N
Finish	Black / Gray / White / Navy Blue / Green / Purple / Red / Yellow / Baby Pink / Hot Pink
Weight (with cable)	185 g (6.5 oz)
Accessories Furnished	Carrying pouch

# HD381 Series

## In-ear Monitoring Headphone

### Music Appreciation / Entertainment / Monitoring

The HD381 series headphones feature a comfortable, personalized fit with superior noise isolation and offer 3 distinctive sound profiles, each with its own character.

The patented multi-functional cable wrapper / clip wraps the headphone cable neatly or can be clipped on clothes or necktie for added convenience. The HD381 series' high quality reproduction of the natural sound is ideally suited for personal entertainment.

- Comfortable and personalized fit
- Natural, balanced sound
- High efficiency and wide dynamic range
- Patented dual function cable wrapper / clip included

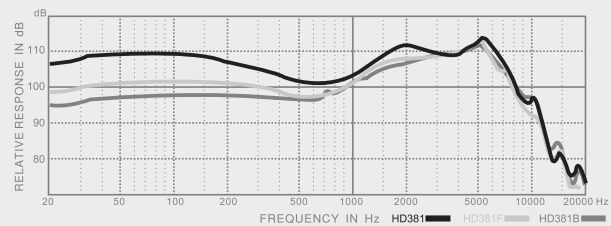

\*FR charts shown above are test results determined by China Standard IEC318 ear simulation.



#### HD381

Rich bass and powerful low end, "On stage" sound, perfect for enjoying that booming bass sound. HD381 presents a pronounced bass presence and will surprise you with its powerful low end performance.



#### HD381F

Flat frequency response, "Front row" sound image, great for most kinds of music and capturing those sweet vocal sounds. The HD381F features a flat response, suitable for most kinds of music, and delivers a sweet vocal sound, as if the singer was standing right in front of you.



#### HD381B

Crystal clear sound, deep and tight bass, "In hall" feel. HD381B the best choice for personal entertainment as well as professional in-ear monitoring applications.

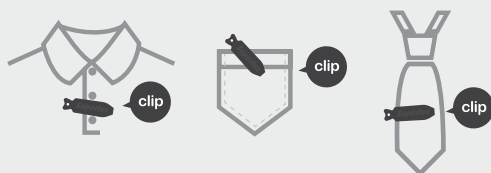

Patented multi-function cable wrapped clip

### Specifications

Types	Dynamic, In-ear
Driver	Ø13.5 mm, Neodymium
Sensitivity	103 dB SPL (1 mW) at 1 KHz
Frequency Response	20-20,000 Hz
Max. Input Power	50 mW
Rated Impedance	16 Ω (Copper-coated aluminium wire)
Cables	0.6-meter (1.9 ft.)
Connector	Gold plated stereo mini plug
Weight (with cable)	12 g (0.42 oz)
Finish	HD381 Black / HD381F White / HD381B Grey
Accessories Furnished	Cable wrapper, Ear adapters S, M, L, 0.6 m extension cable



## HD440

### Booming Bass Headphone

#### Entertainment / Games

The HD440 features a booming bass and crystal-clear high frequency. It's great for most kinds of music and exceptional for computer gaming. The included self-adjusting headband and optimized headband pressure offer a truly comfortable fit for long term use. The included sturdy plastic storage box ensures secure protection during transportation.

- Booming bass headphones, great for most kinds of music
- Self-adjusting headband for optimum fit
- High noise attenuation for optimum ambient-noise control

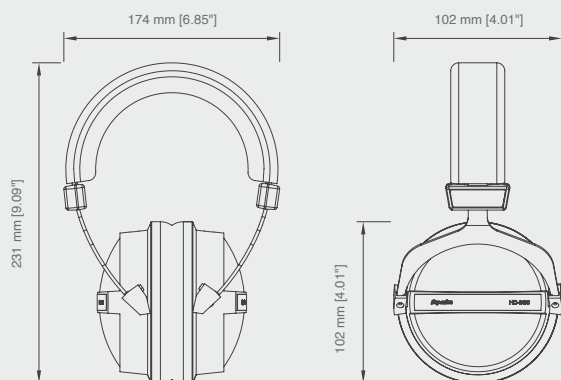

#### Specifications

Type	Dynamic, Closed-back
Driver	Ø40 mm, Neodymium
Sensitivity	96 dB SPL (1 mW) at 1 KHz
Frequency Response	20-20,000 Hz
Max. Input Power	100 mW
Rated Impedance	150 Ω (Copper-coated aluminium wire)
Earpads	Leatherette
Cables	2.5-meter (8.2 ft.) straight, single-sided cable
Connector	Gold plated stereo mini plug
Headphone Caliper Pressure	4 N
Finish	Black
Weight (with cable)	300 g (10.6 oz)
Accessories Furnished	1/4" (6.3 mm) adapter, Carrying pouch

# Microphones



## D421

### Dynamic Broadcast Microphone

Studio Recording / Broadcast / Vocals

D421 is a broadcast dynamic microphone with flat and wide frequency response and low proximity effect. The natural and clear sound is suitable in broadcasting, vocal and studio application.

The special-designed anti-electromagnetic can effectively isolate the electromagnetic interference generated by the computer and the screen. It can also reduce the mechanical noise.

- Flat and wide frequency response, suitable for podcasting, recording
- Special design structure, reduce the mechanical noise effectively
- Built-in two filters: low cut and mid-high boost
- The cardioid capsule can reduce the surrounding environment noise effectively
- The anti-electromagnetic design can isolate the computer from the electromagnetic interference
- Robust microphone body

### Specifications

Polar Pattern	Cardioid
Frequency Response	50-20,000 Hz
Sensitivity	-59 dBV / Pa (1.12 mV)
Output Impedance	150 Ω
Electromagnetic Hum Sensitivity (Typical, Equivalent SPL/milliOersted)	60 Hz: 11 dB, 500 Hz: 24 dB, 1 kHz: 33 dB
Connector	XLR
Dimensions	Ø62.12 x 204.5 mm (Ø2.44" x 8.05")
Net Weight	606 g (21.37 oz)
Accessories Furnished	Pouch, YA2 threaded adapter, HM85 pivoting stand mount
Optional Accessories	HM26A Shock Mount
Packaging	Colorful outer packaging

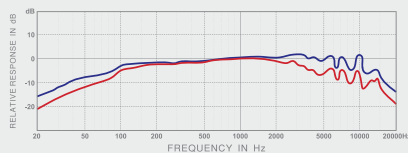

## WO518

### Miniature Omni Condenser Lavalier Microphone

TV Broadcasting / Speech / Cello / Double Bass / Eastern Strings

The WO518 is an omni lavalier clip-on condenser microphone with a frequency response tailored to give accurate, intelligible speech recognition. It is ideally suited for the interview programs of TV broadcasting and video production. The extended bass frequency range of this mic makes it the best choice for cello and double bass sound pick-up.

- Boosted wire mesh grille increases the HF response
- Wind screen foam to reduce those unwanted "pop" sounds
- Flat and wide frequency response, high SPL, high dynamic range, low distortion
- WO518TQG is for wireless systems

WO518TQG TA4F connector for wireless system

WO518XLR TA3F connector for PS418S preamp (phantom power only)

WO518DXLR TA3F connector for PS418D preamp (either phantom power or battery)

### Specifications

Model No.	WO518TQG	WO518XLR	WO518DXLR
Element	Back electret, Ø6 mm (Ø0.24")		
Polar Pattern	Omni		
Frequency response	20-20,000 Hz		
Low Frequency Filter	N/A	N/A	80Hz@12 dB / oct / (PS418D)
Sensitivity	-32 dBV/Pa (25.1 mV)	-44 dBV/Pa (6.3 mV)	Phantom: -40 dBV/Pa (10 mV) Battery: -43 dBV/Pa (7.1 mV)
Output Impedance	200 Ω	200 Ω	Phantom: 200 Ω Battery: 600 Ω
Min. Load Impedance	1,000 Ω	1,000 Ω	Phantom: 1,000 Ω Battery: 2,000 Ω
S/N Ratio	N/A	72 dB	Phantom: 76 dB Battery: 75 dB
Equivalent Output Noise	N/A	22 dB	Phantom: 18 dB Battery: 19 dB
Max. SPL	N/A	132 dB SPL	Phantom: 130 dB SPL Battery: 126 dB SPL
Dynamic Range	N/A	110 dB	Phantom: 112 dB Battery: 107 dB
Power Requirements	1.5-9V DC	12-52V DC, 3.5 mA	Phantom: 12-52V DC, 3.5 mA Battery: 1.5VDC AA/UM3
Finish	Black		
Connector	TA4F, 1.5-meter cable		
Dimensions	Microphone: Ø8 x 12 mm (Ø0.31" x 0.47" in.) WO518XLR PS418S: Ø21 x 106 mm (Ø0.83" x 4.18" in.) WO518DXLR PS418D: H84 x W63 x D22.5 mm (H3.3" x W2.48" x D0.89" in.)		
Net Weight	Microphone: 20 g (0.7 oz) WO518XLR PS418S: 118 g (4.2 oz) WO518DXLR PS418D: 245 g (8.6 oz)		
Accessories Furnished	S12 HF boost windscreen, S13 windscreen, clip WO518XLR PS418S preamp WO518DXLR 1.5V AA alkaline battery, PS418D preamp		
Packaging	Colorful outer packaging		

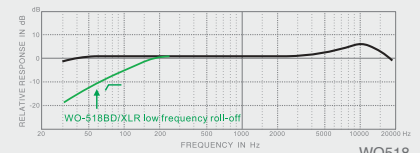
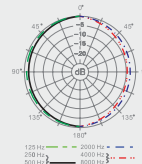



# D108MKII

## Dynamic Podcast Microphone

Studio / Live Recording / Vocal

Returning to our roots, Superlux embarks on a new journey in fundamental microphone research. The first-generation Superlux D108, known for its consistent directional characteristics, has effectively addressed live sound amplification challenges for many professionals. In the upgraded version, D108MKII, we strive for a higher level, integrating over three decades of Superlux's profound understanding of microphones. Carefully designed frequency response curves faithfully reproduce the natural tones of the human voice. Its consistent directionality not only enhances the microphone's penetration but also significantly increases gain before feedback. Furthermore, handheld noise has always been a concern for many microphone users. In the D108MKII, Superlux, through a deep understanding of low-frequency curves and directional characteristics, coupled with continuous practical experience, has developed a new type of shock mount, significantly reducing handling noise. Every word spoken and every song sung is exceedingly complex. However, it is this very complexity that allows us to convey our emotions and individuality fully. It is nature's most beautiful gift to us, enriching human interaction. The D108MKII diaphragm possesses outstanding transient response and high SPL, ensuring rapid and distortion-free reaction to sound source pressure, showcasing a high level of vocal detail reproduction. Superlux has always been committed to enhancing product technology and quality. The upgrade and redesign of the D108MKII not only astonish professionals but also provide live users with professional-grade recording quality. Let us look forward to D108MKII enhancing your musical journey, delivering a superior musical experience.

- The consistent directionality not only enhances the microphone's penetration but also significantly increases the gain before feedback
- Carefully designed frequency response faithfully reproduces the natural tones of the human voice
- The new shock mount design significantly reduces handling noise
- Outstanding transient response and high SPL of the diaphragm ensure rapid and distortion-free reaction to sound source pressure after receiving the sound source pressure

The D108MKII model is the D108SMKII with an ON / OFF switch.



D108MKII Dynamic Podcast Microphone Kit

### Specifications

Type	Dynamic
Polar Pattern	Supercardioid
Frequency Response	50-18,000 Hz
Sensitivity	-54 dBV/Pa (2 mV)
Output Impedance	200 Ω
Max. SPL	150 dB SPL
Finish	Black
Connector	XLR3M
Dimensions	Ø50 x 182 mm (Ø1.96" x 7.16")
Net Weight	430 g (15.16 oz)
Kit Net Weight	3.54 kg (124.9 oz)

D108MKII / D108SMKII Single package:  
 HM38S Microphone Clip  
 D108MKII Kit-package:  
 Accessories Furnished A5 Carrying Case, HM26B Universal Shockmount, D2 Zinc-alloy Diecast Table Stand, HM38S Microphone Clip, CFM2.5FRM 2.5-meter XLR Cable (right-angle female connector)

Packaging Colorful outer packaging



D108MKII  
Section View

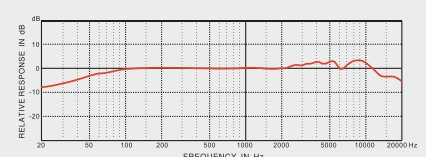
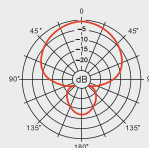

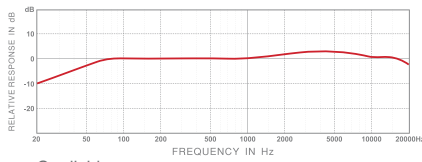

Cardioid

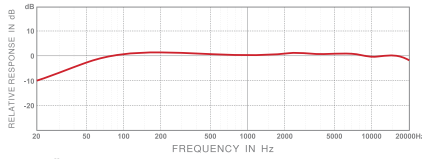

8-figure



## E431U

### Multi-Pattern condenser USB Microphone

#### Home Recording / Studio Recording / Instruments

E431U is equipped with dual Ø14mm back-electret capsules which deliver crisp and dynamic sound reproduction. It features three different pattern settings which makes it easy to select the best pickup pattern for different professional recording requirements. E431U features a 3.5 mm standard headphone jack for real-time and zero-latency monitoring. It is also possible to adjust the microphone gain through the knobs at the front of the microphone. It is unnecessary to operate the microphone via complicated driver. All you need is to plug the USB cable into the USB socket of a computer and to follow some simple system operation to start recording.

- USB digital recording condenser microphone, multi-pattern function to offer the best pickup pattern under different recording requirements
- 24 bit, 192 kHz sampling rate, equipped with high quality A / D converter for excellent sound quality
- Featured with headphone jack and individual volume control for zero-latency monitoring, the built-in headphone amplifier ensures extremely clear and rich playback details even at high volume
- Flat and wide frequency response perfect for podcasting, home studio, live recording and narrating
- Plug-and-play, compatible with Windows and Mac OS.

#### Specifications

Type	Back electret capsules, 2 x Ø14 mm (Ø0.55")
Polar Pattern	Cardioid / 8-figure / Omni
Frequency Response	20-20,000 Hz
Sensitivity	-38 dBV/Pa (12.6 mV)
Output Impedance	> 16 Ω
Max. SPL	108 dB (THD < 1% at 1 kHz)
Power Requirements	USB (5 V DC)
Bit Depth	24 bit
Sampling Rate	192 kHz
Volume Control	Direct monitoring volume control, headphone monitoring volume control
Output Jack	USB C-Type
Headphone output power	150 mW (at 1 kHz, 1% T.H.D., 16 Ω)
T.H.D.	< 0.5 % (at 1 kHz)
Headphone output jack	Ø3.5 mm stereo mini jack
Finish	Black
Dimensions	230 x 90 x 55 mm (9" x 3.5" x 2.2")
Net Weight	509 g (17.9 oz)
Accessories Furnished	1.5-meter type-C USB cable, Die-cast table stand
Optional Accessories	HM61 Elastic suspension shock mount
Packaging	Hand carrying bag, colorful outer packaging

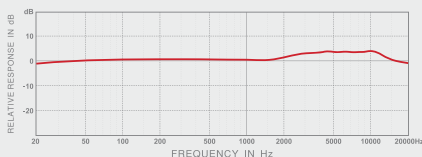

Omni

## L401U

### 1" Large Diaphragm USB Microphone

#### Home Recording / Studio Recording / Instruments

It is equipped with a 1", 3µm ultra-thin gold-plated diaphragm capsule to ensure studio-grade recording quality in any stage, home or studio environment. The plug-and-play design of the L401U large diaphragm USB microphone ensures compatibility with both Windows and Mac operating systems and supports the majority of available DAW software. The high-quality A to D converter and USB output of the L401U makes accurate recording effortless. L401U features a zero-latency stereo headphone monitoring (3.5mm) jack to provide real-time microphone input monitoring. A direct/mixing knob allows you to adjust the monitoring level between mic input and audio output easily. The L401U large diaphragm microphone is a quality tool that is the right choice for any professional stage, home or studio application.

- USB digital recording condenser microphone, plug-and-play, compatible with Windows and Mac OS system and supports most of the DAW software
- Ø1", 3 µm ultra-thin gold-plated diaphragm capsule of L401U captures exquisite and warm sound, the cardioid pickup pattern of L401U is very suitable for vocal recording, acoustic instruments and any other sources
- The built-in headphone amplifier ensures extremely clear and rich playback details even under high volume, direct monitoring provides zero-latency monitoring, built-in high quality AD converter, and with 24 bit, 192 kHz sampling rate

#### Specifications

Type	True condenser, Ø1" (Ø25.4 mm)
Polar Pattern	Cardioid
Frequency Response	20-20,000 Hz
Sensitivity	-34 dBV/Pa (20 mV/Pa)
Impedance	> 16 Ω
Max. SPL	110 dB (THD < 1 %, at 1 kHz)
Power Requirements	Powered by USB (5 V DC)
Bit Depth	24 bit
Sampling Rate	24 bit / 192 kHz
Volume Control	Direct / mixing monitoring volume control, headphone monitoring volume control
Output Jack	USB connector
Headphone output power	150 mW (at 1 kHz, 1% T.H.D., 16 Ω)
T.H.D.	< 0.5 % (at 1 kHz)
Headphone output jack	Ø3.5 mm stereo mini jack
Finish	Black
Dimensions	Ø105 x 254.8 mm (Ø4.13" x 10.03")
Net Weight	1200 g (42.3 oz)
Accessories Furnished	3M Type-B USB cable, Die-cast table stand, Foam windscreens
Optional Accessories	HM60 Elastic suspension shock mount
Packaging	Hand carrying bag, colorful outer packaging

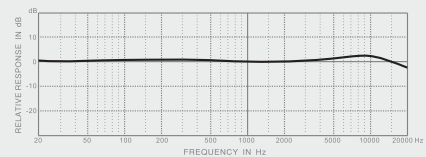



## E205U

### USB Condenser Microphone

Home Recording / Studio Recording / Instruments

The E205U is a high-quality condenser microphone with an advanced A/D and USB interface which gives you digital recording capabilities instantly with no external digital interface or software driver required. It is USB compatible with Mac, Windows, and most DAW software programmes, including GarageBand. The E205U offers premium quality audio recording with ease and mobility, and with its mic stand mount adapter and 9.8 ft. (3-meter) USB cable, the E205U is a valuable kit for any project studio.

- Smooth, flat frequency response
- Plug in and start recording, no drivers required
- Up to 16 bit / 48 kHz sampling rate
- Powered by USB power, no external power required
- Headphone output and volume control

### Specifications

Type	Back electret
Polar Pattern	Supercardioid
Frequency Response	30 - 18,000 Hz
Sensitivity	-38 dBV/Pa (12.6 mV) (@1,000 Hz Open Circuit Voltage)
Max. SPL	>135 dB
Power Requirements	USB 5 V $\equiv$ , < 30 mA
Resolution	Up to 16 bit/48k Hz sampling rate
Finish	Champagne silver
Connector	USB B-Type, 1/8" (3.5 mm) phone connector
Dimensions	Ø54 x 150 mm (Ø2.13" x 5.9")
Net Weight	422 g (14.9 oz)
Accessories Furnished	YA2 threaded adapter, HM85 pivoting stand mount, Pouch, 3M USB cable, Table tripod DS01
Packaging	Colorful outer packaging

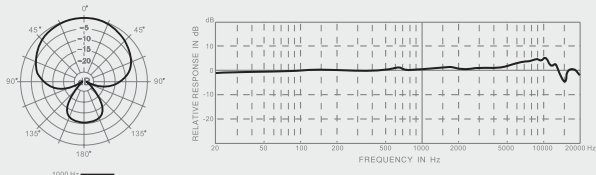

## E205UMKII

### USB Condenser Microphone

Home Recording / Studio Recording / Instruments

E205UMKII is the upgraded version of USB condenser microphone E205U, which is specialized in delivering high resolution audio and flat and wide frequency response. E205UMKII can be operated with Windows and Mac OS systems. It is very suitable for Podcasting and personal recording.

The equipped headphone socket and the headphone volume gain control make real-time monitoring easier and better!

- Delivering the high resolution audio with up to 24 bit / 96 kHz sampling rate
- Smooth and flat frequency response perfect for podcasting and home studio recording
- Compatible with Windows and Mac OS system
- Equipped with headphone output jack and gain control for easy and perfect real-time monitoring

### Specifications

Type	Back Electret Condenser
Polar Pattern	Supercardioid
Frequency Response	20 - 20,000 Hz
Sensitivity	-35 dBV / Pa (12.6 mV) (@1,000 Hz)
Max. SPL	>135 dB
Power Requirements	USB 5V
Resolution	Up to 24 bit / 96 kHz sampling rate
Finish	Black, White, Rose gold
Connector	USB B-TYPE, 1/8" (3.5 mm) mini jack
Dimensions	Ø54 x 150 mm (Ø2.13" x 5.9")
Net Weight	422 g (14.9 oz)
Accessories Furnished	YA2 threaded adapter, HM85 pivoting stand mount, Pouch, 3-meter cable, DS01 Table stand
Packaging	Colorful outer packaging

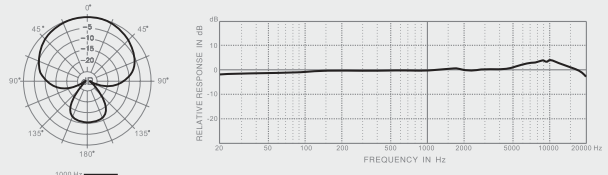



## E531B

### M/S Stereo Field Recording Microphone

Flash Recording / Camcorder / Concert Logging

E531B is configured with M/S stereo arrangement for excellent characteristics and natural sound space. Effective coverage angle can be switched. 90° is for narrower sound source such as solo instrument or dialogue for clear positioning with stereo sound space. 120° is for wider sound sources such as orchestra, choir, and stage performance for natural stereo recording. E531B is very suitable for digital recording devices, such as flash recorders, to record concerts, meetings, and music shows.

- M/S stereo spaces, for natural and clear stereo sound image
- Coverage can be switched between 90° and 120°
- Light weight body with professional clip, convenient for carrying and set-up

#### Specifications



Type	Back electret, Ø9.7 mm (Ø0.39")
Polar pattern	Cardioid + figure 8
Frequency response	100-15,000 Hz
Sensitivity	-45 dBV / Pa (5.6 mV)
Output Impedance	1,000 Ω
Min. Load Impedance	2,000 Ω
Equivalent Output Noise	25 dB
Max. SPL	110 dB
S/N ratio	69 dB
Dynamic range	85 dB
Power Requirements	1.5 V AA / UM3 battery, 4 mA
Battery lifetime	approx. 200 hours
Connector	3.5 mm (1/8") stereo mini plug, 1.5-meter cable
Dimensions	29 × 126.5 × 29 mm (1.14" × 4.98" × 1.14" in.)
Weight (with battery)	110 g (3.9 oz.)

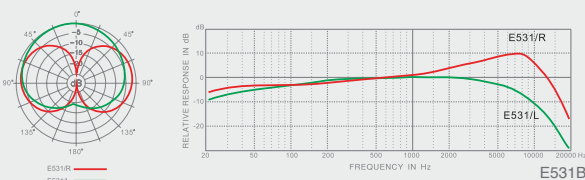

## E532B

### XY Stereo Microphone

Flash Recording / Camcorder / Concert Logging

The E532B with stereo XY setup capsules arrangement makes it easy to record in stereo and get a realistic, spacious capture at a live event. Working very well with a camcorder or a flash recorder, the E532B has an integrated 1.5-meter cable with a 1/8" mini stereo plug and allows placement of the microphone closer to performers to increase recording quality. The switchable low cut filter will reduce wind noise and stage rumbling. It is powered by one AA alkaline battery that can last for hundreds of hours of use.

- Matched pair, XY arrangement capsules
- Designed for popular camcorders and palm size flash recorders
- Switchable low cut filter to reduce wind noise and stage rumble
- Powered by one AA battery and has a built-in low power indicator

#### Specifications



Type	Back electret, Ø9.7 mm (Ø0.39")
Polar Pattern	Cardioid + Cardioid
Frequency Response	40-18,000 Hz
Low Frequency Filter	80 Hz, 12 dB/oct, internal
Sensitivity	-40 dBV/Pa (10 mV)
Output Impedance	1,000 Ω
Min. Load Impedance	2,000 Ω
S/N Ratio	69 dB
Equivalent Output Noise	25 dB
Max. SPL	110 dB SPL
Dynamic Range	85 dB
Power Requirements	1.5V AA/UM3 battery, 4 mA
Finish	Black
Connector	3.5 mm (1/8") stereo mini plug, 1.5-meter cable
Dimensions	29 × 131 × 29 mm (1.14" × 5.16" × 1.14" in.)
Net Weight	110g (3.9 oz)
Packaging	Colorful outer packaging

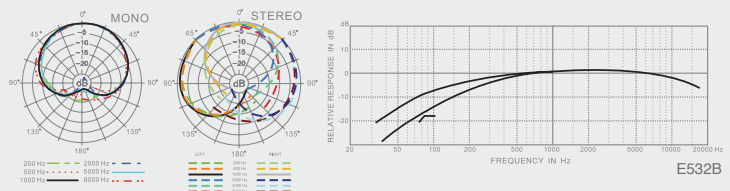



## E522B

### XY Stereo Microphone

Broadcast / TV / Amateur Recording / Flash Recording

The E522B with stereo XY setup capsules arrangement makes it easy to record in stereo and get a realistic, spacious capture at a live event. Working very well with a camcorder or a flash recorder, the microphone comes with a cable with 1/8" mini stereo plug allowing users to place the microphone closer to performers to increase recording quality. Its switchable low cut filter will reduce wind noise and stage rumbling. It is powered by one AA alkaline battery that can last for hundreds of hours of use.

- Matched pair, XY arrangement capsules
- ON/OFF switch with locking plate
- Internal low cut switch for reducing wind noise and stage rumbling
- Stereo unbalanced output
- Powered by an AA battery and built-in low power indicator

#### Specifications



Type	Back electret, Ø9.7 mm (Ø0.39")
Polar Pattern	Cardioid + Cardioid
Frequency Response	30-20,000 Hz
Low Frequency Filter	Low Frequency Filter
Sensitivity	-47 dBV/Pa ( 44 mV )
Output Impedance	200 Ω
Min. Load Impedance	1,000 Ω
S/N Ratio	70 dB
Equivalent Output Noise	24 dB
Max. SPL	126 dB SPL
Dynamic Range	102 dB
Power Requirements	1.5V AA/UM3 battery, 4 mA
Finish	Black
Connector	XLR3M
Dimensions	Grille net : 64 × 38 mm, Ø23.5 × 218 mm (2.52" × 1.5", Ø0.93" × 8.59" in.)
Net Weight	310 g (10.9 oz)
Packaging	Colorful outer packaging



Table stand is optional

## D106

### Net Meeting Dynamic Microphone

Students / Net Meeting

The D106 is a very affordable cardioid microphone for net meetings and general applications. Accompanied by a 3.5 mm plug and 3.5 mm to 6.3 mm adapter, the D106 is also a convenient choice for the Superlux MA818 portable mini-PA.

- Tailored response for reproducing clear vocal sound
- Cardioid directivity for high gain before feedback
- ON/OFF switch
- A convenient choice for MA818
- Includes 3.5mm to 6.3 mm (1/8" to 1/4") adapter

#### Specifications



Type	Dynamic
Polar Pattern	Cardioid
Frequency Response	70-12,000 Hz
Sensitivity	-53 dBV/Pa (2.2 mV)
Output Impedance	500 Ω
Min. Load Impedance	500 Ω
Max. SPL	135 dB SPL
Finish	Black
Connector	3.5 mm (1/8") mono plug, 3-meter cable
Dimensions	Ø54 × 208 mm (Ø2.13" × 8.19" in.)
Net Weight	265 g (9.3 oz)
Packaging	White box

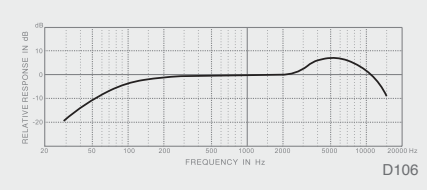
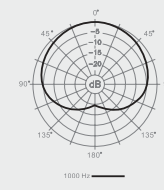
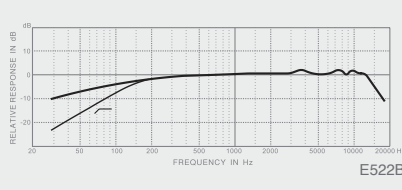
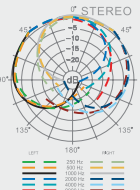
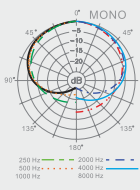



## D10A

### Dynamic Microphone

#### General Purpose / Net Meeting

The D10A is a light weight omnidirectional microphone with a comfortable feel without handling noise or the proximity effect. Features such as an integrated belt clip and 1.5-meter cable with anti-tensile structure make the D10A a perfect microphone for home recordings, small meetings, nets meeting, as well as general PA applications. The D10A is a convenient choice for use with the Superlux MA818 portable mini-PA and MA500 personal voice enhancer.

- 1/8" (3.5 mm) mini plug, suitable for computer-type audio input
- Omnidirectional directivity without handling noise or proximity effect
- Belt clip for easy storage when not in use
- Optional DS106 table stand for use in net meetings
- A good match for the MA500 personal voice enhancer and also works well with the MA818 portable mini-PA
- 1.5-meter cable with 3.5 mm stereo mini plug, wired as mono

#### Specifications



Type	Dynamic
Polar Pattern	Omni
Frequency Response	85-12,500 Hz
Sensitivity	-55 dBV/Pa (1.8 mV)
Output Impedance	200 Ω
Min. Load Impedance	200 Ω
Max. SPL	135 dB
Finish	Black
Connector	3.5 mm (1/8") stereo mini plug, 1.5-meter cable
Dimensions	Ø36 × 137 mm (Ø1.42" × 5.4")
Net Weight	95 g (3.4 oz)

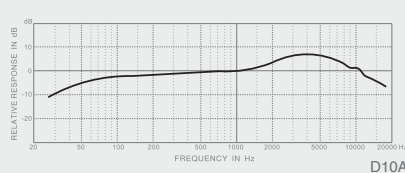
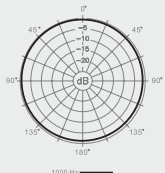

D10A



## EM210

### Miniature Microphone

#### Teacher / Mobile Retail Stands / Compact PA System

Accompanied by a PS210 battery power adapter, a 3-meter cable, and a tie clip, the EM210 is a miniature omnidirectional microphone. The EM210 is a convenient choice for the Superlux MA500 personal voice enhancer and MA818 portable mini-PA. When used with the MA500 or MA818, the integrated cable is only 1.5 meters long.

- Miniature lavalier microphone with tip clip
- Powered by one AA 1.5V battery
- Provides clear vocal sound
- Includes windscreen for reducing wind noise
- Integrated 3-meter cable with mini plug
- A good choice for the MA500 personal voice enhancer and the MA818 portable mini-PA

#### Specifications



Type	Back electret, Ø9.7 mm (Ø0.39")
Polar Pattern	Omni
Frequency Response	30-18,000 Hz
Sensitivity	-46 dBV/Pa (5 mV)
Output Impedance	100 Ω
Min. Load Impedance	2,000 Ω
Max. SPL	110 dB
Power Requirements	1.5V-6V DC
Finish	Black
Connector	3.5 mm (1/8") mono plug, 3-meter cable
Dimensions	Ø13.5 × 20.5 mm (Ø0.53" × 0.81" in.)
Net Weight	25 g (0.9 oz)
Packaging	Colorful outer packaging

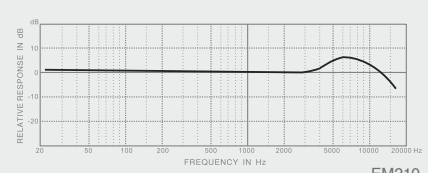
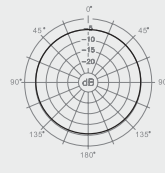

EM210



# E105

## Headworn Cardioid Microphone

### Sports / Interview / Drama

The E105 is a condenser headworn miniature microphone designed for close-up applications and always keeps the same distance between the mic and the sound source. Its cardioid directivity ensures high gain before feedback.

The improved cable arrangement, flexible headband, and hidden comfortable outline make it perfect for wearing a long-time. It is suitable for sports, the gym, interviews, dramas, speech, and small PAs. The E105 is a convenient choice for the MA500 personal voice enhancer and the MA818 personal mini-PA.

- 1/8" (3.5 mm) stereo mini plug
- Strong and flexible gooseneck make it easy to position the capsule in the sweet spot

- Flexible steel headband for comfortable use
- Includes windscreen for cutting down popping noise
- A convenient choice for MA818
- A convenient choice for the MA500 personal voice enhancer and the MA818 portable mini-PA

E105	1/8" (3.5 mm) stereo mini plug
E105TQG	TA4F connector, for working with wireless body pack transmitters
E105XLR	TA3F connector, includes PS418S preamp (powered by phantom)
E105DXLR	TA3F connector, includes PS418D preamp (powered by battery or phantom)

### Specifications



Model NO.	E105	E105TQG	E105XLR	E105DXLR
Type	Back electret, Ø6 mm (Ø0.24")	Back electret, Ø6 mm (Ø0.24")	Back electret, Ø6 mm (Ø0.24")	Back electret, Ø6 mm (Ø0.24")
Polar Pattern	Cardioid	Cardioid	Cardioid	Cardioid
Frequency Response	80-18,000 Hz	80-18,000 Hz	80-18,000 Hz	80-18,000 Hz
Low Frequency Filter	NA	NA	NA	80 Hz, 12 dB/oct (@PS418D)
Sensitivity	-46 dBV/Pa (5 mV)	-35 dBV/Pa (17.8 mV)	Phantom: -46 dBV/Pa (5 mV)	Phantom: -46 dBV/Pa (5 mV), Battery: -50 dBV/Pa (3.2 mV)
Output Impedance	200 Ω	200 Ω	Phantom: 200 Ω	Phantom: 200 Ω, Battery: 600 Ω
Min. Load Impedance	1,000 Ω	1,000 Ω	Phantom: 1,000 Ω	Phantom: 1,000 Ω, Battery: 2,000 Ω
S/N Ratio	NA	NA	71 dB	71 dB
Equivalent Output Noise	NA	NA	23 dB	23 dB
Max. SPL	NA	NA	139 dB SPL	Phantom: 139 dB SPL, Battery: 129 dB SPL
Dynamic Range	NA	NA	116 dB	Phantom: 116 dB, Battery: 105 dB
Power Requirements	1.5-9V DC	1.5-9V DC	Phantom: 12-52V DC, 3.5 mA	Phantom: 12-52V DC, 3.5 mA, Battery: 1.5V AA/UM3 alkaline battery
Finish	Black	Black	Black	Black
Connector	3.5 mm stereo mini plug, 1.5-meter cable	TA4F, 1.5-meter cable	TA3F, 1.5-meter cable	TA3F, 1.5-meter cable
Dimensions	Width: 166 mm (6.5") Gooseneck: 100 mm (3.94") Microphone: Ø8.2 mm (Ø0.32")	Width: 166 mm (6.5") Gooseneck: 100 mm (3.94") Microphone: Ø8.2 mm (Ø0.32")	Width: 166 mm (6.5") Gooseneck: 100 mm (3.94") Microphone: Ø8.2 mm (Ø0.32") PS418S: Ø21 × 106 mm (Ø0.83" × 4.18")	Width: 166 mm (6.5") Gooseneck: 100 mm (3.94") Microphone: Ø8.2 mm (Ø0.32") PS418D: H84 × W63 × D22.5 mm (H3.3" × W2.48" × D0.89")
Net Weight	Microphone: 30 g (1.05 oz)	Microphone: 30 g (1.05 oz)	Microphone: 30 g (1.05 oz), PS418S: 118 g (4.2 oz)	Microphone: 30 g (1.05 oz), PS418D: 245 g (8.6 oz)
Furnished Accessories	S23 windscreen	S23 windscreen	S23 windscreen, PS418S preamplifier	S23 windscreen, PS418D preamplifier (phantom or battery), 1.5V AA alkaline battery
Packaging	White box	White box	White box	White box

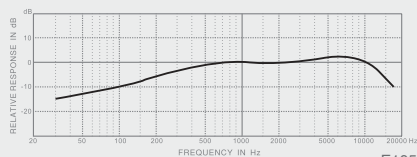
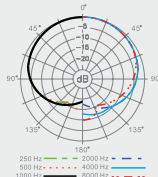



# E108

## Headworn Cardioid Microphone

### Sports / Interview / Drama

The E108 is a miniature headworn condenser microphone that is designed for close-up applications and always keeps the same distance between the mic and the sound source. Its figure-8 directivity ensures satisfactory operation in a noisy environment and has high gain before feedback.

The improved cable arrangement, flexible headband, and hidden comfortable outline make it perfect for long-time use. It is suitable for sports, the gym, interviews, dramas, speeches, and small PAs. The E108 is a convenient choice for the MA500 personal voice enhancer and the MA818 personal mini-PA.

- Good surrounding sound rejection
- Strong and flexible gooseneck make it easy to position the capsule in the sweet spot

- Flexible steel headband offering comfortable wearing
- Included windscreen for cutting down pop noise
- 1/8" (3.5 mm) stereo mini plug, wired as mono
- A convenient choice for MA500 personal voice enhancer and MA818 portable mini-PA

E108	1/8" (3.5 mm) stereo mini plug
E108TQG	TA4F connector, for working with a wireless body-pack transmitter
E108XLR	TA3F connector, including the PS418S preamp (powered by phantom)
E108DXLR	TA3F connector, including the PS418D preamp (powered by battery or phantom)

### Specifications

Model No.	E108	E108TQG	E108XLR	E108DXLR
Type	Back electret, Ø6 mm (Ø0.24")	Back electret, Ø6 mm (Ø0.24")	Back electret, Ø6 mm (Ø0.24")	Back electret, Ø6 mm (Ø0.24")
Polar Pattern	Figure 8	Figure 8	Figure 8	Figure 8
Frequency Response	80-18,000 Hz	80-18,000 Hz	80-18,000 Hz	80-18,000 Hz
Low Frequency Filter	NA	NA	NA	80 Hz, 12 dB/oct (@PS418D)
Sensitivity	46 dBV/Pa (5 mV)	-33 dBV/Pa (22.4 mV)	Phantom: -46 dBV/Pa (5 mV)	Phantom: -46 dBV/Pa (5 mV), Battery: -50 dBV/Pa (3.2 mV)
Output Impedance	200 Ω	200 Ω	Phantom: 200 Ω	Phantom: 200 Ω, Battery: 600 Ω
Min. Load Impedance	1,000 Ω	1,000 Ω	Phantom: 1,000 Ω	Phantom: 1,000 Ω, Battery: 2,000 Ω
S/N Ratio	NA	NA	71 dB	71 dB
Equivalent Output Noise	NA	NA	23 dB	23 dB
Max. SPL	NA	NA	137 dB SPL	Phantom: 137 dB SPL, Battery: 127 dB SPL
Dynamic Range	NA	NA	114 dB	Phantom: 114 dB, Battery: 104 dB
Power Requirements	1.5-9V DC	1.5-9V DC	Phantom: 12-52V DC, 3.5 mA	Phantom: 12-52V DC, 3.5 mA, Battery: 1.5V AA/UM3
Finish	Black	Black	Black	Black
Connector	3.5 mm stereo mini plug, 1.5-meter cable	TA4F, 1.5-meter cable	TA3F, 1.5-meter cable	TA3F, 1.5-meter cable
Dimensions	Width: 166 mm (6.5") Gooseneck: 100 mm (3.94") Microphone: Ø8.2 mm (Ø0.32")	Width: 166 mm (6.5") Gooseneck: 100 mm (3.94") Microphone: Ø8.2 mm (Ø0.32")	Width: 166 mm (6.5") Gooseneck: 100 mm (3.94") Microphone: Ø 8.2 mm (Ø 0.32") PS418S: Ø21 × 106 mm (Ø0.83" × 4.18")	Width: 166 mm (6.5") Gooseneck: 100 mm (3.94") Microphone: Ø8.2 mm (Ø0.32") PS418D: H84 × W63 × D22.5 mm (H3.3" × W2.48" × D0.89")
Net Weight	Microphone: 30 g (1.05 oz)	Microphone: 30 g (1.05 oz)	Microphone: 30 g (1.05 oz) PS418S: 118 g (4.2 oz)	Microphone: 30 g (1.05 oz) PS418D: 245 g (8.6 oz)
Furnished Accessories	S23 windscreen	S23 windscreen	S23 windscreen, PS418S preamplifier	S23 windscreen, PS418D preamplifier (phantom or battery), 1.5V AA alkaline battery
Packaging	White box	White box	White box	White box

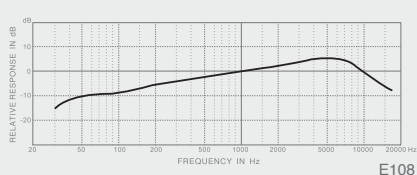
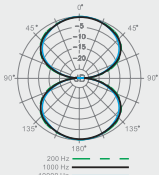



**Portable mini-PAs**



## MA818 Portable Mini PA System

### Tour Guide / School Teacher / Presenter

The MA818 is a lightweight portable PA with a rechargeable battery and can work with a variety of microphones for convenient speaking and music reinforcement. It comes with a shoulder strap for voice-on-the-move and is a convenient PA tool for school, church, presentations, and tour guides. There is a 5/8" thread located at the bottom for mounting the MA818 onto a microphone stand.

- Lightweight and portable, allowing easy handling, hanging on the shoulder, or placing on a mic stand or table
- 4-hours charge can give 8 hours of continuous use
- 1/8" (3.5 mm) stereo mini connector can accept MP3 players or other audio sources
- Power saving circuitry design
- Highly intelligent voice and convenient PA tool
- Battery or AC power
- Can reach an audience of 200

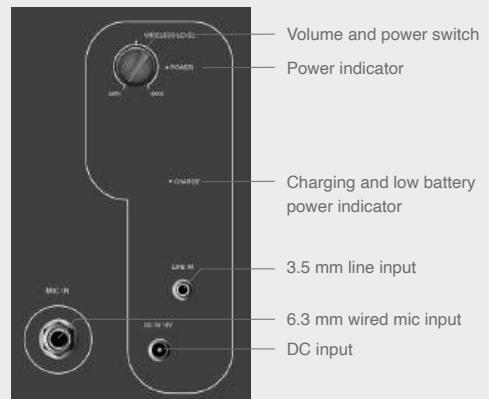

### Specifications

Max. Output Power	27 W/4Ω (external power supply)
Frequency Response	50-18,000 Hz
THD	< 1%
Battery	12 V 2.7AH rechargeable battery pack
Driver	5" high efficient driver
Audio Inputs	6.3 mm (1/4") phone jack for microphone; 3.5 mm (1/8") stereo mini jack for line source
Power Requirements	Internal 12 V/2.7 AH recharging battery
Recharging Time	4 hours charging, 8 hours operation
Dimensions, Weight	285 × 160 × 178 mm (11.2" × 6.3" × 7" in.), Weight: 3 kg (6.6 lbs)



MA818 / 105	MA818 / 106	MA818 / 108	MA818 / 210	MA818 / 10A	MA818 / 535NC
<b>Headworn Cardioid</b>	<b>Handheld Pack</b>	<b>Headworn Figure 8</b>	<b>Lavalier Pack</b>	<b>Handheld Pack</b>	<b>PTT NC Pack</b>

The MA818 is packaged with an E105 headworn cardioid microphone for hands-free operation. It is perfect for smaller, quiet spaces with warmer sound.

- Accessories Furnished: 3.5 mm to 6.3 mm adapter

The MA818 is packaged with a D106 handheld supercardioid microphone and matched with an HM42A mic clip. In a smaller and quiet space, this popular style microphone with minor proximity effect meets expectations.

- Optional Accessories: DS106 table stand

The MA818 is packaged with an E108 headworn figure-8 microphone for hands-free operation and background noise rejection.

- Accessories Furnished: 3.5 mm to 6.3 mm adapter

The MA818 is packaged with an EM210 lavalier microphone.

- Accessories Furnished: 3.5 mm to 6.3 mm adapter

The MA818 is packaged with a D10A omni microphone with no proximity effect and tuned frequency response for good intelligibility.

- Accessories Furnished: 3.5 mm to 6.3 mm adapter

The MA818 is packed with a PRA535NC / PTT microphone for best background noise rejection.



## MA500

### Personal Voice Enhancer

#### School Teacher / Mobile Retail Stand / Tour Guide

MA500 is a lightweight personal voice enhancer and can work with a variety of microphones for convenient speaking reinforcement. Very lightweight portable PA can be strapped to waist as a belt pack.

It can be powered by 6 AA alkaline batteries or rechargeable batteries. Featuring high efficient 2.5" driver driven by 5-watt amplifier, it is specially designed for kindergarten teacher and mobile retail stands.

- Lightweight and can be strapped to waist
- Mic and line inputs
- Volume and power switch control
- 1/8" (3.5 mm) stereo mini connector can accept MP3 player or other audio sources
- Powered by 6 AA alkaline batteries (not included) that provide up to 8 hours of operation
- Included charging circuitry, optional DC power adapter is available

#### Specifications

Max. Output Power	5W / 4Ω
Audio Inputs	2 × 3.5 mm (1/8") stereo mini jack, one for microphone and the other for line source
Power Requirements	6 × 1.5V AA alkaline batteries
Recharging Circuitry	MA500 can be used as a charger, the rechargeable battery should be Ni-MH or Ni-CD and its capacity should be lower than 1300 mA. Recharging time is around 10 to 15 hours
Battery Life	6 × AA alkaline batteries, 8 hours continuous operation
Drivers	2.5"
Net Weight	320 g (11.3 oz)



#### MA500 / 105

##### Headworn Cardioid

The MA500 is packaged with an E105 headworn cardioid microphone for hands-free operation. It's suited to smaller, quiet spaces with warmer sound.

#### MA500 / 108

##### Headworn Figure 8

The MA500 is packed with an E108 Headworn Figure 8 microphone for hands-free operation and background noise rejection.

#### MA500 / 210

##### Lavaliere Pack

The MA500 is packaged with an EM210 lavalier microphone integrated 1.5-meter cable. EM210 features an omnidirectional polar pattern and provides a clear vocal sound.

#### MA500 / 10A

##### Handheld Pack

MA500 is packaged with a D10A omnidirectional microphone with no proximity effect and tuned frequency response for good intelligibility.



HD660 PRO  
150Ω

Superlux

HARD  
HEADPHONE  
AMPLIFIER

OFF ON  
POWER

LOOP  
OUT

STEREO LOOP IN

PEAK

# **Cables Stands, Mounts and Racks**

### CFM Balanced Signal Cable CFI Instrument Signal Cable

Conduct Area	AWG#26, 0.13 mm <sup>2</sup>	AWG#26, 0.13 mm <sup>2</sup>
Composition of Conductor	10 × 0.12 mm bare copper + 2 × 1# (0.23 mm) copper foil and wire	10 × 0.12 mm bare copper + 2 × 1# (0.23 mm) copper foil and wire
Conductor Isolation	PE	PE
Composition of Cores	2 cores twisted	1 core
Pair Screen/Screen	Spiral wound Aluminum foil	spiral wound Aluminum foil
Overall Jacket	PVC black	PVC black
Overall Diameter	6 ± 0.2 mm	6 ± 0.2 mm
Weight	45 g/m	45 g/m
Working Temperature: mobile	-15°C ~ +90°C	-15°C ~ +90°C
Working Temperature: fixed	-20°C ~ +90°C	-20°C ~ +90°C
Conductor Resistance (Ω/km)	140 Ω	140 Ω
Capacity (cond./cond.)	35 pF/m	35 pF/m
Capacity ( cond./screen)	80 pF/m	80 pF/m
Test Voltage	400 V	400 V

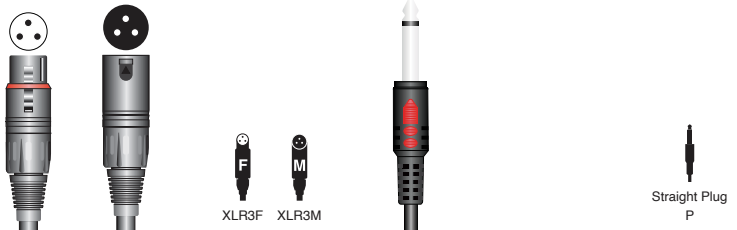

#### Balanced Signal Cable

Conduct Area: AWG#26, 0.13 mm<sup>2</sup>  
 Composition of Conductor: 10 × 0.12 mm bare copper + 2 × 1# (0.23 mm) copper foil and wire  
 Screen: Spiral wound aluminum foil

#### Instrument Signal Cable

Conduct Area: AWG#26, 0.13 mm<sup>2</sup>  
 Composition of Conductor: 10 × 0.12 mm bare copper + 2 × 1# (0.23 mm) copper foil and wire  
 Screen: Spiral wound aluminum foil

#### XLR3F~XLR3M

Model No.	Length
CFM0.5FM	0.5 M
CFM1FM	1 M
CFM2.5FM	2.5 M
CFM5.0FM	5 M
CFM7.5FM	7.5 M
CFM10FM	10 M

#### Dual Straight 6.3 mm (1/4") Mono Plugs

Model No.	Length
CFI0.3PP	0.3 M
CFI0.6PP	0.6 M
CFI0.9PP	0.9 M
CFI1.5PP	1.5 M
CFI3PP	3 M
CFI4.5PP	4.5 M
CFI6PP	6 M
CFI9PP	9 M

#### Unbalanced Signal Cable

Conductor Area: AWG#26, 0.13 mm<sup>2</sup>  
 Composition of Conductor: 10 × 0.12 mm bare copper + 2 × 1#(0.23 mm) copper foil and wire  
 Screen: Spiral wound aluminum foil

#### XLR3F~ 6.3 mm (1/4") mono plugs

Model No.	Length
CFM5FP	5 M
CFM7.5FP	7.5 M
CFM10FP	10 M

# FAIRLINE Series

## SFI Instrument Signal Cable SFS Speaker Cable

## SFM Balanced Signal Cable

Conductor Area	AWG#24, 0.2 mm <sup>2</sup>	AWG#14, 2.08 mm <sup>2</sup>	AWG#24, 0.2 mm <sup>2</sup>
Composition of Conductor	25 x 0.12 mm bare copper	35 x 0.25 mm bare copper	25 x 0.12 mm bare copper
Conductor Isolation	PE	PVC	PE
Composition of Conductor	1 core	2 core twisted	2 core twisted
Pair Screen / Screen	48 wires, spiral wound copper wire Screen	spiral wound tissue paper	96 wires, spiral wound copper wire Screen
Overall Jacket	PVC black	PVC black	PVC black
Overall Diameter (mm)	6 ± 0.2 mm	8 ± 0.3 mm	6 ± 0.2 mm
Weight	47 g/m	95 g/m	51 g/m
Working Temperature: mobile	-15°C ~ +90°C	-15°C ~ +90°C	-15°C ~ +90°C
Working Temperature: fixed	-20°C ~ +90°C	-20°C ~ +90°C	-20°C ~ +90°C
Conductor Resistance Ω/km	49 Ω	7 Ω	49 Ω
Capacity (cond./cond.)	120 pF/m	40 pF/m	35 pF/m
Capacity (cond./screen)	---	125 pF/m	100 pF/m
Test Voltage	400 V	500 V	400 V

## FAIRLINE Specialties

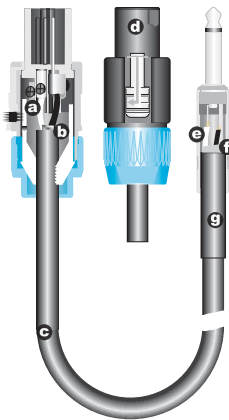

- a AWG14 conductors, high current capacity
- b Cotton filled
- c Ø8 mm speaker cable
- d Reinforced plastic
- e Multiple conductors threaded for flexibility
- f Plated thick brass
- g PVC shrink protective sleeve

**Instrument Signal Cable**  
 Conductor Area: AWG#24, 0.2 mm<sup>2</sup>  
 Composition of Conductor: 25 x 0.12 mm bare copper  
 Screen: 48 wires, spiral wound copper wire screen

**Speaker Cable**  
 Conductor Area: AWG#14, 2.08 mm<sup>2</sup>  
 Composition of Conductor: 35 x 0.25 mm bare copper

**Balanced Signal Cable**  
 Conductor Area: AWG#24, 0.2 mm<sup>2</sup>  
 Composition of Conductor: 25x0.12 mm bare copper  
 Screen: 96 wires, spiral wound copper wire screen

### Bulk Roll 100 meters roll package

Model No.	Model No.	Model No.
SFI100 AWG#24 instrument signal cable	SFS100 AWG#14 speaker cable	SFM100 AWG#24 balanced signal cable

### Color Code (Various color available for bulk roll. Please suffix color code while ordering)

BK Black	BL Blue	YL Yellow	GN Green	GR Grey	RD Red	PL Purple

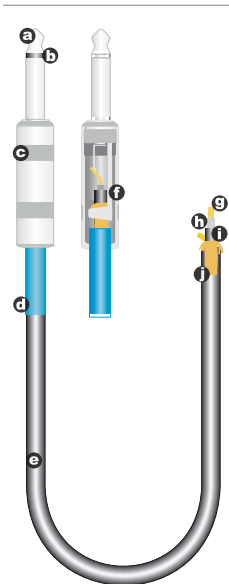

- a Nickel plated brass
- b Nylon insulator
- c Nickel plated brass
- d Nickel plated brass
- e 6 mm high quality instrument cable
- f Plated thick Brass
- g High quality copper
- h PE insulation jacket for low capacitance
- i Conductive PVC to eliminate noise
- j Braided copper shield for 95% coverage

### Dual Angle Mono Plugs 6.3 mm (1/4")

Model No.	Length
SFI0.2RR	0.2 M
SFI0.3RR	0.3 M
SFI0.6RR	0.6 M
SFI0.9RR	0.9 M
SFI1.5RR	1.5 M
SFI3RR	3 M
SFI6RR	6 M

### Dual Straight Mono Plugs 6.3 mm (1/4")

Model No.	Length
SFI0.3PP	0.3 M
SFI0.6PP	0.6 M
SFI0.9PP	0.9 M
SFI1.5PP	1.5 M
SFI3PP	3 M
SFI4.5PP	4.5 M
SFI6PP	6 M

### Angle and straight 6.3 mm (1/4") Mono Plugs

Model No.	Length
SFI0.9PR	0.9 M
SFI1.5PR	1.5 M
SFI3PR	3 M
SFI4.5PR	4.5 M
SFI6PR	6 M
SFI7.5PR	7.5 M

### Dual Speakon Plugs (±1)

Model No.	Length
SFS3SS	3 M
SFS5SS	5 M
SFS10SS	10 M
SFS15SS	15 M
SFS20SS	20 M

### Dual Straight Mono Plugs 6.3 mm (1/4")

Model No.	Length
SFS3PP	3 M
SFS5PP	5 M
SFS10PP	10 M
SFS15PP	15 M
SFS20PP	20 M

### Speakon & Straight Mono 6.3 mm (1/4") Plugs

Model No.	Length
SFS0.9SP	0.9 M
SFS3SP	3 M
SFS9SP	9 M

### XLR3F~XLR3M

Model No.	Length
SFM0.5FM	0.5 M
SFM1.5FM	1.5 M
SFM2.5FM	2.5 M
SFM5.0FM	5 M
SFM7.5FM	7.5 M
SFM10FM	10 M
SFM20FM	20 M

### Unbalanced Signal Cable

Conductor Area: AWG#24, 0.2 mm<sup>2</sup>  
 Composition of Conductor: 25 x 0.12 mm bare copper  
 Screen: 96 wires, spiral wound copper wire screen

### XLR3F~ 6.3 mm (1/4") Mono plugs

Model No.	Length
SFM5FP	5 M
SFM7.5FP	7.5 M
SFM10FP	10 M

# Microphone Stands

**E** Bigfoot Willie. The 3 legs are extendable to enhance stability. A new and patent-pending design.

**BAG** Convenient carrying bag included.

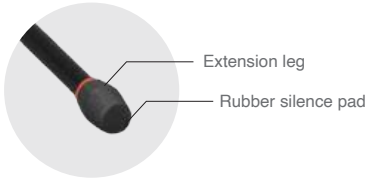

## MS131 E/BAG

### Adjustable Boom Stand

MS131, MS131E/BAG

#### Specifications

Height	90 - 160 cm (2.95' - 5.24')
Boom Length	45 - 80 cm (1.47' - 2.62')
Weight	MS131: 3.1 kg (6.83 lbs)
Material	Iron, plastic
Base	Zinc-alloy die-cast
Accessories Furnished	Mic stand thread adapter 5/8" to 3/8" (MS131E/BAG includes a canvas bag for portability)



## MS108 E/BAG

### Adjustable Boom Stand

MS108E, MS108E/BAG

#### Specifications

Height	90 - 160 cm (2.95' - 5.24')
Boom Length	80 cm (2.62')
Weight	MS108: 2 kg (4.41 lbs)
Material	Iron, plastic
Base	Plastic
Accessories Furnished	Mic stand thread adapter 5/8" to 3/8" (MS108E/BAG includes a canvas bag for portability)



Aluminum Alloy Lock

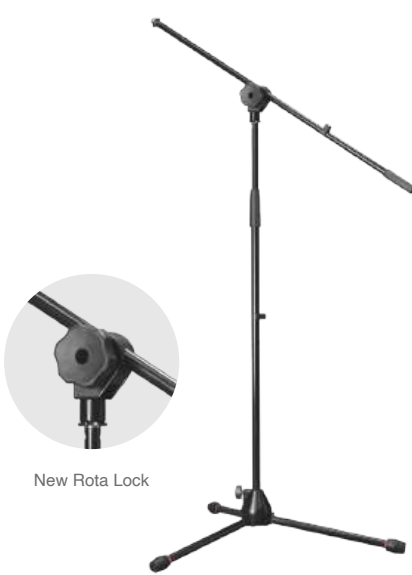

New Rota Lock

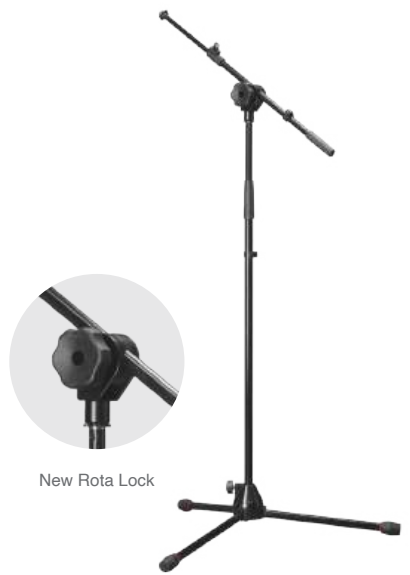

New Rota Lock

## MS141 E/BAG

### Adjustable Boom Stand

MS141, MS141E/BAG

#### Specifications

Height	90 - 160 cm (2.95'-5.24')
Boom Length	80 cm (2.62')
Weight	MS141: 3 kg (6.61 lbs)
Material	Iron, plastic
Base	Zinc-alloy die-cast
Accessories Furnished	Mic stand thread adapter 5/8" to 3/8" (MS141E/BAG includes a canvas bag for portability)

## MS152 E/BAG

### Adjustable Boom Stand

MS152, MS152E/BAG

#### Specifications

Height	90 - 160 cm (2.95'-5.24')
Boom Length	80 cm (2.62')
Weight	MS152: 3 kg (6.61 lbs)
Material	Iron, plastic
Base	Zinc-alloy die-cast
Accessories Furnished	Mic stand thread adapter 5/8" to 3/8" (MS152E/BAG includes a canvas bag for portability)

## MS153 E/BAG

### Adjustable Boom Stand

MS153, MS153E/BAG

#### Specifications

Height	90 - 160 cm (2.95' - 5.24')
Boom Length	45 - 80 cm (1.47' - 2.62')
Weight	MS153: 3 kg (6.61 lbs)
Material	Iron, plastic
Base	Zinc-alloy die-cast
Accessories Furnished	Mic stand thread adapter 5/8" to 3/8" (MS153E/BAG includes a canvas bag for portability)

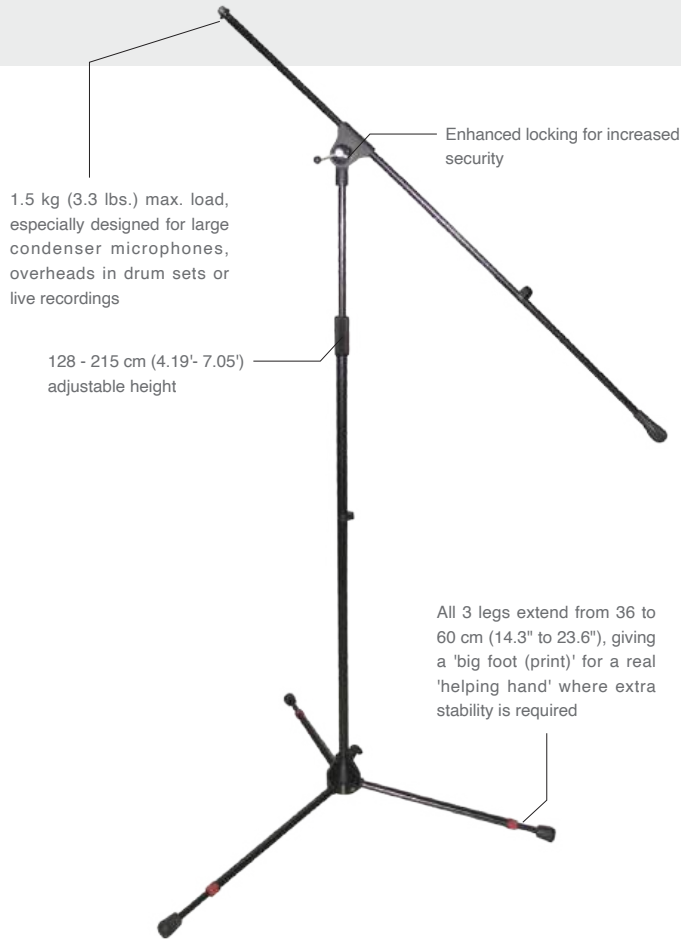

## MS158 E/BAG

### BFW Big Foot Willie Adjustable Boom Stand

Why Bigfoot Willie? Well, since Willie is the guy who designed and built this Bigfoot stand, why not name it after him?

This Bigfoot stand is the answer for those people who want to use a large condenser microphone to reach that sweet spot, but find that the weight and length of these mics can easily tip over an ordinary stand.

Now, simply unscrewing a few turns on the foot you need to extend will provide the right support, making the Bigfoot Willie the perfect way to achieve that desired microphone placement.

#### Specifications

Height	130 - 215 cm (4.26' - 7.05')
Boom Length	120 cm (3.93')
Weight	5.9 kg (13 lbs)
Material	Iron, plastic
Base	Zinc-alloy die-cast
Accessories Furnished	Mic stand thread adapter 5/8" to 3/8", Sturdy canvas bag for portability

## Microphone Stands Without Extension Legs



### MS432

#### Microphone Stand with Dual Height Control Locks

Designed for the Superlux SP108 portable PA system

#### Specifications

Height	52 - 140 cm (1.7' - 4.59')
Weight	1.06 kg (2.33 lbs)
Material	Iron, plastic
Base	Plastic
Accessories Furnished	Microphone stand mounting adapter for the mixer of Superlux SP108 portable sound system



### MS101 /BAG

#### Microphone Stand

#### Specifications

Height	90 - 160 cm (2.95' - 5.24')
Weight	2.5 kg (5.51 lbs)
Material	Iron, plastic
Base	Zinc-alloy die-cast
Accessories Furnished	Mic stand thread adapter 5/8" to 3/8", Sturdy canvas bag for portability

# Microphone Stands Without Extension Legs

This light-weight aluminum stand is a good solution for all vocal, instrumental and travelling musicians.



**MS110**  
Microphone Stand

**Specifications**

Height	80 - 160 cm (2.62' - 5.24')
Weight	3.8 kg (8.37 lbs)
Material	Iron, plastic
Base	Iron
Accessories	Mic stand thread adapter 5/8"
Furnished	to 3/8"

**MS107**  
Microphone Stand

**Specifications**

Height	80 - 160 cm (2.62' - 5.24')
Weight	3.23 kg (7.12 lbs)
Material	Iron, plastic
Base	Iron
Accessories	Mic stand thread adapter 5/8"
Furnished	to 3/8"

**MS108**  
Aluminum Boom Stand

**Specifications**

Height	90 - 160 cm (2.95' - 5.24')
Boom Length	45 - 80 cm (1.47' - 2.62')
Weight	1 kg (2.2 lbs)
Material	Aluminum, plastic
Base	Plastic
Accessories	Mic stand thread adapter 5/8"
Furnished	to 3/8"

**MS128 /BAG**  
Aluminum Boom Stand

**Specifications**

Height	70 - 120 cm (2.29' - 3.93')
Boom Length	62 cm (2.03')
Weight	0.77 kg (1.69 lbs)
Material	Aluminum, plastic
Base	Nylon
Accessories	Mic stand thread adapter 5/8"
Furnished	to 3/8", Sturdy canvas bag for portability



**MS177**  
Tripod Microphone Stand

**Specifications**

Stand Height	90 - 154 cm (2.95' - 5.05')
Boom Length	79 cm (31.1")
Weight	2.5 kg (5.51 lbs)
Base diameter	72 cm (28.3")
Folded size	88.5 x 11.5 cm (34.8" x 4.5")
Material	Iron, plastic
Base	Plastic
Accessories	Mic stand thread adapter
Furnished	5/8" to 3/8"

**MS188**  
Adjustable Boom Stand

**Specifications**

Height	90 - 150 cm (2.95' - 4.92')
Boom length	82 cm (2.69')
Weight	2.1 kg (4.62 lbs)
Material	Iron, plastic
Base	Plastic

**MS200**  
High Rise Stand

**Specifications**

Height	170 - 308 cm (5.58' - 10.1')
Boom Length	122 - 220 cm (4' - 7.22')
Weight	9.75 kg (21.49 lbs)
Material	Iron, plastic
Base	Plastic
Accessories	Mic stand thread adapter 5/8"
Furnished	to 3/8"

**MS300**  
High Rise Stand with Casters

**Specifications**

Height	159 - 226 cm (5.22' - 7.41')
Boom Length	125 - 205 cm (4.1' - 6.72')
Weight	8.2 kg (18.07 lbs)
Material	Iron, plastic
Base	Plastic
Accessories	Mic stand thread adapter 5/8"
Furnished	to 3/8"

# Instrument Stands, Music Stands, Guitar Stands



## MS104 /BAG

### Adjustable Boom Stand

#### Specifications

Height	40 - 50 cm (1.31' - 1.64')
Boom Length	45 - 80 cm (1.47' - 2.62')
Weight	2.6 kg (5.73 lbs)
Material	Iron, plastic
Base	Zinc-alloy die-cast

Accessories  
Furnished

Mic stand thread adapter 5/8" to 3/8". Sturdy canvas bag for portability

## MS105 /BAG

### Adjustable Boom Stand

#### Specifications

Height	35 cm (1.15')
Boom Length	45 - 80 cm (1.47' - 2.62')
Weight	2.38 kg (5.24 lbs)
Material	Iron, plastic
Base	Zinc-alloy die-cast

Accessories  
Furnished

Mic stand thread adapter 5/8" to 3/8". Sturdy canvas bag for portability

## MUS211

### Music Stand

#### Specifications

Height	65 - 110 cm (2.1' - 3.6')
Weight	3.15 kg (6.94 lbs)
Material	Iron
Base	Plastic

## MUS298

### Music Stand

#### Specifications

Height	65 - 130 cm (2.1' - 4.26')
Weight	1.3 kg (2.86 lbs)
Material	Iron
Base	Plastic



## GS518

### Guitar Stand

#### Specifications

Weight	1.2 kg (2.64 lbs)
Material	Iron, plastic

## GS528

### Electric Guitar Stand

#### Specifications

Height	70 - 110 cm (2.3' - 3.61')
Weight	1.55 kg (3.42 lbs)
Material	Iron, plastic

# Table Stands



## HM66

### Mic Table Arms

#### Specifications

Length	0 - 650 mm ± 5 mm
Capacity	2.3 kg (5.07 lbs)
Weight	1.5 kg (3.30 lbs)
C clamp range	0 - 50 mm
Material	Aluminium, Plastic
Accessories	C-type table clamp,
Furnished	Extension rod



## HM90

### Mic Table Arms

#### Specifications

Length	0 - 950 mm ± 5 mm
Capacity	2.0 kg (4.40 lbs)
Weight	1.3 kg (2.86 lbs)
C clamp range	0 - 50 mm
Material	Aluminium, Plastic
Accessories	Furnished C-type table clamp



## HM48B

### Table Arm

#### Specifications

Weight	1.5 kg (3.30 lbs)
Material	Iron
Accessories	HM502 Table edge clamp
Furnished	HM503 Low profile base



## HM58B

### Table Arm

#### Specifications

Weight	1.8 kg (3.96 lbs)
Material	Iron
Accessories	HM502 Table edge clamp
Furnished	HM503 Low profile base



## MTS004

### Table Stand

#### Specifications

Height	30 - 45 cm (0.98' - 1.47')
Weight	2.4 kg (5.29 lbs)
Material	Iron, plastic
Base	Iron
Accessories	Mic stand thread adapter 5/8"
Furnished	to 3/8"



## MTS014

### Table Stand

#### Specifications

Height	40 - 50 cm (1.31' - 1.64')
Boom Length	37 cm (1.21')
Weight	2.61 kg (5.75 lbs)
Material	Iron, plastic
Base	Iron
Accessories	Mic stand thread adapter 5/8"
Furnished	to 3/8"



## MTS024

### Table Stand

#### Specifications

Height	40 - 60 cm (1.47' - 1.96')
Weight	2.5 kg (5.51 lbs)
Material	Iron, plastic
Base	Iron
Accessories	Mic stand thread adapter 5/8"
Furnished	to 3/8"



## HM6

### Table Stand

#### Specifications

Thread	3/8" Thread
Height	15 - 22 cm (0.49' - 0.72')
Weight	0.35 kg (0.77 lbs)
Material	Zinc-alloy, plastic
Accessories	HM9 Mic Clip, YA1 5/8" - 3/8"
Furnished	Threaded Adapter



## DS01

### Table Stand

#### Specifications

Thread	5/8" Thread
Height	110 mm (0.36')
Weight	0.1 kg (0.22 lbs)
Material	Iron
Base	plastic

## DS011

### Table Stand

#### Specifications

Thread	5/8" Thread
Height	9 cm (0.29')
Weight	0.13 kg (0.28 lbs)
Material	Iron
Base	plastic

## D1

### Table Stand

#### Specifications

Thread	5/8" Thread
Height	12 cm (0.39')
Weight	0.5 kg (1.1 lbs)
Material	Iron
Base	Iron

## HM502

### Table Edge Clamp

## HM503

### Low Profile Base



# Speaker Stands



## LS718S Crank Speaker Stand

### Specifications

Height	150 - 270 cm (4.92' - 8.85')
Capacity	60 kg (132.27 lbs)
Weight	12 kg (26.45 lbs)
Material	Iron, plastic



Designed for supporting a main speaker on top of a subwoofer where the main speaker incorporates a standard 35 mm (1 3/8") diameter speaker stand socket in its base.

## SPA01 Subwoofer Stand

### Specifications

Height	92 - 160 cm (3.01' - 5.24')
Capacity	50 kg (110.23 lbs)
Weight	1.73 kg (3.81 lbs)
Material	Iron, plastic



## SPS410A Aluminum Speaker Stand

### Specifications

Height	110 - 200 cm (3.6' - 6.56')
Capacity	50 kg (110.23 lbs)
Weight	2.71 kg (5.97 lbs)
Material	Aluminum alloy, plastic
Finish	SPS410A: Aluminum original; SPS410AB: Black



## SPS410B Speaker Stand

### Specifications

Height	115 - 200 cm (3.77' - 6.56')
Capacity	50 kg (110.23 lbs)
Weight	5.0 kg (11.01 lbs)
Material	Iron
Finish	Black



## SPSK1 Speaker Stand Package

- Includes:
- 1 SPS410B speaker stand
  - 1 SPA01 subwoofer pole
  - 1 Large carrying canvas bag

## SPSK2 Speaker Stand Package

- Includes:
- 2 SPS410B speaker stand
  - 1 Large carrying canvas bag



## SPE202

### Speaker Floor Stand

#### Specifications

Height	113 - 160 cm (3.7' - 5.24')
Weight	2.78 kg (6.12 lbs)
Material	Iron
Base	plastic



## SPE428

### Speaker Floor Stand

#### Specifications

Height	120 - 180 cm (3.94' - 5.91')
Weight	2.4 kg (5.29 lbs)
Material	Aluminum, plastic
Base	plastic



## SPS410AB

### Aluminum Speaker Stand

#### Specifications

Height	115 - 200 cm (3.77' - 6.56')
Maximum Load	50 kg (110.23 lbs)
Weight	5 kg (11.01 lbs)
Material	Aluminum alloy, plastic
Base	plastic



Useful for a 10" or smaller speaker

## SPS400

### Indoor Speaker Stand

#### Specifications

Height	100 - 150 cm (3.28' - 4.92')
Maximum Load	20 kg (44.09 lbs)
Weight	2.92 kg (6.43 lbs)
Material	Iron



## SPS430L

### Monitor Speaker Stand

#### Specifications

Height	80 - 145 cm (2.62' - 4.75')
Maximum Load	20 kg (44.09 lbs)
Weight	3.6 kg (7.93 lbs)
Material	Iron

# Speaker Stands & Mounts

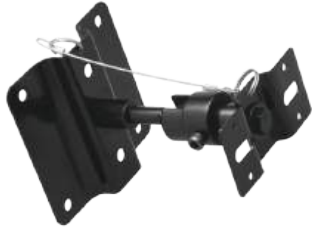

## SPS838

Ceiling / Wall Mount

### Specifications

Maximum Load	10 kg (22.04 lbs)
Weight	0.46 kg (1.01 lbs)
Material	Iron

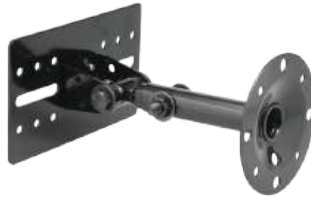

## SPS867A

Ceiling / Wall Mount

### Specifications

Maximum Load	25 kg (55.11 lbs)
Weight	1.03 kg (2.27 lbs)
Material	Iron, plastic



## SPS869

Ceiling / Wall Mount

### Specifications

Maximum Load	20 kg (44.1 lbs)
Weight	0.9 kg (1.98 lbs)
Material	Iron



## SPS878

Ceiling / Wall Mount

### Specifications

Maximum Load	35 kg (77.16 lbs)
Weight	1.8 kg (3.96 lbs)
Material	Iron



## SPS813

Wall Mount

### Specifications

Maximum Load	50 kg (110.23 lbs)
Weight	6 kg (13.22 lbs)
Material	Iron, plastic



## SPS823

Wall Mount

### Specifications

Maximum Load	35 kg (77.16 lbs)
Weight	1.8 kg (3.96 lbs)
Material	Iron, plastic



## MA08

Wall Mount Microphone Holder

### Specifications

Weight	0.17 kg (0.375 lbs)
Material	Iron, plastic



## MA09

Wall Mount Microphone Holder

### Specifications

Weight	0.18 kg (0.397 lbs)
Material	Iron, plastic

# Racks



## RS908

### 8U Rack

#### Specifications

Weight	14.8 kg (32.63 lbs)
Material	Iron
Dimensions (with wheel)	H48.8 × W50.7 × D46.0 cm (H1.6' × W1.66' × D1.51' ft.)
Accessories Furnished	Empirical and metric screws



## RS912

### 12U Rack

#### Specifications

Weight	16.4 kg (36.16 lbs)
Material	Iron
Dimensions (with wheel)	H66.6 × W50.7 × D46.0 cm (H2.19' × W1.66' × D1.51' ft.)
Accessories Furnished	Empirical and metric screws



## RS916

### 16U Rack

#### Specifications

Weight	17.6 kg (38.8 lbs)
Material	Iron
Dimensions (with wheel)	H84.5 × W50.7 × D46.0 cm (H2.77' × W1.66' × D1.51' ft.)
Accessories Furnished	Empirical and metric screws



## RS921

### 21U Rack

#### Specifications

Weight	21 kg (46.3 lbs)
Material	Iron
Dimensions (with wheel)	H106.5 × W50.7 × D46.0 cm (H3.49' × W1.66' × D1.51' ft.)
Accessories Furnished	Empirical and metric screws



Cables are not included

## DS70

### Display Rack

#### Specifications

Weight	10 kg (22.04 lbs)
Material	Iron
Dimensions	H160 × W25 cm (H5.24' × W0.82' ft.)
Accessories Furnished	20 display hooks



# Grille Nets, Adapters and Gooseneck LED Lights

Flash recorders are becoming increasingly popular for those who do recording outside. When doing long-term recording, a stand is a necessity, and most stands available for a professional sound engineer are microphone stands. How do you install a flash recorder on a microphone stand? Now the YA28 and YA38 ball head adapters can solve this problem.

For the popular smaller and lighter recorders or microphones, a light-weight yet sturdy stand is needed that can withstand the rigors of frequent travelling. The Superlux MS108AB light-weight aluminum stand, coupled with the YA28 or YA38 adapter, is the answer to this demand.



For Mic stands



For Camera stands



For Camera stands



## YA18

### Ball Head

#### Specifications

Thread	3/8" bolt with 5/8" thread
Dimensions	
Weight	
Material	Iron, plastic

## YA28

### Ball Head

#### Specifications

Thread	1/4" bolt with 5/8" thread
Dimensions	
Weight	
Material	Iron, plastic

## YA38

### Ball Head

#### Specifications

Thread	1/4" bolt with 5/8" thread
Dimensions	
Weight	
Material	Iron, plastic

## FO58

### Grille Net

#### Specifications

Thread	Thread 1 - 1/4" - 32
Dimensions	H50.22 mm, Ø50.41 mm
Weight	39.8 g
Material	Iron



## L01U

### Gooseneck LED Light with USB Connector

The L01U gooseneck LED lights are the perfect accessory for any equipment with USB power and includes a power ON/OFF switch for saving power. These flexible lights provide an ample amount of light when working in a dark area.

- Eight-segment LED light for enhanced illumination
- Cool, energy-efficient illumination
- Long lasting LED lights that rarely need replacing
- ON/OFF switch

#### Specifications

Length	405 mm (16")
Power consumption	130 mA - 140 mA
Power requirement	USB - HUB, 5V DC
Dimensions	
Weight	
Material	



## L02X

### Gooseneck LED Light with XLR Connector

The L02X gooseneck LED lights are perfect for mixing consoles, DJ mixers, power conditioners or any electronic device that has an XLR-F jack and 12V power available. These flexible lights provide an ample amount of light when working in a dark area.

- Eight segment LED light for enhanced illumination
- Cool, energy-efficient illumination
- Long-lasting LED lights that rarely need replacing

#### Specifications

Length	370 mm (14.6")
Power consumption	40 mA - 50 mA
Power requirement	11.5V - 13.0V DC
Dimensions	
Weight	
Material	



**Superlux**

DYNAMIC STEREO HEADPHONES

HD572

R

**Superlux**

DYNAMIC STEREO HEADPHONES

HD572

# Which Microphone for You?

Facing a variety of microphones, how do you find the right one for your application? This question could be put this way: "Which mic is the best?" Yes, if the answer were that easy, maybe there would only be one microphone in the world to fulfill all your demands. Since your demands differ, the answer varies accordingly.

## Which type of transducer?



### Dynamic

With a durable and simple structure, it operates in all kinds of environments. A good dynamic microphone is capable of operating at a very high sound pressure level without distortion. Due to structural limits, dynamics cannot be as small as a condenser, but dynamics don't require power to operate.



### Condenser

With an extremely light weight diaphragm, it is very sensitive to sound. Very small versions are available for hidden applications. High performance condenser microphones are regarded as standard equipment in recording studios for extreme detail capturing. They operate with phantom or battery power.

## Which kind of directivity?



### Omni

With equal sensitivity in all directions, an omni microphone doesn't need to point toward the sound source. It features low handling and wind noise. It is welcomed for news gathering and music recording applications.



### Cardioid

It picks up most signal on axis, rejects side noise, and picks up least to the back. It is suitable for live sound reinforcement. With its apparent proximity effect, most singers like to take advantage of the bass boost but cardioid mics are not good for speech.



### Supercardioid

A supercardioid is narrower than a cardioid pattern and is suitable for a multiple microphone setup. It is least sensitive toward the side and rear, where most stage monitors are located. It has the same proximity effect as a cardioid microphone.



### Figure 8, bi-directional

It is equally sensitive to both ends, and rejects the sides. It is good in a noisy environment because it rejects distant noise and low frequencies. It is also a good choice for stereo recordings, such as Blumlein. It features a typical pressure gradient characteristic.



### Shotgun

Based on interference tube theory, this mic achieves the highest axial signal pick-up and rejects off-axis sound as much as possible. Due to poor wind noise rejection, a suitable wind screen should be used outdoors.

## About Frequency Response

### Flat

This is suitable for working in a controlled environment, or for acoustic measurements. Although people pursue flatness, it is a challenge for non-professionals to make it work as expected.

### Popular Curve Response

This is based on years of practical experience by pro users. There are curves designed for various applications, so that it is very simple to use the microphone. Its strengths are limiting bandwidth and emphasizing sounds.

### Variable Response

This incorporates switchable filters to eliminate interference, such as sub-sonic filter to cut air-conditioner and floor vibrations. It allows full flat when used in a controlled environment.

# Stereo Recording Techniques

## ORTF Technique

ORTF stands for "Office de Radiodiffusion Television Francaise". This standard was established for stereo broadcasting that brings optimal stereo performance to most audio systems. Two cardioid capsules are arranged with a 110° open angle and 17 cm separation. The benefits of ORTF are that it brings more a spacious sound than the XY technique, yet avoids the "hole in the center" problem of the spaced AB technique that exhibits very good spacious sound.

The ORTF technique uses balanced stereo positioning, and produces a spacious sound that pleases an audience more than the AB or XY/MS stereo techniques. ORTF is a technique that can be easily handled by beginners or video production crews with a fixed ORTF stereo microphone such as the Superlux S502. Experienced engineers can also take advantage of this with the S502, or use a pair of S241s with the stereo bracket model HM15 or MA90 for ORTF recording.

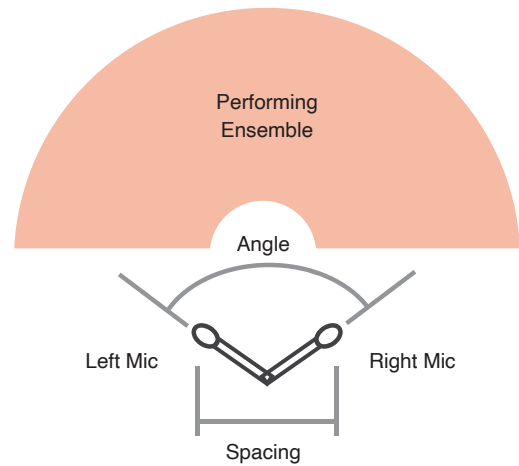
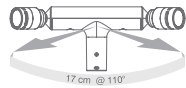

## XY Technique

XY stereo recording employs two identical directional microphones located in the same place, and typically placed off axis at 90° or more to each other. A stereo effect is achieved through differences in sound pressure level between two microphones and varies by the microphone directivity character and the angle between the two microphones.

The following models from Superlux are permanently installed XY stereo microphones: E522B \ E523D \ E524D \ E532B \ E525 (stereo shotgun) \ E503U (USB stereo)

Through two separate directional microphones (like S241 or CMH8K) plus a dual microphone adapter or bar (like the C2, HM15 or MA90), you can also have an XY stereo recording setup.

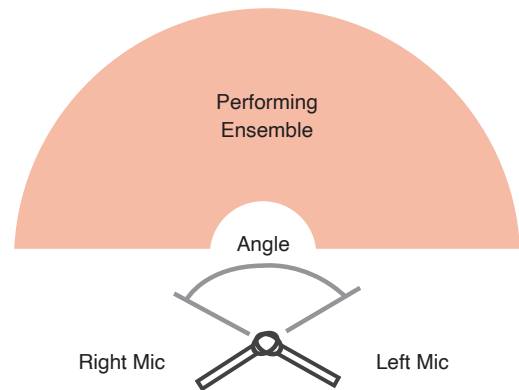

## MS Technique

MS comes from a Mid and a Side microphone. This coincident technique employs a cardioid microphone pointing to the sound source (Mid) and a bidirectional microphone facing sideways (Side). One mic is physically inverted over the other, so they share the same distance. When the Mid and the Side microphone signal is mixed, the polar pattern became a directional microphone pointing toward the left. And when mixing the Mid and Side in reverse phase, the polar pattern is the same as a directional microphone pointing toward the right. Less Mid and more Side signal will make the polar point toward the outer angle. And more Mid and less Side signal will make the pole point toward center.

The beautiful thing about MS decoded stereo is you can always go back to mono by simply mixing the L and R to mono, and the Mid signal comes back with almost no Side signal. Knowledgeable users tend to use this type of microphone with MS output, and manipulate the MS decoding at the post production stage to determine the result he/she preferred. This makes it especially useful for film-based projects. Since the stereo image width can be altered by changing the Side level, some stereo microphones claim they achieve the same "Zoom" effect as a video zoom lens. Now you can achieve the same result by setting the microphone at MS output, and use any popular NLE audio production software to get the effect you want.

Superlux offers the following models with permanent MS arrangement for your easy stereo recording setup: E525S and E525L: short and long shotguns for broadcasting, E531: compact microphone for camcorder users, E502U: USB microphone for recording

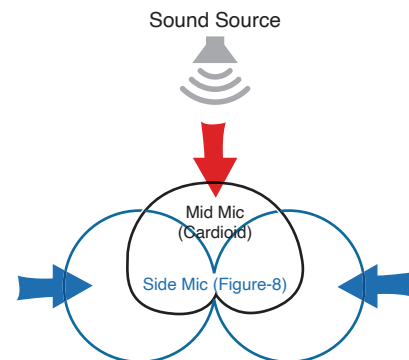

# Product Index

## A

A/HD381 122

## B

B/HD681 122  
 BES3.5 137  
 BES5 137  
 BES5A 138  
 BP101 77

## C

C2 90  
 CFI樂器線 164  
 CFM平衡式訊號線 164  
 CM9HL 15  
 CMH8A 5  
 CMH8AH 6  
 CMH8AMKII 3  
 CMH8B 5  
 CMH8BH 6  
 CMH8C 5  
 CMH8CH 6  
 CMH8D 4  
 CMH8E 13  
 CMH8G 4  
 CMH8K 11  
 CP818 87  
 CP828 87  
 CP838 87

## D

D1 170  
 D103 30  
 D107 29  
 D108 29  
 D108MKII 22  
 D109 30  
 D10B 44  
 D112 41  
 D302 65  
 D401S 73  
 D421 13  
 DMC01 91  
 DMC02 91  
 DMC03 91  
 DRK681 52  
 DRKA3 54

DRKA3C2 54  
 DRKA5 55  
 DRKA5C2 55  
 DRKB5C2MKII 52  
 DRKF5H3 53  
 DRKK5C2 53  
 DS002 68  
 DS003 68  
 DS01 170  
 DS011 170  
 DS70 174

## E

E100 45  
 E101 41  
 E102 45  
 E109 48  
 E10A 35  
 E10B 35  
 E124D 44  
 E12A 36  
 E205 11  
 E205U 19  
 E205UMKII 19  
 E302 79  
 E303 69  
 E304 69  
 E306 65  
 E308 72  
 E309DPRO 66  
 E321 62  
 E322 63  
 E323 71  
 E324 71  
 E326PRO 62  
 E361 67  
 E431U 18  
 E523D 14  
 E524D 8  
 E525 17  
 ECM888B 78  
 ECM999 78  
 ECM999U 80  
 ECO88S 33  
 ECOA1 33

## F

FH12 31  
 FI10 31  
 FK2 47  
 FMX22D 142

FO58 175  
 FS6 47  
 FT4 47

## G

GM13D 68  
 GM13G 68  
 GS518 169  
 GS528 169  
 GT2B 68  
 GT6F 68

## H

HA1D 141  
 HA3D 140  
 HA40 140  
 HA4D 141  
 HD330 107  
 HD330PRO 94  
 HD351 115  
 HD361 114  
 HD381 116  
 HD386 115  
 HD387 113  
 HD387i 113  
 HD440 111  
 HD562 110  
 HD572 105  
 HD572A 106  
 HD581 111  
 HD631 109  
 HD651 112  
 HD660 107  
 HD660PRO 94  
 HD661 102  
 HD662 103  
 HD662EVO 98  
 HD665 109  
 HD667 108  
 HD668B 101  
 HD668BMKII 95  
 HD669 100  
 HD671 97  
 HD672 97  
 HD681 104  
 HD681AIR 99  
 HD681EVO 98  
 HD685 110  
 HD687 96  
 HD688 96  
 HI10 48

HM10 88  
 HM101A 88  
 HM12A 91  
 HM12C 91  
 HM12C 91  
 HM12CA 91  
 HM12CB 91  
 HM12D 91  
 HM12D 91  
 HM12DA 91  
 HM12DB 91  
 HM12DC 91  
 HM12DD 91  
 HM12E 91  
 HM12F 91  
 HM12G 91  
 HM15 90  
 HM16 88  
 HM18AG 87  
 HM20 87  
 HM22 68  
 HM23 68  
 HM24 68  
 HM24C 68  
 HM25 91  
 HM26A 89  
 HM26B 89  
 HM26C 89  
 HM29 88  
 HM30 89  
 HM31 89  
 HM32 89  
 HM33 89  
 HM35 89  
 HM35C 88  
 HM37 88  
 HM38 88  
 HM39 88  
 HM40 90  
 HM40C 88  
 HM42 88  
 HM43 87  
 HM48B 170  
 HM502 170  
 HM503 170  
 HM54 90  
 HM56 89  
 HM56B 89  
 HM57 89  
 HM57E 89  
 HM58B 170  
 HM6 170  
 HM60 89  
 HM61 89  
 HM66 170

HM7	89	MSK124	59	RS916	174	SPS430L	172
HM8	88	MSKA	58	RS921	174	SPS813	173
HM9	88	MTS004	170			SPS823	173
HM90	170	MTS014	170			SPS838	173
HMC631	121	MTS024	170	<b>S</b>		SPS867A	173
HMC660	118	MUS211	169			SPS869	173
HMC660PRO	117	MUS298	169	S02	92	SPS878	173
HMC681EVO	120			S04	92	SPSK1	171
HMD660	118	<b>P</b>		S05F	92	SPSK2	171
HMD660PRO	117			S07F	92		
HMD685	119			S08F	92	<b>T</b>	
HMD685a	77	PINK STICK	79	S09	92		
HMD685a	119	PRA116B	16	S09F	92	TM58	23
HMD685aMKII	120	PRA118	16	S11	92	TOP248	25
HO8	46	PRA20	34	S125	8	TOP258	26
		PRA218A	50	S125	24		
		PRA218B	50	S13F	92		
		PRA228A	51	S14	92	<b>U</b>	
		PRA268A	51	S15	92		
		PRA288A	43	S241	9	UK3	82
		PRA30	34	S25	92	UK82	82
		PRA318	14	S40	92		
		PRA383	40	S502	10		
		PRA418	70	S502MKII	10	<b>V</b>	
		PRA428	70	S65	92		
		PRA448	74	SE108	135	VT9	83
		PRA518	63	SE108W	135		
		PRA52	72	SF10A	133		
		PRA528	64	SF10D	126	<b>W</b>	
		PRA528DS	67	SF110A	131		
		PRA535	73	SF112A	131	WH5	28
		PRA535NC	74	SF115A	131	WO518	37
		PRA538	66	SF118AS	130	WSK1	15
		PRA618	64	SF12A	133	WU518	37
		PRA628MKII	49	SF12AS	132		
		PRA638	49	SF12D	127		
		PRAC	32	SF12DS	128	<b>Y</b>	
		PRAD	32	SF15A	133		
		PRO218A	42	SF15AS	132	YA1	88
		PRO228A	42	SF15D	127	YA10	88
		PRO238C	25	SF15DS	128	YA18	175
		PRO238MKII	7	SF18DS	129	YA2	88
		PRO238MKII	24	SF8	134	YA28	175
		PRO248	26	SF8A	134	YA3	88
		PRO258	27	SF8D	126	YA38	175
		PRO268B	43	SFI樂器線	165	Y-SPLIT	114
		PS2A	86	SFM平衡式訊號線	165		
		PS2B	86	SFS喇叭線	165		
		PS418D	86	SK110	136		
		PS418S	86	SK112	136		
		PS518	68	SP108	124		
		<b>R</b>		SP110	124		
				SPA01	171		
		R102	12	SPE202	172		
		R102MKII	12	SPE428	172		
		RS908	174	SPS400	172		
		RS912	174	SPS410A	171		
				SPS410AB	172		
				SPS410B	171		