



CONNECTING THE FUTURE

# Conference Solution





**CONNECTING THE FUTURE**

# | CONTENT

<b>WIRELESS AUDIO CONFERENCE SYSTEM</b>	<b>02</b>
<b>CONTROLLER &amp; VIDEO PROCESSOR FOR WIRELESS AUDIO CONFERENCE SYSTEM</b>	<b>03</b>
<b>WIRED AUDIO CONFERENCE SYSTEM</b>	<b>04</b>
<b>CONTROLLER &amp; VIDEO PROCESSOR FOR WIRED AUDIO CONFERENCE SYSTEM</b>	<b>05</b>
<b>WIRED SHORTGUN / BOUNDARY CONFERENCE SYSTEM</b>	<b>06</b>
<b>FEEDBACK SUPPRESSOR FOR CONFERENCE MICROPHONE</b>	<b>07</b>
<b>HD VIDEO MATRIX 4x4</b>	<b>07</b>
<b>EXTENSION UNIT FOR WIRED CONFERENCE SYSTEM</b>	<b>08</b>
<b>DISCUSSION AUDIO CONFERENCE SYSTEM</b>	<b>09</b>
<b>RETRACTABLE AUDIO CONFERENCE SYSTEM AND CONTROLLER</b>	<b>10</b>
<b>DIGITAL CONFERENCE CONTROLLER</b>	<b>11</b>
<b>NETWORK DIGITAL CONFERENCE SYSTEM</b>	<b>12</b>
<b>IR CLASSROOM MICROPHONE SOLUTION</b>	<b>13</b>

# WIRELESS AUDIO CONFERENCE SYSTEM



## MX CSM 100C (Chairman)

### Wireless Chairman Microphone

- Wireless Chairman Microphone
- Chairman microphone can turn on any time.
- The system support Video camera auto-track function, chairman microphone.
- ID number should be 1
- Priority function: Chairman can mute delegate microphones by a press of priority button.
- Chairman only mode: Delegate microphone cannot be turned on again after.
- Chairman microphone press priority button.



## MX CSM 100D (Delegate)

### Wireless Delegate Microphone

- Wireless communication system eliminates the need of connecting the conference
- Portable table moving and microphone can be pull out. Extended length option.
- Electric capacity type microphone, equipped with windshield cover
- microphone ID, battery level, microphone state, control channel, etc.
- Equipped with microphone on/off key and indicator.
- Equipped with 3 function keys to set microphone id, control channel, volume level and battery status.
- Microphone will shut off the power or in standby if receiver is powered off.



# CONTROLLER & VIDEO PROCESSOR FOR WIRELESS AUDIO CONFERENCE SYSTEM



## MX CSM 200R (Controller)

### Wireless Conference Controller

- The Wireless Conference System Mx CSM-200R Series Supports The Limit (1/2/3/4), FIFO(1/2/3/4) And Chairman Only Modes.
- One System Support 1000 Microphones For Discussing And 256 Microphones For Video Tracing Function.
- 5 Microphones Can Be Turned On At The Same Time.
- The Microphone Can Be Powered By The Built-in Rechargeable Battery Or Dc Power Supply.
- The Battery Could Last Approximate 8 Hours For Conversation And 30 Hours When Standby.
- Chairman only mode: Delegate microphone cannot be turned on again after.
- Built-in USB recording module.



## MX CSM 600W (Processor)

### Wireless Conference Video Processor

- Support central control system with RS232 interface.
- Support PELCO-D and VISCA communication protocol.
- Control and preset camera by software or processor front panel.
- Support up to 256 preset tracking points in one system.
- RS232/RS422/RS485/USB interface for camera control.
- RS232/RJ45(DATA) /USB interface for conference main unit connection.
- RS232/RS422/RS485 interface for camera control.
- Support more cameras and more video connection interface by connecting HD Hybrid Matrix.



# WIRED AUDIO CONFERENCE SYSTEM



## MX CSM 300C (Chairman)

### Wired Chairman Microphone

- Highly flexible & customizable system supporting 4 Chairman & 260 Delegate Units.
- Priority function: Chairman can mute delegate microphones by a press of priority button.
- Detachable & Flexible 15" gooseneck microphone.
- LED Indicator on Microphone, to indicate 'Mic Active' status
- Available in elegant Black Color
- Chairman microphone press priority button.
- FIFO & LIFO: FIFO (First In First Out) & LIFO (Last In First Out) are ultra flexible & adjustable modes in which the participant enters or exits a discussion.



## MX CSM 300D (Delegate)

### Wired Delegate Microphone

- Highly flexible & customizable system supporting 260 Units.
- Supports up to 5 active units.
- Fully automatic no operator required.
- Detachable & Flexible 15" gooseneck microphone.
- LED Indicator on Microphone, to indicate 'Mic Active' status
- Available in elegant Black Color
- FIFO & LIFO: FIFO (First In First Out) & LIFO (Last In First Out) are ultra flexible & adjustable modes in which the participant enters or exits a discussion.



# CONTROLLER & VIDEO PROCESSOR FOR WIRED AUDIO CONFERENCE SYSTEM



## MX CSM 300R (Controller)

### Wired Conference Controller

- The main unit of the portable conference system can support 60 units delegate and chairman microphone and can be extended to support 250 units microphone with extension power unit
- It is equipped with four groups or 8p-DIN interface for system connecting
- It offers system support discuss mode : Free mode, FIFO mode (1-9), Limit mode 1-9 • The system working mode can display on LCD
- It offers support video camera auto-track with video processor MX CSM-300R
- **Connection :**
- 1 pcs13m main cable with 8PIN plugs
- 8 PIN socket for system connection



## MX CSM 600 (Processor)

### Wired Conference Video Processor

- Support central control system with RS232 interface.
- Support PELCO-D and VISCA communication protocol
- Control and preset camera by software or processor front panel.
- Support up to 256 preset tracking points in one system.
- RS232/RS422/RS485/USB interface for camera control.
- RS232/RJ45(DATA) /USB interface for conference main unit connection.
- RS232/RS422/RS485 interface for camera control.
- Support more cameras and more video connection interface by connecting HD Hybrid Matrix.



# WIRED SHORTGUN / BOUNDARY CONFERENCE SYSTEM



## MX CSM 500C (Chairman)

### Wired Chairman Microphone

- Frequency Response: 40Hz-16KHz
- Sensitivity: -44 dB:2dB
- Dimension: 130x55x105(mm)
- Installation Dimension: 105x40(mm)
- Length Of Gooseneck: 280mm
- Support Discuss And Video
- Chairman With Priority Button



## MX CSM 400C (Chairman)

### Wired Chairman Microphone

- Frequency response: 40Hz-16kHz
- Sensitivity: -44 dB+2dB
- Dimension: 69x87x18(mm)
- Support discuss and video
- Chairman with priority button

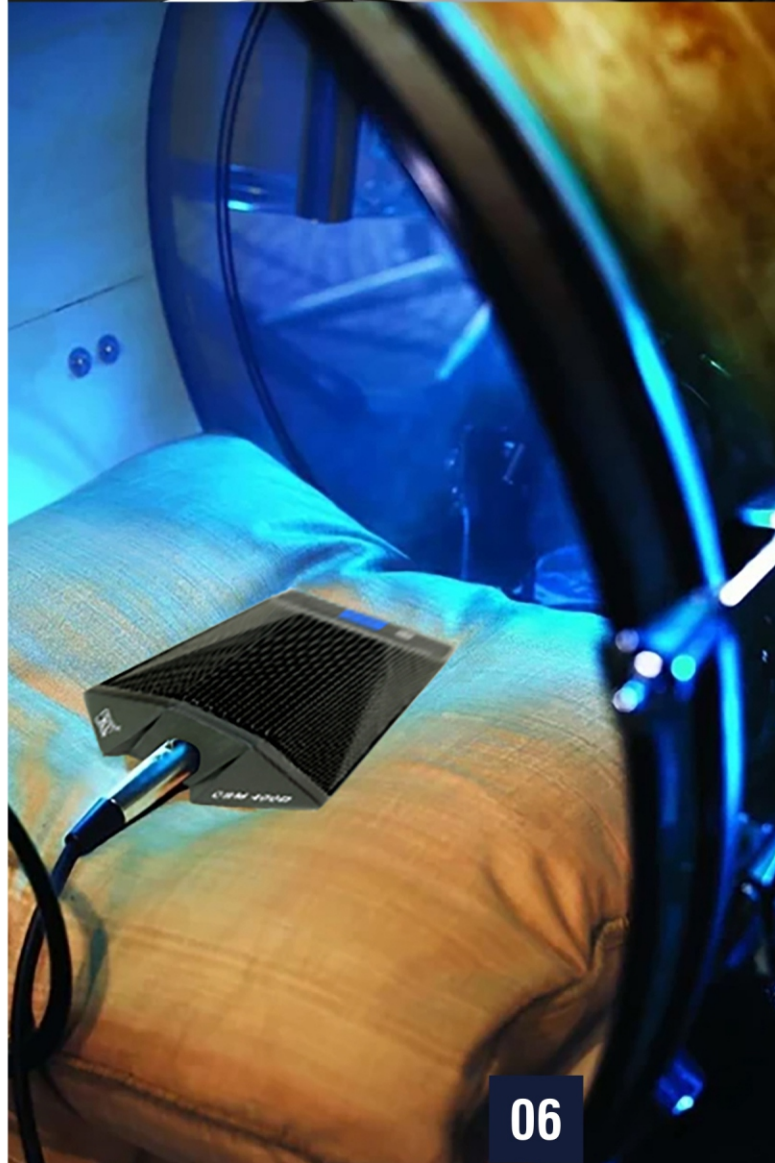

# FEEDBACK SUPPRESSOR FOR CONFERENCE MICROPHONE



## MX CSM 400F

### Wired Chairman Microphone

- Independent microphone and line input switch EFX port support connecting to conference system
- Frequency shift : 7Hz±1Hz
- Input impedance : ≥5KΩ
- Output impedance : ≤600Ω
- Microphone Gain : 5~14dB
- Frequency response : 20Hz-20 KHz in frequency non-shift state  
100Hz-15 KHz in frequency shift state
- MX CSM 400F support LCD display system status

# HD VIDEO MATRIX 4x4



## MX 9600MS

### Matrix

- Input : 4 channel HDMI
- Input connector : Type A 19 Pin Male
- Input resolution : MAX 4K@30Hz RGB4:4:4, YCbCr4:4:4, YCbCr4:2:2
- Output : 4 channel HDMI
- Output connector : Type A 19 Pin Female
- Output resolution : MAX 4K@30Hz RGB4:4:4, YCbCr4:4:4, YCbCr4:2:2
- HDMI standard : HDMI1.4
- HDMI Inbuilt audio : PCM
- Control port : (2) RS232 (1) Rj45
- Port connector : (1),DB9 RS232 Input female connector,  
(1) DB9 RS232 output male connector,  
(1) RJ45 232 output
- Button : White button, Support for switching, scene calling



# EXTENSION UNIT FOR WIRED CONFERENCE SYSTEM



## MX CSM 300E

### Extension Unit for Wired Conference System

- **AC POWER SOCKET:** Power 230VAC 50/60Hz , FUSE 8A
- **EXPANDER OUTPUT:** 6 inputs for Chairman/Delegate units. Each line can be connected to up to 30 units (do not connect more than 30). One extension power unit can manage up to 60 units.
- **In-line Power Switches:** After connecting the microphones to the system, set the switches of the lines involved on the "I" position. The LED light will indicate that the line is powered.
- **EXPANDER LINK IN:** Connect this input to one of the 4 controller outputs using the cable Provided
- **EXPANDER LINK OUT:** Connect this output to the next expansion unit input using the provided cable There is no limit to the number of expansion units that can be connected, yet the total number of manageable microphone units must not exceed 254.

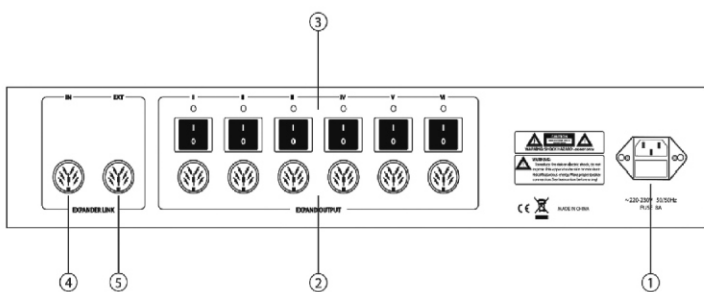

# DISCUSSION AUDIO CONFERENCE SYSTEM



## MX CSM 250C / 250D

### Discussion Conference Microphone



## MX CSM 7000R

### Discussion Conference Controller

- Designed for simple conference discussion.
- Main unit can support 60 microphone units, it could be extend to support 250 units with extension power unit.
- Three group 8P-DIN outlets interface for system connection.
- Frequency response : 40Hz-16KHz
- Sensitivity: -40dB ± 2dB
- Dimension: 153x 135x58mm
- Length of gooseneck: 390mm (fixed)
- N.W: 0.5kg
- Support discuss
- Chairman with priority button
- Microphone equipped with 1.5-meter 8P-DIN cable



# RETRACTABLE AUDIO CONFERENCE SYSTEM AND CONTROLLER



**MX X1-3C / MX X1-3D**

## Retractable Conference Microphone

- A hidden heart-shaped capacitive interface microphone, made of high-quality brass, with a built-in shock pad and an RF filter. Its uniqueness is that the interior is designed according to the principle of mechanical expansion.
- With the automatic shutdown function, the microphone will be automatically shut down for 45 seconds without the pickup state (when the sound within the pickup range is lower than 50dB)
- Ultra-low section
- The microphone can be hidden when not in use
- Built-in RF filter
- Unique touch switch design, the microphone can only be turn ON when bounced
- Sound pick-up method : Reflect back from the table
- Sound pick-up distance : 30-60 cm
- Anti-mobile phone, high-frequency interference
- Support camera video tracking function
- Power supply by conference controller, the input voltage of 18V is in the safe range
- Connected by CAT6 cable via the PCB box under the table
- Frequency response (Hz) : 20Hz-20KHz
- Directive property: super cardioid
- Output impedance (ohm) : 75Ω
- Sensitivity : -36dB±2dB
- S.N.R : 85dB 1KHz at 1 Pa
- Dynamic range : 140dB, 1KHz at max SPL
- Maximum sound pressure : 149dB SPL 1KHz THD1%
- N.W. : 0.15 kg
- Indicate : LED light(red)
- Material : High quality brass

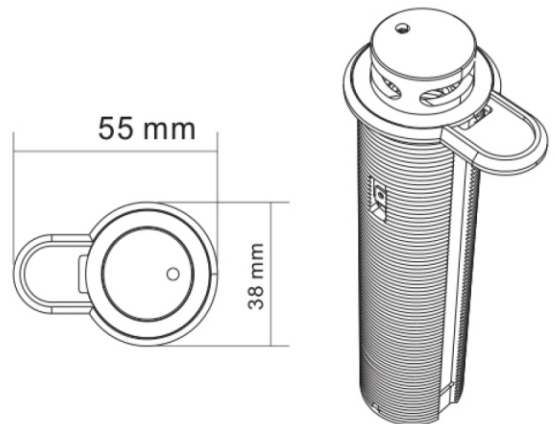
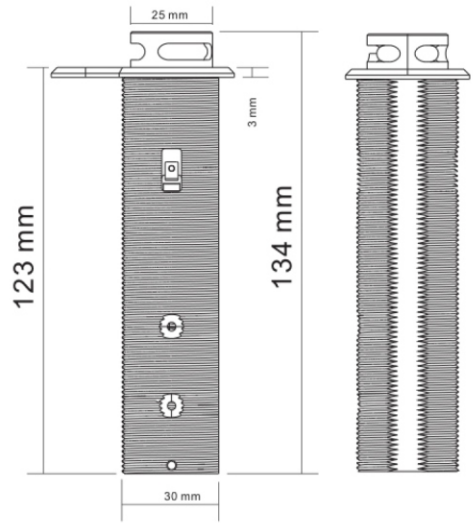

# DIGITAL CONFERENCE CONTROLLER



## MX CSM 950M

### Digital Conference Controller

- A sampling frequency of 48kHz is supported by the system.
- In order to ensure a clear, highly sensitive, and perfect sound quality, CMU built-in high-performance dual-core CPU, 32 bit high-speed DSP technologies, feedback suppression, noise cancellation, automatic gain, and digital equalization are all available.
- TCP (transmission control protocol) and IP (internet protocol) are all available, enabling a reliable and safe management.
- Built-in video tracking control and ballot processor, high definition switching matrix are available for auto video tracking with HD video matrix.
- The CMU owns a built-in USB, allowing the realizing of recording and monitoring.
- Audio could be outputted in balanced or unbalanced way.
- Different kinds of interfaces, like, Ethernet, RS422 and RS232, could meet requirements towards different devices.
- Three modes are available, including REQUEST(1-4),LIMIT (1-4), and FIFO (1-4). They all support speech timing function.
- Multiple conference functions could be realized when CMU is connected to computer.
- Power Input: 220-240V,AC 50/60Hz
- Static Power: 12W
- Maximum Output Power: 350W
- Frequency Response: 20Hz-20KHz
- S/N: > 80dB
- T.H.D: <0.05%
- Dimensions: 484x 88 x 360 mm, 2 U rack 19"



# NETWORK DIGITAL CONFERENCE SYSTEM



**MX 611C / 611D**

## Network Digital Conference Microphone



**MX 600HD**

## Network Digital Conference Controller

- The Conference Main Unit forms the core of the entire conference system. It provides power supply to all contribution unit and serves as key component to link system hardware to software control. The CMU adopt DSP techniques such as feedback suppression, noise cancellation, automatic gain, and digital equalization. It's flexible and reliable for any conference of mini/medium/large meeting.
- In order to ensure a clear, highly sensitive, and perfect sound quality, CMU built-in high-performance dual-core CPU, 32 bit high-speed DSP technologies, feedback suppression, noise cancellation, automatic gain, and digital equalization are all available.
- Built-in video tracking control and ballot processor, high definition switching matrix are available for auto video tracking with video matrix.
- The CMU owns a built-in USB, allowing the realizing of recording and monitoring.
- Different kinds of interfaces, like, Ethernet, RS422 and RS232, could meet requirements towards different devices.
- Three modes are available, including REQUEST(1-9),LIMIT (1-9), and FIFO (1-9). They all support speech timing functions.
- Power Input : 230VAC 50/60Hz
- Maximum Output Power : 350W
- Frequency Response : 100Hz-15KHz

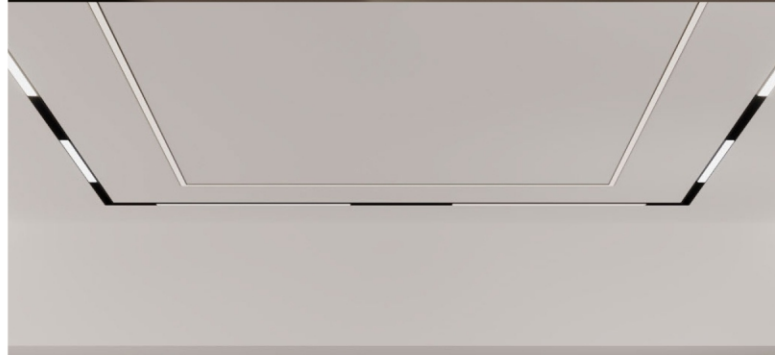

# IR CLASSROOM MICROPHONE SOLUTION



## MX IRCL CU

### IR Classroom Microphone Solution

- With dual channel function, for student and teacher using.
- Up to 4 infrared receiver can be connected to ensure that there is no dead sound corner in the classroom.
- Volume adjust knob.
- LCD screen showing the system working status.

Load frequently : 2MHz-5MHz  
 Channel groups : 2 channel  
 Receiving sensitivity : -100dBm  
 Frequency response : 100Hz-12kHz

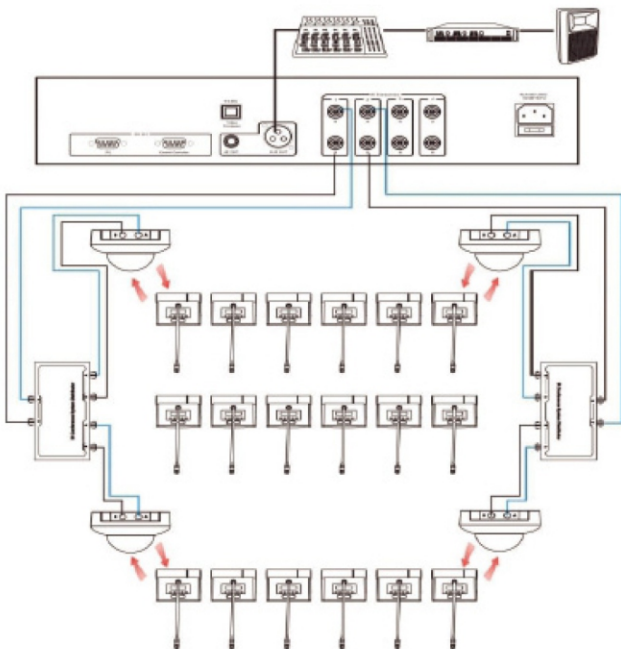

## BES3.5

### 3.5" TWO-WAY MONITOR SPEAKER

BES Series: Perfect for Personal Studios and Versatile Audio Applications!

#### Description

The BES series is Superlux's latest offering designed specifically for personal studios and multi-purpose audio applications, available in two options: 3.5-inch and 5-inch models.

The BES3.5 is a 3.5-inch two-way monitor system that includes one active and one passive speaker, combining high-accuracy sound quality with flexible connectivity options. Ideal for music production, its sleek design and durable construction make it a reliable choice for various environments.

#### Features

- 3.5" Woofer and 1" Tweeter: Delivers powerful, deep bass and crisp, clear highs, ensuring a balanced sound across the entire frequency range.
- 50-Watt Output Power: Perfectly suited for various audio needs, ideal for both desktop and near-field monitoring environments.
- Rear Volume control: Convenient for users to quickly adjust volume, enhancing ease of use and overall experience.



#### Specifications

Crossover Frequency	3 KHz
Max. SPL	100 dB SPL
Frequency Response (-3 dB)	80 - 20 KHz
Impedance	10k Ω
LF	3.5 in.
HF	1 in. Cloth Diaphragm
Enclosure Material	Wood
Input Impedance	Bal: 1/4" TRS Unbal: RCA 1/8" Stereo
TRIM for HF	+3 dB / -3 dB
TRIM for LF	+3 dB / -3 dB
Output Power	50W

## BES5

### 5" TWO-WAY MONITOR SPEAKER

BES Series: Perfect for Personal Studios and Versatile Audio Applications!

#### Description

The BES5 is a 5-inch two-way monitor system that includes one active and one passive speaker, combining high-accuracy sound quality with flexible connectivity options. Its sleek design and durable construction make it a reliable choice for various environments. Additionally, it features high and low-frequency gain and attenuation controls to better adapt to different room environments and speaker placements.

#### Features

- 5" Woofer and 1" Tweeter: Delivers powerful, deep bass and crisp, clear highs, ensuring a balanced sound across the entire frequency range.
- 100-Watt Output Power: Perfectly suited for various audio needs, ideal for both desktop and near-field monitoring environments.
- Rear Volume control: Convenient for users to quickly adjust volume, enhancing ease of use and overall experience.



#### Specifications

Crossover Frequency	3 KHz
Max. SPL	105 dB SPL
Frequency Response (-3 dB)	60 - 20 KHz
Impedance	10k Ω
LF	5 in.
HF	1 in. Cloth Diaphragm
Enclosure Material	Wood
Input Impedance	Bal: 1/4" TRS Unbal: RCA 1/8" Stereo
TRIM for HF	+3 dB / -3 dB
TRIM for LF	+3 dB / -3 dB
Output Power	100W

# HMD660PRO

PROFESSIONAL HEADSET WITH INCORPORATED DYNAMIC MIC

## Description

HMD660PRO series are closed-back dynamic headsets designed for live broadcasts, DJ's, video conferences, gaming, and multimedia applications. With its tailored frequency response and extremely detailed studio-grade quality driver, HMD660PRO truly delivers the voice of instruments and vocals and the penetration in live environment. HMD660PRO provides precise accuracy and well-balanced sound profile, flatter and wider frequency response and lower distortion.



## Features

- Dynamic closed back headset.
- Closed-back headphones for optimum ambient noise attenuation.
- Integrated professional dynamic microphone with supercardioid polar pattern to give excellent speech intelligibility.
- Soft velvet earpads ensure listening comfort and fit after long time use.



Headphone Specifications	
Type	Dynamic, closed-back, over-ear
Sensitivity	96 dB SPL (1mW)
Frequency Response	10 – 30,000 Hz
Max. Input Power	100 mW
Rated Impedance	32 Ω & 150 Ω
Clamping Force	approx. 5N
Cables	2-meter straight cable

Microphone Specifications	
Type	Dynamic Microphone
Polar Pattern	SuperCardioid
Frequency Response	60-17,000 Hz
Sensitivity	-59 dBV/pa
Impedance	500 Ω
Equivalent Noise Level	15 dB
Max. SPL	130 dB
Finish	Black
Connector	3.5 mm TRRS

Included  Carrying pouch  Headworn Mic Foam  MIC, HP: 3.5 mm (1/8") TRRS

# HD668BMKII

PROFESSIONAL STUDIO STANDARD HEADPHONES

## Description



The HD668B has been a classic in online forums for 15 years, earning the title of "King of Balanced and Authentic Sound." Building on this, Superlux introduces the HD668BMKII, which retains the classic design while adding innovative features for an enhanced listening experience. With a new diaphragm material, the HD668BMKII significantly improves sound resolution, delivering richer, more detailed audio. It maintains a neutral, balanced tuning with clear mids, smooth highs, and strong bass that doesn't overwhelm other frequencies.

## Features

- Classic Redesign: Keeps the iconic HD668B look, adding new features.
- Enhanced Sound: New diaphragm material for improved sound clarity and detail.
- Balanced Tuning: Clear mids, bright highs, and deep bass without overpowering.
- Comfort Fit: Lightweight, redesigned for extended comfort.
- User-Friendly: Professional sound with simple, intuitive controls for any use.



Specifications	
Type	Dynamic, Semi-open
Driver	Ø50 mm, neodymium
Sensitivity	98 dB SPL (1 mW)
Frequency Response	10 – 30,000 Hz
Max. Input Power	300 mW
Rated Impedance	56 Ω (Copper-coated aluminum wire)
Ear Pads	High-quality protein PU leather earmuffs
Cables	Separate connection cable, Ø3.5×1.5 m
Connector	3.5 mm gold-plated to 6.3 mm
Caliper Pressure	Approx. 4.5 N
Net Weight (without cable)	260 g (9.17 oz)

Included  Carrying pouch  Headworn Mic Foam  MIC, HP: 3.5 mm (1/8") TRRS

# CSM 110 WIRELESS CONFERENCE SYSTEM

## RECEIVER with In-built PROCESSOR



**MX CSM 110 R (RECEIVER with In-built PROCESSOR)**



**CSM 110C**

**CSM 110D**

### Description

This advanced wireless conference system is designed for professional multi-user environments, offering seamless communication and efficient meeting management. The host supports six simultaneous wireless audio channels, allowing up to six participants to speak at the same time. The number of active speakers can be adjusted according to the needs of the meeting, and the system can register and match up to 2,000 attending units for large-scale events.

### Features

- Supports 6 simultaneous speakers with registration for up to 2000 attending units.
- 20 selectable channels to allocate frequencies and avoid wireless interference.
- Self-developed communication technology ensures stable, fast (0.5–1.25s) auto-synced connections.
- Video tracking function with support for VISCA, PELCO-P, and PELCO-D protocols.

# MX ACT 800 UHF WIRELESS MICROPHONE SYSTEM



### Description

The MX 8-Channel UHF Wireless Microphone System is a compact and reliable dual-channel setup featuring dynamic microphones with UHF transmitters and a noise-squelch receiver. Designed for clear audio without cables, it uses built-in battery-powered transmitters to send signals via radio waves to a receiver for high-quality sound.

### Features

- **Quad Variable Frequency Channels:** 8-channel design for cordless singing, karaoke, and energetic stage performances.
- **UHF Band Transmission:** Clear, noise-free, distortion-free audio with high signal-to-noise ratio.
- **Multiple Output Jacks:** 8 balanced XLR outputs for connecting to mixers, stereos, or speakers.
- **Rugged 1RU Metal Chassis:** Durable design suitable for indoor and outdoor use, including schools, churches, and professional events.

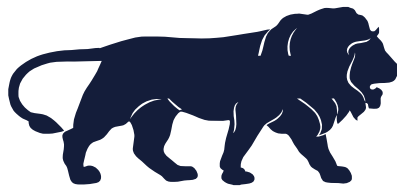

MADE IN  
**BHARAT**

## MX A130



### Description

A130 Amplifier – 200W RMS max power with 4 Mic, 2 Mic/Line, and 1 Aux input; versatile outputs for 4Ω, 8Ω, 70V, and 100V speakers; wide 50Hz–20kHz frequency response; bass/treble tone control; built-in Mp3/USB/SD/Bluetooth playback; echo and mic priority functions; full protections (over-temperature, DC, AC fuse); supports AC 220–240V or DC 24V power.

### Features

- **Power Output:** 200W RMS Max, 130W RMS 10%, 115W RMS 5%, 100W RMS 2%
- **Inputs:** 4 Mic (1mV), 2 Mic/Line (1mV/300mV), 1 Aux (150mV)
- **Outputs:** Pre-amp 300mV; 4Ω, 8Ω, 70V, 100V speaker support
- **Frequency Response:** 50Hz–20kHz (+3dB) / 50Hz–15kHz (+3dB) for 70V/80V/100V.
- **Controls & Playback:** Bass/Treble control; MP3 via USB, SD, Bluetooth
- **Special Features:** Echo on Mic1–Mic4; Mic priority function
- **Protections:** Over-temperature, DC protection, AC Fuse 4A

## MX A170



### Description

A170 Amplifier – delivers up to 240W RMS power with 4 Mic, 2 Mic/Line, and 1 Aux input; versatile outputs for 4Ω, 8Ω, 70V, and 100V speakers; wide frequency response (50Hz–20kHz); bass/treble tone control; built-in MP3/USB/SD/Bluetooth playback; echo and mic priority functions; protected against over-temperature, DC faults, and AC surges; supports AC 220–240V or DC 24V power supply.

### Features

- **Power Output:** 240W RMS Max, 170W RMS 10%, 140W RMS 5%, 120W RMS 2%
- **Input Channels:** 4 Mic (1mV), 2 Mic/Line (1mV/300mV), 1 Aux (150mV)
- **Outputs:** Pre-amp 300mV; supports 4Ω, 8Ω, 70V, 100V speakers
- **Frequency Response:** 50Hz–20kHz (+3dB) / 50Hz–15kHz (+3dB) for 70V/80V/100V
- **Controls & Playback:** Bass/Treble control; MP3 via USB, SD card, Bluetooth
- **Special Features:** Echo on Mic1–Mic4; Mic priority function
- **Protections:** Over Temperature, DC protection, AC Fuse 4A
- **Power Supply:** AC 220–240V 50/60Hz or DC 24V

## **MX MDR Technologies Ltd.**

FACTORY :

Plot No.101, Sector1 Gaurai pada, Vasai (E), Dist. Palghar-401208. INDIA

CORPORATE EXPERIENCE CENTER :

Unit No.5/K, Laxmi Industrial Estate, New Link Road, Andheri (W),  
Mumbai-400053, INDIA

☎ +91 98922 50949 ✉ [info@mdrelectronics.com](mailto:info@mdrelectronics.com)

[www.mdrelectronics.com](http://www.mdrelectronics.com)

